

September 17, 2024

Will Seuffert
Executive Secretary
Minnesota Public Utilities Commission
121 7th Place East, Suite 350
St. Paul, Minnesota 55101-2147

RE: **Reply Comments of the Minnesota Department of Commerce, Division of Energy Resources
Impacts of the “Capacity” Definition in Minn. Stat. § 216B.164 and Associated Rules on Net
Metering Eligibility for Rate-Regulated Utilities**
Docket No. E002, E111, E017, E015/CI-24-200

Dear Mr. Seuffert:

Attached are the reply comments of the Minnesota Department of Commerce, Division of Energy Resources (Department) in the following matter:

In the Matter of Impacts of the “Capacity” Definition in Minn. Stat. §
216B.164 and Associated Rules on Net Metering Eligibility for Rate-
Regulated Utilities

The Department clarifies its recommendation in the attached comments. The Department is available to answer any questions the Minnesota Public Utilities Commission may have.

Sincerely,

/s/ Dr. Sydnie Lieb
Assistant Commissioner of Regulatory Analysis

DT/ad
Attachment



Before the Minnesota Public Utilities Commission

Reply Comments of the Minnesota Department of Commerce Division of Energy Resources

Docket No. E002, E111, E017, E015/CI-24-200

I. INTRODUCTION

The Department provides the following reply comments In the Matter of Impacts of the “Capacity” Definition in Minn. Stat. § 216B.164 and Associated Rules on Net Metering Eligibility for Rate-Regulated Utilities.

In the context of net-metered rate eligibility, capacity represents the capability of an interconnected distributed energy resource (DER) system to produce, transmit, or deliver electric energy to the utility system. Nameplate rating may represent this capability, but it will not be representative in all situations. Instead, maximum export capacity represents the capability of the system to produce, transmit, or deliver electric energy to the utility system.

The Department maintains its position from initial comments that the governing statute is clear that capacity is defined at the point of interconnection with the utility system with respect to net-metered rate eligibility. The Department wishes to clarify its recommendation from initial comments to read that utilities should apply the definition of capacity for purposes of net-metered rate eligibility as the maximum export capacity of the DER system at the point of interconnection, consistent with the governing statute.

II. PROCEDURAL HISTORY

On May 22, 2024, the Commission issued its Order initiating a proceeding into the application of the definition of “capacity.”¹

On June 4, 2024, the Commission issued a Notice of Comment Period² in the present docket requesting that parties comment on the following:

How should the Commission apply the definition of “capacity” in Minn. Stat. § 216B.164 and Associated Rules without creating reliability problems related to net-metering rate eligibility for rate-regulated utilities?

¹ Order Initiating Proceeding Into Definition of “Capacity” – In the Matter of Dakota Electric’s Updates to Specific Distribution Interconnection Process and Interconnection Agreement; In the Matter of Updating the Generic Standards for the Interconnection and Operation of Distribution Generation Facilities Established Under Minn. Stat. § 216B.1611, Docket Nos. E111/M-18-711, E999/CI-16-521 (May 24, 2024). (eDocket No. [20245-207026-02](#)). Hereinafter “May 22, 2024 Order.”

² Notice of Comment Period - In the Matter of Impacts of the “Capacity” Definition in Minn. Stat. § 216B.164 and Associated Rules on Net Metering Eligibility for Rate-Regulated Utilities, Docket No. E002, E111, E017, E015/CI-24-200 (June 4, 2024). (eDocket No. [20246-207384-01](#)). Hereinafter “Notice.”

The Notice identified the following topics open for comments:

- How should the Commission consider the “capacity” definition in Minn. Stat. § 216B.164 and associated rules on net metering eligibility for rate-regulated utilities?
- What should the Commission consider regarding the definition of “capacity” as it relates to reliability and net metering rate eligibility?
- Are there other issues or concerns related to this matter?

On July 30, 2024, the Commission extended the comment period at the request of the Minnesota Rural Electric Association (MREA), DEA, MnSEIA, Xcel Energy, Minnesota Power, and Otter Tail Power.³

On September 3, 2024, the following parties, including the Department, submitted initial comments in this proceeding:

- Dakota Electric Association (DEA);⁴
- Minnesota Power (MP);⁵
- Minnesota Rural Electric Association (MREA);⁶
- Minnesota Solar Energy Industries Association (MnSEIA);⁷
- Nokomis Energy (Nokomis);⁸
- Northern States Power Company, dba Xcel Energy (Xcel);⁹ and,
- Otter Tail Power Company (OTP).¹⁰

³ Notice of Extended Comment Period - In the Matter of Impacts of the “Capacity” Definition in Minn. Stat. § 216B.164 and Associated Rules on Net Metering Eligibility for Rate-Regulated Utilities, Docket No. E002, E111, E017, E015/CI-24-200 (July 30, 2024). (eDocket No. [20247-209118-01](#)).

⁴ Comments, Dakota Electric Association, In the Matter of Impacts of the “Capacity” Definition in Minn. Stat. § 216B.164 and Associated Rules on Net Metering Eligibility for Rate-Regulated Utilities, Docket No. E002, E111, E017, E015/CI-24-200 (September 3, 2024). (eDocket No. [20249-209935](#)). Hereinafter “DEA Comments.”

⁵ Comments, Minnesota Power, In the Matter of Impacts of the “Capacity” Definition in Minn. Stat. § 216B.164 and Associated Rules on Net Metering Eligibility for Rate-Regulated Utilities, Docket No. E002, E111, E017, E015/CI-24-200 (September 3, 2024). (eDocket No. [20249-209946-01](#)). Hereinafter “MP Comments.”

⁶ Comments, Minnesota Rural Electric Association, In the Matter of Impacts of the “Capacity” Definition in Minn. Stat. § 216B.164 and Associated Rules on Net Metering Eligibility for Rate-Regulated Utilities, Docket No. E002, E111, E017, E015/CI-24-200 (September 3, 2024). (eDocket No. [20249-209951-01](#)). Hereinafter “MREA Comments.”

⁷ Comments, Minnesota Solar Energy Industries Association, In the Matter of Impacts of the “Capacity” Definition in Minn. Stat. § 216B.164 and Associated Rules on Net Metering Eligibility for Rate-Regulated Utilities, Docket No. E002, E111, E017, E015/CI-24-200 (September 3, 2024). (eDocket No. [20249-209948-01](#)). Hereinafter “MnSEIA Comments.”

⁸ Comments, Nokomis Energy, In the Matter of Impacts of the “Capacity” Definition in Minn. Stat. § 216B.164 and Associated Rules on Net Metering Eligibility for Rate-Regulated Utilities, Docket No. E002, E111, E017, E015/CI-24-200 (September 3, 2024). (eDocket No. [20249-209950-01](#)). Hereinafter “Nokomis Comments.”

⁹ Comments, Northern States Power Company, dba Xcel Energy, In the Matter of Impacts of the “Capacity” Definition in Minn. Stat. § 216B.164 and Associated Rules on Net Metering Eligibility for Rate-Regulated Utilities, Docket No. E002, E111, E017, E015/CI-24-200 (September 3, 2024). (eDocket No. [20249-209949-01](#)). Hereinafter “Xcel Comments.”

¹⁰ Comments, Otter Tail Power Company, In the Matter of Impacts of the “Capacity” Definition in Minn. Stat. § 216B.164 and Associated Rules on Net Metering Eligibility for Rate-Regulated Utilities, Docket No. E002, E111, E017, E015/CI-24-200 (September 3, 2024). (eDocket No. [20249-209944-01](#)). Hereinafter “OTP Comments.”

III. DEPARTMENT ANALYSIS

The Department appreciates the opportunity to further comment on the notice topics put forth by the Commission and provides its comments in response to select topics addressed by parties in reply comments. The Department observes three interrelated areas of discussion throughout the initial comments submitted by multiple parties. First, parties raised the issue of the location at which the definition of capacity applies, namely the distinction between the point of DER connection (PoC) and the point of common coupling (PCC).¹¹ Second, parties raised concerns with the inclusion of customer load in defining capacity as its variability causes the energy exported to the utility system to fluctuate.¹² Third, parties emphasized the need for a fixed value to determine net-metered rate eligibility.¹³

A. *THE LOCATION TO APPLY THE CAPACITY DEFINITION*

The distinction raised by parties between the PoC and PCC is important to the discussion of the definition of capacity. The location at which the definition of capacity applies is particularly relevant to the discussion of the impact of customer load upon energy exported to the utility system. However, the distinction between PoC and PCC is somewhat muddled by the varying language used across Minn. Stat. § 216B.164, Minn. R. 7835, MN DIP, and stated industry practice.

Minn. Stat. § 216B.164, Subd. 2a(c) defines capacity “at the point of interconnection.”¹⁴ In the rules promulgating Minn. Stat. § 216B.164, Minn. R. 7835.0100, Subp. 4 defines capacity “at the point of common coupling,”¹⁵ which is further defined as “the point where the qualifying facility’s generation system, including the point of generator output, is connected to the utility’s electric power grid.”¹⁶ Taken together, the “point of interconnection” appears to be synonymous with the “point of common coupling” for purposes of net-metered rate eligibility.

MN DIP provides additional language for the “point of DER Connection” (PoC), in which PoC is defined as “the point where an individual DER is electrically connected in a Local EPS [Electric Power System] and meets the requirements of this standard exclusive of any load present in the respective part of the Local EPS.”¹⁷ Meanwhile, MN DIP defines PCC as “the point where the Interconnection Facilities connect with the Area EPS Operator’s Distribution System.”¹⁸ In the context of MN DIP, the PoC is distinct from the PCC. A key element of the distinction between the PoC and PCC is customer load,

¹¹ DEA Comments at 6, MP Comments at 2, OTP Comments at 2, Nokomis Comments at 2, MnSEIA Comments at 4, Xcel Comments at 3.

¹² DEA Comments at 9-10, MP Comments at 3-4, OTP Comments at 7, MREA Comments at 5-6, 8.

¹³ DEA Comments at 5, 11; MP Comments at 3-4, OTP Comments at 7, MREA Comments at 8.

¹⁴ [Minn. Stat. § 216B.164, Subd. 2a\(c\)](#)

¹⁵ [Minn. R. 7835.0100, Subp. 4](#)

¹⁶ [Minn. R. 7835.0100, Subp. 17a](#)

¹⁷ [MN DIP Glossary of Terms at 5.](#)

¹⁸ [MN DIP Glossary of Terms at 4.](#)

namely that PoC is exclusive of customer load while the PCC is inclusive of load. The Department provides Figure 1 below, a portion of the figure presented in MN DIP to depict the relationship of the terms:

Department Figure 1: Point of DER Connection (PoC) and Point of Common Coupling (PCC)¹⁹

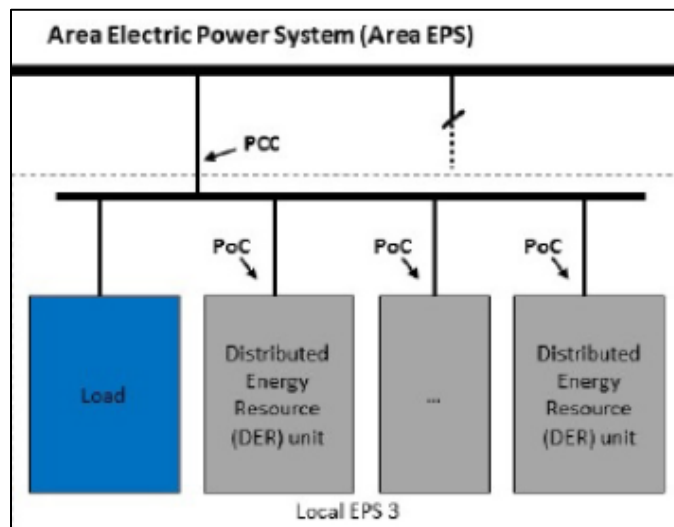

The language around the point at which the definition of capacity applies is further confounded by stated industry practice. Multiple parties stated in comments that the industry understands “point of interconnection” to be synonymous with “point of DER connection.”²⁰ This understanding creates a conflict with the terminology of the net-metered statute and associated rules, in which PCC is used rather than PoC. DEA proposes a resolution to this conflict in stating “the Commission likely understood the ‘point of common coupling’ (PCC) to be what is now referred to as the ‘point of DER connection’ (PoC) under the MN DIP.”²¹ The Commission may wish to clarify whether DEA’s understanding is accurate, as DEA’s understanding as stated would indicate that the current language of PCC in the rules associated with net-metering is not consistent with the definition of PCC used in MN DIP.

B. CUSTOMER LOAD AND EXPORT CAPACITY

The location at which the definition of capacity applies is relevant to the consideration of customer load. The inherent variability of customer load impacts the amount of energy exported to the utility system at the PCC. Multiple parties raised concerns with the inclusion of customer load in determining capacity for purposes of net-metered rate eligibility due to the impractical outcome and administrative challenges of determining eligibility based on an ever-changing value.²² The Department agrees that a

¹⁹ MN DIP Figure 1, Glossary of Terms at 4.

²⁰ DEA Comments at 6, MP Comments at 2, OTP comments at 2.

²¹ DEA comments at 9.

²² DEA Comments at 5, 9-10; MP Comments at 3, OTP Comments at 7, MREA Comments at 8.

variable capacity would be impractical to determine eligibility and would be an absurd outcome. Determination of eligibility requires a fixed value for capacity.

The Department observes, however, that this concern may arise from different interpretations among parties of export capacity. Utilities appear to interpret MnSEIA's position as export capacity at the PCC on a variable basis with fluctuations in customer load.²³ In the Department's review of MnSEIA's comments filed in this proceeding, it is not clear that fluctuations in customer load are relevant to MnSEIA's position regarding the definition of capacity for purposes of net-metered rate eligibility. However, the Department notes that multiple parties, including utilities and MnSEIA, discussed their participation in an *ad hoc* workgroup to understand issues of disagreement pertaining to this proceeding and representations made during those discussions may have informed party comments.²⁴ The workgroup meetings are not part of the formal record, and the Department was not a participant in the workgroup—and so relies on the comments submitted by parties.

The Department offers that it is helpful to differentiate between the maximum export capacity and the amount of energy exported to the utility's system at a moment in time. While the amount of energy exported may fluctuate, the capacity, or the maximum capability to do so remains fixed. Fluctuations in customer load should not factor into net-metering eligibility. In essence, when customer load is zero, the DER system would be at its maximum export capacity, as there is no customer load to offset the DER system production. Thus, customer load does not impact the maximum export capacity, and the maximum export capacity of the system would be the same regardless of the point of measurement, whether at the PoC or the PCC. Customer load and its fluctuations impact the amount of energy exported to the utility's system at any moment in time. In turn, the cumulative amount of energy exported, the net input to the utility system, determines the compensation received by the system owner.

The definition of capacity in Minn. R. 7835.0100, Subp. 4 states: "'Capacity' means the capability to produce, transmit, or deliver electric energy, and is measured by the number of megawatts alternating current at the point of common coupling between a qualifying facility and a utility's electric system."²⁵ The "capability to produce, transmit, or deliver electric energy" can be reasonably understood to refer to a maximum threshold, consistent with the need for a fixed value to determine eligibility. This maximum capability, however, will not be achieved at all times. Just as solar panels are capable of producing a maximum amount of energy yet will often be producing less than that maximum, the energy exported to the utility system will often be less than the maximum.

The capacity of a DER system is its capability to produce, transmit, or deliver electric energy to the utility system. Multiple parties indicated the use of nameplate rating as the only appropriate method

²³ DEA Comments at 5, MP Comments at 3, OTP Comments at 7.

²⁴ OTP Comments at 1, MnSEIA Comments at 6, Nokomis Comments at 2, DEA Comments at 3, Xcel Comments at 2.

²⁵ [Minn. R. 7835.0100, Subp. 4](#)

to define capacity.²⁶ Particular emphasis was placed on nameplate rating as a means of determining production capability at a fixed value.

Nameplate rating will often represent the maximum capability of a DER system, but there are cases in which the nameplate rating will diverge from the maximum. Inverter settings can be adjusted to de-rate the device, setting the maximum operating threshold at a fixed value below that of the nameplate rating. In addition, power control limiting can establish DER capacity below that of nameplate capacity, as defined in MN DIP 5.14.3 and described in further detail in the Technical Interconnection and Interoperability Requirements (TIIR) section 11.²⁷ Such instances of limiting the capability of a DER system “to produce, transmit, or deliver electric energy” are relevant to the application of the definition of capacity.

DEA discusses the use of power control limiting, using a Power Control System (PCS), “to establish an export capacity different than its nameplate capacity.”²⁸ DEA notes that export capacity is limited by adjusting the output of the DER based on the measurement of the current load on the local system. DEA also notes concerns regarding reliability impacts due to the time delay for the PCS to adjust DER output and the potential for PCS failure.²⁹ MN DIP and the TIIR provide for the use of a PCS, permitting their use and granting utilities the discretion to ensure safety and reliability concerns are sufficiently addressed prior to interconnection. If the proposed operation of a DER system using a PCS satisfies utility concerns and the operator and utility complete an interconnection agreement, then the limited export capacity, below that of nameplate capacity, should determine net-metered rate eligibility, as well. If the use of a PCS can never fully address the reliability concerns raised by utilities, then further updates to MN DIP and the TIIR may be needed.

C. THE TREATMENT OF STORAGE SYSTEMS

The treatment of solar and storage applications for purposes of net-metered rate eligibility remains on the periphery of the initial comments submitted by parties in this proceeding. OTP, DEA, and Xcel noted that the topic was discussed as part of the *ad hoc* workgroup but consensus regarding its treatment was not reached.³⁰ Both Xcel and DEA noted the Commission’s April 15, 2024 Order in Docket No. E999/CI-16-521 directed the Distributed Generation Workgroup (DGWG) to explore issues related to battery storage systems and evaluation under MN DIP:

The Commission directs the DGWG to explore if and how battery storage systems should be evaluated under the MN DIP. Topics to discuss would include: should the battery storage and DER generation be studied on a combined basis in the interconnection process, and whether or not net-

²⁶ DEA Comments at 11, OTP Comments at 8, MP Comments at 4, MREA Comments at 2.

²⁷ [MN DIP 5.14.3 at 29-30](#), [TIIR Section 11 at 35](#).

²⁸ DEA Comments at 14.

²⁹ DEA Comments at 15.

³⁰ DEA Comments at 3, OTP Comments at 1, Xcel Comments at 2.

metered DER plus storage applications should be treated differently under the MN DIP than non-exporting DER plus storage applications.³¹

The Commission's directive to the DGWG is in the context of the interconnection docket and, accordingly, focused on the interconnection process rather than net-metered rate eligibility. As such, it is not clear to the Department that the DGWG directive would fully address the issues in question in the current proceeding. The Commission may wish to clarify whether the directive to the DGWG is intended to encompass the treatment of battery storage systems for purposes of net-metered rate eligibility.

Insofar as the current proceeding remains the appropriate venue, the previous discussion of the "capability to produce, transmit, or deliver electric energy"³² is relevant to the treatment of battery storage systems for purposes of net-metered rate eligibility. The potential distinction in treatment of exporting and non-exporting battery systems appears to have been a topic of discussion in the *ad hoc* workgroup, as noted by OTP,³³ DEA,³⁴ and MnSEIA.³⁵ Ultimately, it is the maximum export capacity of the system that is determinative of the net-metered rate eligibility, as this represents the system's capability to produce, transmit, or deliver electric energy to the utility system. Broadly speaking, battery storage paired with solar placed behind an inverter, it is the maximum export capacity of the combined system—not the aggregate nameplate capacity of the system components—that should be utilized to determine net-metered rate eligibility.

The maximum export capacity of a combined solar and battery storage system may be below the aggregate nameplate capacity of the components of the combined system. Therefore, capacity for purposes of net-metered rate eligibility may be distinct from the capacity considered for interconnection under MN DIP. This distinction between capacity in different contexts would not alter the current process established in MN DIP and create reliability risks, as the definition of capacity as it applies to the interconnection process laid out in MN DIP would control in that context. Utilities would review the interconnection application and address the safe and reliable interconnection of the proposed system per the process provided in MN DIP, and nothing about the capacity of the system for purposes of net-metered rate eligibility would alter that process.

Accordingly, the Department notes that this proceeding is focused on the application of the definition of capacity without creating reliability problems, as stated in the Notice. Applying the definition of

³¹ *Order Establishing a Two-Queue System, Directing Further Discussions, and Addressing Miscellaneous Matters – In the Matter of Updating the Generic Standards for the Interconnection and Operation of Distribution Generation Facilities Established Under Minn. Stat. § 216B.1611, Docket No. E999/CI-16-521 (April 15, 2024).* (eDocket No. [20244-205355-01](#)). Order Point 7.

³² [Minn. R. 7835.0100, Subp. 4](#)

³³ OTP comments at 1.

³⁴ DEA comments at 3.

³⁵ MnSEIA comments at 7.

capacity consistent with the language of Minn. Stat. § 216B.164 and associated rules should not present reliability risks beyond those already addressed in the interconnection process.

The Department maintains its position from initial comments that the governing statute is clear that capacity is defined at the point of interconnection with the utility system with respect to net-metered rate eligibility. The Department wishes to clarify its recommendation from initial comments to read that utilities should apply the definition of capacity for purposes of net-metered rate eligibility as the maximum export capacity of the DER system at the point of interconnection, consistent with the governing statute.

IV. CONCLUSION AND RECOMMENDATION

The Department appreciates the opportunity to provide additional comments for Commission consideration in this matter. The Department maintains its position from initial comments that the governing statute is clear that capacity is defined at the point of interconnection with the utility system with respect to net-metered rate eligibility. The Department wishes to clarify its recommendation from initial comments to read that utilities should apply the definition of capacity for purposes of net-metered rate eligibility as the maximum export capacity of the DER system at the point of interconnection, consistent with the governing statute.

CERTIFICATE OF SERVICE

I, Sharon Ferguson, hereby certify that I have this day, served copies of the following document on the attached list of persons by electronic filing, certified mail, e-mail, or by depositing a true and correct copy thereof properly enveloped with postage paid in the United States Mail at St. Paul, Minnesota.

**Minnesota Department of Commerce
Reply Comments**

Docket No. E002, E111, E017, E015/CI-24-200

Dated this **17th** day of **September 2024**

/s/Sharon Ferguson

First Name	Last Name	Email	Company Name	Address	Delivery Method	View Trade Secret	Service List Name
Ross	Abbey	ross.abbey@us-solar.com	United States Solar Corp.	100 North 6th St Ste 222C Minneapolis, MN 55403	Electronic Service	No	OFF_SL_24-200_Official
Michael	Allen	michael.allen@allenergysolar.com	All Energy Solar	721 W 26th st Suite 211 Minneapolis, MN 55405	Electronic Service	No	OFF_SL_24-200_Official
Brian	Allen	brian.allen@allenergysolar.com	All Energy Solar, Inc	1642 Carroll Ave Saint Paul, MN 55104	Electronic Service	No	OFF_SL_24-200_Official
David	Amster Olzweski	david@mysunshare.com	SunShare, LLC	1151 Bannock St Denver, CO 80204-8020	Electronic Service	No	OFF_SL_24-200_Official
Jay	Anderson	jaya@cmpas.org	CMPAS	7550 Corporate Way Suite 100 Eden Prairie, MN 55344	Electronic Service	No	OFF_SL_24-200_Official
Janet	Anderson	jcainstp@icloud.com	-	1799 Sargent St. Paul, MN 55105	Electronic Service	No	OFF_SL_24-200_Official
Christine	Andrews	christineandrewsjd@gmail.com		792 Goodrich Ave St Paul, MN 55105	Electronic Service	No	OFF_SL_24-200_Official
John	Bailey	bailey@ilsr.org	Institute For Local Self-Reliance	1313 5th St SE Ste 303 Minneapolis, MN 55414	Electronic Service	No	OFF_SL_24-200_Official
Mark	Bakk	mbakk@lcp.coop	Lake Country Power	26039 Bear Ridge Drive Cohasset, MN 55721	Electronic Service	No	OFF_SL_24-200_Official
Laura	Beaton	beaton@smwlaw.com	Shute, Mihaly & Weinberger LLP	396 Hayes Street San Francisco, CA 94102	Electronic Service	No	OFF_SL_24-200_Official

First Name	Last Name	Email	Company Name	Address	Delivery Method	View Trade Secret	Service List Name
Jeff	Benson	jbenson@southcentralelect ric.com	South Central Electric Association	PO Box 150 71176 Tiell Drive St. James, MN 56081	Electronic Service	No	OFF_SL_24-200_Official
Derek	Bertsch	derek.bertsch@mrenergy.c om	Missouri River Energy Services	3724 West Avera Drive PO Box 88920 Sioux Falls, SD 57109-8920	Electronic Service	No	OFF_SL_24-200_Official
Barb	Bischoff	barb.bischoff@nngco.com	Northern Natural Gas Co.	CORP HQ, 714 1111 So. 103rd Street Omaha, NE 681241000	Electronic Service	No	OFF_SL_24-200_Official
William	Black	bblack@mmua.org	MMUA	Suite 200 3131 Fernbrook Lane North Plymouth, MN 55447	Electronic Service	No	OFF_SL_24-200_Official
Kenneth	Bradley	kbradley1965@gmail.com		2837 Emerson Ave S Apt CW112 Minneapolis, MN 55408	Electronic Service	No	OFF_SL_24-200_Official
Jon	Brekke	jbrekke@grenergy.com	Great River Energy	12300 Elm Creek Boulevard Maple Grove, MN 553694718	Electronic Service	No	OFF_SL_24-200_Official
Kathleen	Brennan	kbrennan@spencerfane.co m	Spencer Fane LLP	100 South Fifth Street, Suite 2500 Minneapolis, MN 55402	Electronic Service	No	OFF_SL_24-200_Official
Mark B.	Bring	mbring@otpc.com	Otter Tail Power Company	215 South Cascade Street PO Box 496 Fergus Falls, MN 565380496	Electronic Service	No	OFF_SL_24-200_Official
Christopher	Browning	christopher.browning@next eraenergy.com		N/A	Electronic Service	No	OFF_SL_24-200_Official
Christina	Brusven	cbrusven@fredlaw.com	Fredrikson Byron	60 S 6th St Ste 1500 Minneapolis, MN 55402-4400	Electronic Service	No	OFF_SL_24-200_Official

First Name	Last Name	Email	Company Name	Address	Delivery Method	View Trade Secret	Service List Name
Jessica	Burdette	jessica.burdette@state.mn.us	Department of Commerce	85 7th Place East Suite 500 St. Paul, MN 55101	Electronic Service	No	OFF_SL_24-200_Official
Jerry	Byer	jbyer@itasca-mantrap.com	Itasca-Mantrap Coop. Electric Assn.	PO Box 192 Park Rapids, MN 56470	Electronic Service	No	OFF_SL_24-200_Official
Daniel T	Carlisle	todd-wad@toddwadana.coop	Todd-Wadana Electric Cooperative	550 Ash Ave NE PO Box 431 Wadena, MN 56482	Electronic Service	No	OFF_SL_24-200_Official
Douglas M.	Carnival	dcarnival@carnivalberns.com	McGrann Shea Carnival Straughn & Lamb	N/A	Electronic Service	No	OFF_SL_24-200_Official
Pat	Carruth	pat@mnvalleyrec.com	Minnesota Valley Coop. Light & Power Assn.	501 S 1st St. PO Box 248 Montevideo, MN 56265	Electronic Service	No	OFF_SL_24-200_Official
Kenneth A.	Colburn	kcolburn@symbioticstrategies.com	Symbiotic Strategies, LLC	26 Winton Road Meredith, NH 32535413	Electronic Service	No	OFF_SL_24-200_Official
Generic Notice	Commerce Attorneys	commerce.attorneys@ag.state.mn.us	Office of the Attorney General-DOC	445 Minnesota Street Suite 1400 St. Paul, MN 55101	Electronic Service	Yes	OFF_SL_24-200_Official
Brandon	Cox	brandon.cox@magellanlp.com	Magellan Pipeline Company, L.P.	6160 Summit Dr N, Suite 205 Brooklyn Center, MN 55430	Electronic Service	No	OFF_SL_24-200_Official
Kevin	Cray	kevin@communitysolaraccess.org	CCSA	1644 Platte St Denver, CO 80202	Electronic Service	No	OFF_SL_24-200_Official
George	Crocker	gwillc@nawo.org	North American Water Office	5093 Keats Avenue Lake Elmo, MN 55042	Electronic Service	No	OFF_SL_24-200_Official

First Name	Last Name	Email	Company Name	Address	Delivery Method	View Trade Secret	Service List Name
Ross	Crutchfield	Ross.Crutchfield@magellanlp.com	Magellan Pipeline Company, L.P.	One Williams Center Tulsa, OK 74172	Electronic Service	No	OFF_SL_24-200_Official
Stacy	Dahl	sdahl@minnkota.com	Minnkota Power Cooperative, Inc.	5301 32nd Ave S Grand Forks, ND 58201	Electronic Service	No	OFF_SL_24-200_Official
Lisa	Daniels	lisadaniels@windustry.org	Windustry	201 Ridgewood Ave Minneapolis, MN 55403	Electronic Service	No	OFF_SL_24-200_Official
James	Darabi	james.darabi@solarfarm.com	Solar Farm, LLC	2355 Fairview Ave #101 St. Paul, MN 55113	Electronic Service	No	OFF_SL_24-200_Official
Danielle	DeMarre	danielle.demarre@allenergysolar.com	All Energy Solar	1264 Energy Lane St Paul, MN 55108	Electronic Service	No	OFF_SL_24-200_Official
James	Denniston	james.r.denniston@xcenergy.com	Xcel Energy Services, Inc.	414 Nicollet Mall, 401-8 Minneapolis, MN 55401	Electronic Service	No	OFF_SL_24-200_Official
Curt	Dieren	curt.dieren@dgr.com	L&O Power Cooperative	1302 S Union St Rock Rapids, IA 51246	Electronic Service	No	OFF_SL_24-200_Official
Cheryl	Dietrich	cheryl.dietrich@nexteraenergy.com	NextEra Energy Resources, LLC	700 Universe Blvd E1W/JB Juno Beach, FL 33408	Electronic Service	No	OFF_SL_24-200_Official
Kristin	Dolan	kdolan@meeker.coop	Meeker Cooperative Light & Power Assn	1725 US Hwy 12 E. Ste 100 Litchfield, MN 55355	Electronic Service	No	OFF_SL_24-200_Official

First Name	Last Name	Email	Company Name	Address	Delivery Method	View Trade Secret	Service List Name
Richard	Dornfeld	Richard.Dornfeld@ag.state.mn.us	Office of the Attorney General-DOC	Minnesota Attorney General's Office 445 Minnesota Street, Suite 1800 Saint Paul, MN 55101	Electronic Service	No	OFF_SL_24-200_Official
Steve	Downer	sdowner@mmua.org	MMUA	3025 Harbor Ln N Ste 400 Plymouth, MN 554475142	Electronic Service	No	OFF_SL_24-200_Official
Renee	Doyle	guydoyleelectric@gmail.com	Doyle Electric Inc.	PO Box 295 Amboy, MN 56010	Electronic Service	No	OFF_SL_24-200_Official
John R.	Dunlop, P.E.	JDunlop@RESMinn.com	Renewable Energy Services	Suite 300 448 Morgan Ave. S. Minneapolis, MN 554052030	Electronic Service	No	OFF_SL_24-200_Official
Kristen	Eide Tollefson	healingsystems69@gmail.com	R-CURE	28477 N Lake Ave Frontenac, MN 55026-1044	Electronic Service	No	OFF_SL_24-200_Official
R. Neal	Elliot	RNElliott@aceee.org	American Council for an Energy-Efficient Economy	ACEEE 529 14th St NW Ste 600 Washington, DC 20045	Electronic Service	No	OFF_SL_24-200_Official
Nadav	Enbar	nenbar@epri.com	EPRI	1117 Quince Ave Boulder, CO 80304	Electronic Service	No	OFF_SL_24-200_Official
Betsy	Engelking	betsy@nationalgridrenewables.com	National Grid Renewables	8400 Normandale Lake Blvd Ste 1200 Bloomington, MN 55437	Electronic Service	No	OFF_SL_24-200_Official
Oncu	Er	oncu.er@avantenergy.com	Avant Energy, Agent for MMPA	220 S. Sixth St. Ste. 1300 Minneapolis, MN 55402	Electronic Service	No	OFF_SL_24-200_Official

First Name	Last Name	Email	Company Name	Address	Delivery Method	View Trade Secret	Service List Name
John	Farrell	jfarrell@ilsr.org	Institute for Local Self-Reliance	2720 E. 22nd St Institute for Local Self-Reliance Minneapolis, MN 55406	Electronic Service	No	OFF_SL_24-200_Official
Sharon	Ferguson	sharon.ferguson@state.mn.us	Department of Commerce	85 7th Place E Ste 280 Saint Paul, MN 551012198	Electronic Service	No	OFF_SL_24-200_Official
Christine	Fox	cfox@itasca-mantrap.com	Itasca-Mantrap Coop. Electric Assn.	PO Box 192 Park Rapids, MN 56470	Electronic Service	No	OFF_SL_24-200_Official
Kornbaum	Frank	fkornbaum@mnpower.com		N/A	Electronic Service	No	OFF_SL_24-200_Official
Nathan	Franzen	nathan@nationalgridrenewables.com	Geronimo Energy, LLC	8400 Normandale Lake Blvd Ste 1200 Bloomington, MN 55437	Electronic Service	No	OFF_SL_24-200_Official
David	Freestate	dfreestate@epri.com	EPRI	942 Corridor Park Blvd Knoxville, TN 37932	Electronic Service	No	OFF_SL_24-200_Official
Katelyn	Frye	kfrye@mnpower.com	Minnesota Power	30 W Superior St Duluth, MN 558022093	Electronic Service	No	OFF_SL_24-200_Official
Hal	Galvin	halgalvin@comcast.net	Provectus Energy Development llc	1936 Kenwood Parkway Minneapolis, MN 55405	Electronic Service	No	OFF_SL_24-200_Official
Edward	Garvey	garveyed@aol.com	Residence	32 Lawton St Saint Paul, MN 55102	Electronic Service	No	OFF_SL_24-200_Official
Allen	Gleckner	gleckner@fresh-energy.org	Fresh Energy	408 St. Peter Street Ste 350 Saint Paul, MN 55102	Electronic Service	No	OFF_SL_24-200_Official

First Name	Last Name	Email	Company Name	Address	Delivery Method	View Trade Secret	Service List Name
Jenny	Glumack	jenny@mrea.org	Minnesota Rural Electric Association	11640 73rd Ave N Maple Grove, MN 55369	Electronic Service	No	OFF_SL_24-200_Official
Sarah	Groebner	sgroebner@redwoodelectr c.com	Redwood Electric Cooperative	60 Pine St Clements, MN 56224	Electronic Service	No	OFF_SL_24-200_Official
Cody	Gustafson	cgustafson@mnpower.com		N/A	Electronic Service	No	OFF_SL_24-200_Official
Tom	Guttormson	Tom.Guttormson@connexu senergy.com	Connexus Energy	14601 Ramsey Blvd Ramsey, MN 55303	Electronic Service	No	OFF_SL_24-200_Official
Natalie	Haberman	townsend@fresh- energy.org	Fresh Energy	408 St Peter St # 350 St. Paul, MN 55102	Electronic Service	No	OFF_SL_24-200_Official
James	Haler	jhaler@southcentralelectr .com	South Central Electric Association	71176 Tiell Dr P. O. Box 150 St. James, MN 56081	Electronic Service	No	OFF_SL_24-200_Official
Donald	Hanson	dfhanson@ieeee.org	Solar Photovoltaic Systems	P. O. Box 44579 Eden Prairie, MN 55344	Electronic Service	No	OFF_SL_24-200_Official
John	Harlander	john.c.harlander@xcelener gy.com	Xcel Energy	N/A	Electronic Service	No	OFF_SL_24-200_Official
Adam	Heinen	aheinen@dakotaelectric.co m	Dakota Electric Association	4300 220th St W Farmington, MN 55024	Electronic Service	No	OFF_SL_24-200_Official
Jared	Hendricks	jared.hendricks@owatonna utilities.com	Owatonna Municipal Public Utilities	PO Box 800 208 S Walnut Ave Owatonna, MN 55060-2940	Electronic Service	No	OFF_SL_24-200_Official
Annete	Henkel	mui@mutilityinvestors.org	Minnesota Utility Investors	413 Wacouta Street #230 St.Paul, MN 55101	Electronic Service	No	OFF_SL_24-200_Official

First Name	Last Name	Email	Company Name	Address	Delivery Method	View Trade Secret	Service List Name
Joe	Hoffman	ja.hoffman@smmpa.org	SMMPA	500 First Ave SW Rochester, MN 55902-3303	Electronic Service	No	OFF_SL_24-200_Official
Ronald	Horman	rhorman@redwoodelectric.com	Redwood Electric Cooperative	60 Pine Street Clements, MN 56224	Electronic Service	No	OFF_SL_24-200_Official
Lori	Hoyum	lhoyum@mnpower.com	Minnesota Power	30 West Superior Street Duluth, MN 55802	Electronic Service	No	OFF_SL_24-200_Official
Jan	Hubbard	jan.hubbard@comcast.net		7730 Mississippi Lane Brooklyn Park, MN 55444	Electronic Service	No	OFF_SL_24-200_Official
Dean	Hunter	Dean.Hunter@state.mn.us	Minnesota Department of Labor & Industry	443 Lafayette Rd N St. Paul, MN 55155-4341	Electronic Service	No	OFF_SL_24-200_Official
Casey	Jacobson	cjacobson@bepc.com	Basin Electric Power Cooperative	1717 East Interstate Avenue Bismarck, ND 58501	Electronic Service	No	OFF_SL_24-200_Official
Ralph	Jacobson	ralphj@ips-solar.com		2126 Roblyn Avenue Saint Paul, MN 55104	Electronic Service	No	OFF_SL_24-200_Official
John S.	Jaffray	jjaffray@jirpower.com	JJR Power	350 Highway 7 Suite 236 Excelsior, MN 55331	Electronic Service	No	OFF_SL_24-200_Official
Robert	Jagusch	rjagusch@mmua.org	MMUA	3025 Harbor Lane N Minneapolis, MN 55447	Electronic Service	No	OFF_SL_24-200_Official
Chris	Jarosch	chris@carrcreekelectricservice.com	Carr Creek Electric Service, LLC	209 Sommers Street North Hudson, WI 54016	Electronic Service	No	OFF_SL_24-200_Official

First Name	Last Name	Email	Company Name	Address	Delivery Method	View Trade Secret	Service List Name
Brian	Jeremiason	bjeremiason@llec.coop	Lyon-Lincoln Electric Cooperative, Inc.	205 W. Hwy. 14 Tyler, MN 56178	Electronic Service	No	OFF_SL_24-200_Official
Sarah	Johnson Phillips	sarah.phillips@stoel.com	Stoel Rives LLP	33 South Sixth Street Suite 4200 Minneapolis, MN 55402	Electronic Service	No	OFF_SL_24-200_Official
Nate	Jones	njones@hcpd.com	Heartland Consumers Power	PO Box 248 Madison, SD 57042	Electronic Service	No	OFF_SL_24-200_Official
Kevin	Joyce	kjoyce@tesla.com		N/A	Electronic Service	No	OFF_SL_24-200_Official
Mahmoud	Kabalan	mahmoud.kabalan@stthomas.edu	University of St Thomas	2115 Summit Ave. Mail OSS100 School of Engineering Saint Paul, MN 55105	Electronic Service	No	OFF_SL_24-200_Official
Camille	Kadoch	ckadoch@raponline.org	Regulatory Assistance Project	50 State Street Suite 3 Montpelier, VT 05602	Electronic Service	No	OFF_SL_24-200_Official
Ralph	Kaehler	Ralph.Kaehler@gmail.com		13700 Co. Rd. 9 Eyota, MN 55934	Electronic Service	No	OFF_SL_24-200_Official
Cliff	Kaehler	cliff.kaehler@novelenergy.biz	Novel Energy Solutions LLC	4710 Blaylock Way Inver Grove Heights, MN 55076	Electronic Service	No	OFF_SL_24-200_Official
Michael	Kampmeyer	mkampmeyer@a-e-group.com	AEG Group, LLC	260 Salem Church Road Sunfish Lake, MN 55118	Electronic Service	No	OFF_SL_24-200_Official
Jack	Kegel	jkegel@mmua.org	MMUA	3025 Harbor Lane N Suite 400 Plymouth, MN 55447-5142	Electronic Service	No	OFF_SL_24-200_Official

First Name	Last Name	Email	Company Name	Address	Delivery Method	View Trade Secret	Service List Name
Tom	Key	tkey@epri.com	EPRI	942 Corridor Park Blvd Knoxville, TN 37932	Electronic Service	No	OFF_SL_24-200_Official
Bobby	King	bking@solarunitedneighbors.org	Solar United Neighbors	3140 43rd Ave S Minneapolis, MN 55406	Paper Service	No	OFF_SL_24-200_Official
Brad	Klein	bklein@elpc.org	Environmental Law & Policy Center	35 E. Wacker Drive, Suite 1600 Suite 1600 Chicago, IL 60601	Electronic Service	No	OFF_SL_24-200_Official
Jack	Kluempke	Jack.Kluempke@state.mn.us	Department of Commerce	85 7th Place East Suite 600 St. Paul, MN 55101	Electronic Service	No	OFF_SL_24-200_Official
Steve	Kosbab	skosbab@meeker.coop	Meeker Cooperative Light and Power	1725 US Hwy 12 E Litchfield, MN 55355	Electronic Service	No	OFF_SL_24-200_Official
Michael	Krause	michaelkrause61@yahoo.com	Kandiyo Consulting, LLC	1200 Plymouth Avenue Minneapolis, MN 55411	Electronic Service	No	OFF_SL_24-200_Official
Michael	Krikava	mkrikava@taftlaw.com	Taft Stettinius & Hollister LLP	2200 IDS Center 80 S 8th St Minneapolis, MN 55402	Electronic Service	No	OFF_SL_24-200_Official
Corrina	Kumpe	ckumpe@mysunshare.com		N/A	Electronic Service	No	OFF_SL_24-200_Official
Mark	Larson	mlarson@meeker.coop	Meeker Coop Light & Power Assn	1725 Highway 12 E Ste 100 Litchfield, MN 55355	Electronic Service	No	OFF_SL_24-200_Official
Burnell	Lauer	blauer.sundial@gmail.com	Sundial Solar	3209 W. 76th St #305 Edina, MN 55435	Electronic Service	No	OFF_SL_24-200_Official

First Name	Last Name	Email	Company Name	Address	Delivery Method	View Trade Secret	Service List Name
Dean	Leischow	dean@sunrisenrg.com	Sunrise Energy Ventures	315 Manitoba Ave Ste 200 Wayzata, MN 55391	Electronic Service	No	OFF_SL_24-200_Official
Annie	Levenson Falk	annief@cupminnesota.org	Citizens Utility Board of Minnesota	332 Minnesota Street, Suite W1360 St. Paul, MN 55101	Electronic Service	No	OFF_SL_24-200_Official
Amy	Liberkowski	amy.a.liberkowski@xcelen ergy.com	Xcel Energy	414 Nicollet Mall 7th Floor Minneapolis, MN 554011993	Electronic Service	No	OFF_SL_24-200_Official
Carl	Linville	clinville@raponline.org	Regulatory Assistance Project	50 State Street Suite #3 Montpelier, VT 05602	Electronic Service	No	OFF_SL_24-200_Official
Phillip	Lipetsky	greenenergyproductsllc@g mail.com	Green Energy Products	PO Box 108 Springfield, MN 56087	Electronic Service	No	OFF_SL_24-200_Official
Jody	Londo	jody.l.londo@xcelenenergy.co m	Xcel Energy	414 Nicollet Mall 7th Floor Minneapolis, MN 554011993	Electronic Service	No	OFF_SL_24-200_Official
Brian	Lydic	brian@irecusa.org	Interstate Renewable Energy Council, Inc.	PO Box 1156 Latham, NY 12110-1156	Electronic Service	No	OFF_SL_24-200_Official
Richard	Macke	macker@powersystem.org	Power System Engineering, Inc.	10710 Town Square Dr NE Ste 201 Minneapolis, MN 55449	Electronic Service	No	OFF_SL_24-200_Official
Alex	Magerko	amagerko@epri.com	EPRI	942 Corridor Park Blvd Knoxville, TN 37932	Electronic Service	No	OFF_SL_24-200_Official

First Name	Last Name	Email	Company Name	Address	Delivery Method	View Trade Secret	Service List Name
Patrick	Mahlberg	pmahlberg@fredlaw.com	Fredrikson & Byron, P.A.	60 S Sixth St Ste 1500 Minneapolis, MN 55402-4400	Electronic Service	No	OFF_SL_24-200_Official
Jess	McCullough	jmccullough@mnpower.com	Minnesota Power	30 W Superior St Duluth, MN 55802	Electronic Service	No	OFF_SL_24-200_Official
Sara G	McGrane	smcgrane@felhaber.com	Felhaber Larson	220 S 6th St Ste 2200 Minneapolis, MN 55420	Electronic Service	No	OFF_SL_24-200_Official
Natalie	McIntire	natalie.mcintire@gmail.com	Wind on the Wires	570 Asbury St Ste 201 Saint Paul, MN 55104-1850	Electronic Service	No	OFF_SL_24-200_Official
Matthew	Melewski	matthew@nokomisenergy.com	Nokomis Energy LLC & Ole Solar LLC	2639 Nicollet Ave Ste 200 Minneapolis, MN 55408	Electronic Service	No	OFF_SL_24-200_Official
Thomas	Melone	Thomas.Melone@AllcoUS.com	Minnesota Go Solar LLC	222 South 9th Street Suite 1600 Minneapolis, MN 55120	Electronic Service	No	OFF_SL_24-200_Official
Tim	Mergen	tmergen@meeker.coop	Meeker Cooperative Light And Power	1725 US Hwy 12 E. Suite 100 PO Box 68 Litchfield, MN 55355	Electronic Service	No	OFF_SL_24-200_Official
Joseph	Meyer	joseph.c.meyer@state.mn.us	Office of Administrative Hearings	PO Box 64620 St. Paul, MN 55164	Electronic Service	Yes	OFF_SL_24-200_Official
Pontius	Mike	mpontius@mnpower.com		N/A	Electronic Service	No	OFF_SL_24-200_Official
Stacy	Miller	stacy.miller@minneapolismn.gov	City of Minneapolis	350 S. 5th Street Room M 301 Minneapolis, MN 55415	Electronic Service	No	OFF_SL_24-200_Official
Luther	Miller	Luther.C.Miller@xcelenergy.com	Xcel Energy	N/A	Electronic Service	No	OFF_SL_24-200_Official

First Name	Last Name	Email	Company Name	Address	Delivery Method	View Trade Secret	Service List Name
Darrick	Moe	darrick@mrea.org	Minnesota Rural Electric Association	11640 73rd Ave N Maple Grove, MN 55369	Electronic Service	No	OFF_SL_24-200_Official
David	Moeller	dmoeller@allete.com	Minnesota Power	30 W Superior St Duluth, MN 558022093	Electronic Service	No	OFF_SL_24-200_Official
Dalene	Monsebroten	dalene.monsebroten@nmp agency.com	Northern Municipal Power Agency	123 2nd St W Thief River Falls, MN 56701	Electronic Service	No	OFF_SL_24-200_Official
Andrew	Moratzka	andrew.moratzka@stoel.co m	Stoel Rives LLP	33 South Sixth St Ste 4200 Minneapolis, MN 55402	Electronic Service	No	OFF_SL_24-200_Official
Sergio	Navas	snavas@sundialsolarenerg y.com	Sundial Energy, LLC	3363 Republic Ave Saint Louis Park, MN 55426	Electronic Service	No	OFF_SL_24-200_Official
Ben	Nelson	benn@cmpasgroup.org	CMMPA	459 South Grove Street Blue Earth, MN 56013	Electronic Service	No	OFF_SL_24-200_Official
Alex	Nelson	ANelson@dakotaelectric.co m	Dakota Electric Association	4300 220nd St Farmington, MN 55024	Electronic Service	No	OFF_SL_24-200_Official
David	Niles	david.niles@avantenergy.c om	Minnesota Municipal Power Agency	220 South Sixth Street Suite 1300 Minneapolis, MN 55402	Electronic Service	No	OFF_SL_24-200_Official
Michael	Noble	noble@fresh-energy.org	Fresh Energy	408 Saint Peter St Ste 350 Saint Paul, MN 55102	Electronic Service	No	OFF_SL_24-200_Official
Rolf	Nordstrom	rnordstrom@gpisd.net	Great Plains Institute	2801 21ST AVE S STE 220 Minneapolis, MN 55407-1229	Electronic Service	No	OFF_SL_24-200_Official

First Name	Last Name	Email	Company Name	Address	Delivery Method	View Trade Secret	Service List Name
Samantha	Norris	samanthanorris@alliantenergy.com	Interstate Power and Light Company	200 1st Street SE PO Box 351 Cedar Rapids, IA 524060351	Electronic Service	No	OFF_SL_24-200_Official
Logan	O'Grady	logrady@mnseia.org	Minnesota Solar Energy Industries Association	2288 University Ave W St. Paul, MN 55114	Electronic Service	No	OFF_SL_24-200_Official
Timothy	O'Leary	toleary@llec.coop	Lyon-Lincoln Electric Cooperative, Inc	P.O. Box 639 Tyler, MN 561780639	Electronic Service	No	OFF_SL_24-200_Official
Jeff	O'Neill	jeff.oneill@ci.monticello.mn.us	City of Monticello	505 Walnut Street Suite 1 Monticello, MN 55362	Electronic Service	No	OFF_SL_24-200_Official
Russell	Olson	rolson@hcpd.com	Heartland Consumers Power District	PO Box 248 Madison, SD 570420248	Electronic Service	No	OFF_SL_24-200_Official
Wendi	Olson	wolson@otpc.com	Otter Tail Power Company	215 South Cascade Fergus Falls, MN 56537	Electronic Service	No	OFF_SL_24-200_Official
Bethany	Owen	bowen@mnpower.com	Minnesota Power	30 West Superior Street Duluth, MN 55802	Electronic Service	No	OFF_SL_24-200_Official
Cezar	Panait	Cezar.Panait@state.mn.us	Public Utilities Commission	121 7th Place East Suite 350 St. Paul, MN 55101	Electronic Service	No	OFF_SL_24-200_Official
Dan	Patry	dpatry@sunedison.com	SunEdison	600 Clipper Drive Belmont, CA 94002	Electronic Service	No	OFF_SL_24-200_Official
Jeffrey C	Paulson	jeff.jcplaw@comcast.net	Paulson Law Office, Ltd.	4445 W 77th Street Suite 224 Edina, MN 55435	Electronic Service	No	OFF_SL_24-200_Official

First Name	Last Name	Email	Company Name	Address	Delivery Method	View Trade Secret	Service List Name
Dean	Pawlowski	dpawlowski@otpc.com	Otter Tail Power Company	PO Box 496 215 S. Cascade St. Fergus Falls, MN 565370496	Electronic Service	No	OFF_SL_24-200_Official
Susan	Peirce	Susan.Peirce@state.mn.us	Department of Commerce	85 Seventh Place East St. Paul, MN 55101	Electronic Service	No	OFF_SL_24-200_Official
Mary Beth	Peranteau	mperanteau@fredlaw.com	Fredrikson & Byron, P.A.	44 East Mifflin Street Suite 1000 Madison, WI 53703	Electronic Service	No	OFF_SL_24-200_Official
Wess	Pfaff	wes.pfaff@mrenergy.com		N/A	Electronic Service	No	OFF_SL_24-200_Official
Donna	Pickard	dpickardgsss@gmail.com	Genie Solar Support Services	1215 Lilac Lane Excelsior, MN 55331	Electronic Service	No	OFF_SL_24-200_Official
Crystal	Pomerleau	crystal.r.pomerleau@xcelenergy.com	Xcel	N/A	Electronic Service	No	OFF_SL_24-200_Official
David G.	Prazak	dprazak@otpc.com	Otter Tail Power Company	P.O. Box 496 215 South Cascade Street Fergus Falls, MN 565380496	Electronic Service	No	OFF_SL_24-200_Official
Elizabeth	Psihos	elizabeth.psihos@idealenergies.com		N/A	Electronic Service	No	OFF_SL_24-200_Official
Michael	Reinertson	michael.reinertson@avantenergy.com	Avant Energy	220 S. Sixth St. Ste 1300 Minneapolis, MN 55402	Electronic Service	No	OFF_SL_24-200_Official
John C.	Reinhardt	N/A	Laura A. Reinhardt	3552 26th Ave S Minneapolis, MN 55406	Paper Service	No	OFF_SL_24-200_Official
Generic Notice	Residential Utilities Division	residential.utilities@ag.state.mn.us	Office of the Attorney General-RUD	1400 BRM Tower 445 Minnesota St St. Paul, MN 551012131	Electronic Service	Yes	OFF_SL_24-200_Official

First Name	Last Name	Email	Company Name	Address	Delivery Method	View Trade Secret	Service List Name
Kevin	Reuther	kreuther@mncenter.org	MN Center for Environmental Advocacy	26 E Exchange St, Ste 206 St. Paul, MN 551011667	Electronic Service	No	OFF_SL_24-200_Official
Kristi	Robinson	krobinson@star-energy.com	STAR Energy Services, LLC	1401 South Broadway Pelican Rapids, MN 56572	Electronic Service	No	OFF_SL_24-200_Official
Daniel	Rogers	dan@nokomispartners.com	Nokomis	2639 Nicollet Ave Ste 200 Minneapolis, MN 55408	Electronic Service	No	OFF_SL_24-200_Official
Michael	Ruiz	michael.ruiz@xcelenergy.com	Xcel Energy	N/A	Electronic Service	No	OFF_SL_24-200_Official
Darla	Ruschen	d.ruschen@bcrea.coop	Brown County Rural Electric Assn.	PO Box 529 24386 State Highway 4 Sleepy Eye, MN 56085	Electronic Service	No	OFF_SL_24-200_Official
Robert K.	Sahr	bsahr@eastriver.coop	East River Electric Power Cooperative	P.O. Box 227 Madison, SD 57042	Electronic Service	No	OFF_SL_24-200_Official
Kenric	Scheevel	Kenric.scheevel@dairylandpower.com	Dairyland Power Cooperative	3200 East Ave S PO Box 817 La Crosse, WI 54602	Electronic Service	No	OFF_SL_24-200_Official
Dean	Schiro	dean.e.schiro@xcelenergy.com	Xcel Energy	N/A	Electronic Service	No	OFF_SL_24-200_Official
Jacob J.	Schlesinger	jschlesinger@keyesfox.com	Keyes & Fox LLP	1580 Lincoln St Ste 880 Denver, CO 80203	Electronic Service	No	OFF_SL_24-200_Official
Jeff	Schoenecker	jschoenecker@dakotaelectric.com	Dakota Electric Association	4300 220th Street W Farmington, MN 55024	Electronic Service	No	OFF_SL_24-200_Official
Kay	Schraeder	kschraeder@minnkota.com	Minnkota Power	5301 32nd Ave S Grand Forks, ND 58201	Electronic Service	No	OFF_SL_24-200_Official

First Name	Last Name	Email	Company Name	Address	Delivery Method	View Trade Secret	Service List Name
Matthew	Schuerger	matthew.schuerger@state.mn.us	Public Utilities Commission	121 7th Place East Suite 350 St. Paul, MN 55101	Electronic Service	No	OFF_SL_24-200_Official
Ronald J.	Schwartau	rschwartau@noblesce.com	Nobles Cooperative Electric	22636 U.S. Hwy. 59 Worthington, MN 56187	Electronic Service	No	OFF_SL_24-200_Official
Christine	Schwartz	Regulatory.records@xcelenergy.com	Xcel Energy	414 Nicollet Mall FL 7 Minneapolis, MN 554011993	Electronic Service	No	OFF_SL_24-200_Official
Rob	Scott Hovland	rob.scott-hovland@mrenergy.com	Missouri River Energy Services	3724 W Avera Dr PO Box 88920 Sioux Falls, SD 571098920	Electronic Service	No	OFF_SL_24-200_Official
Dean	Sedgwick	Sedgwick@Itascapower.com	Itasca Power Company	PO Box 455 Spring Lake, MN 56680	Electronic Service	No	OFF_SL_24-200_Official
Will	Seuffert	Will.Seuffert@state.mn.us	Public Utilities Commission	121 7th PI E Ste 350 Saint Paul, MN 55101	Electronic Service	Yes	OFF_SL_24-200_Official
Janet	Shaddix Elling	jshaddix@janetshaddix.com	Shaddix And Associates	7400 Lyndale Ave S Ste 190 Richfield, MN 55423	Electronic Service	Yes	OFF_SL_24-200_Official
Doug	Shoemaker	dougs@charter.net	Minnesota Renewable Energy	2928 5th Ave S Minneapolis, MN 55408	Electronic Service	No	OFF_SL_24-200_Official
Felicia	Skaggs	fskaggs@meeker.coop	Meeker Cooperative Light & Power	1725 US Highway 12 E Suite 100 Litchfield, MN 55355	Electronic Service	No	OFF_SL_24-200_Official
Glen	Skarbakka	glen@s-pllc.com	Skarbakka PLLC	5411 Bartlett Blvd Mound, MN 55364	Electronic Service	No	OFF_SL_24-200_Official

First Name	Last Name	Email	Company Name	Address	Delivery Method	View Trade Secret	Service List Name
Trevor	Smith	trevor.smith@avantenergy.com	Avant Energy, Inc.	220 South Sixth Street Suite 1300 Minneapolis, MN 55402	Electronic Service	No	OFF_SL_24-200_Official
Rafi	Sohail	rafi.sohail@centerpointenergy.com	CenterPoint Energy	800 LaSalle Avenue P.O. Box 59038 Minneapolis, MN 554590038	Electronic Service	No	OFF_SL_24-200_Official
Beth	Soholt	bsoholt@cleangridalliance.org	Clean Grid Alliance	570 Asbury Street Suite 201 St. Paul, MN 55104	Electronic Service	No	OFF_SL_24-200_Official
Marcia	Solie	m.solie@bcrea.coop	Brown County Rural Electrical Assn.	24386 State Hwy. 4, PO Box 529 Sleepy Eye, MN 56085	Electronic Service	No	OFF_SL_24-200_Official
Braden	Solum	braden.solum@idealenergies.com	iDEAL Energies	5810 Nicollet Ave Minneapolis, MN 55419	Electronic Service	No	OFF_SL_24-200_Official
Robyn	Sonstegard	robyn.s@northstarelectric.coop	North Star Electric Cooperative, Inc.	PO BOX 719 Baudette, MN 56623	Electronic Service	No	OFF_SL_24-200_Official
Faith	Spotted Eagle	eagletrax@hotmail.com		PO BOX 667 Lake Andes, SD 557356	Electronic Service	No	OFF_SL_24-200_Official
Brandon	Stamp	brandon.j.stamp@xcelenergy.com	Xcel Energy	401 Nicollet Mall Minneapolis, MN 55401	Electronic Service	No	OFF_SL_24-200_Official
Sky	Stanfield	stanfield@smwlaw.com	Shute, Mihaly & Weinberger	396 Hayes Street San Francisco, CA 94102	Electronic Service	No	OFF_SL_24-200_Official

First Name	Last Name	Email	Company Name	Address	Delivery Method	View Trade Secret	Service List Name
Kristin	Stastny	kstastny@taftlaw.com	Taft Stettinius & Hollister LLP	2200 IDS Center 80 South 8th St Minneapolis, MN 55402	Electronic Service	No	OFF_SL_24-200_Official
Eric	Swanson	eswanson@winthrop.com	Winthrop & Weinstine	225 S 6th St Ste 3500 Capella Tower Minneapolis, MN 554024629	Electronic Service	No	OFF_SL_24-200_Official
Sherry	Swanson	sswanson@noblesce.com	Nobles Cooperative Electric	22636 US Highway 59 PO Box 788 Worthington, MN 56187	Electronic Service	No	OFF_SL_24-200_Official
Bryant	Tauer	btauer@whe.org	Wright-Hennepin	6800 Electric Dr Rockford, MN 55373	Electronic Service	No	OFF_SL_24-200_Official
Emma Marshall	Torres	emarshall-torres@convergentep.com		N/A	Electronic Service	No	OFF_SL_24-200_Official
Pat	Treseler	pat.jcplaw@comcast.net	Paulson Law Office LTD	4445 W 77th Street Suite 224 Edina, MN 55435	Electronic Service	No	OFF_SL_24-200_Official
Jeff	Triplett	triplettj@powersystem.org	MREA	10710 Town Square Dr NW St 201 Minneapolis, MN 55449	Electronic Service	No	OFF_SL_24-200_Official
Adam	Tromblay	atromblay@noblesce.com	Nobles Cooperative Electric	22636 US Hwy. 59 P.O. Box 788 Worthington, MN 56187-0788	Electronic Service	No	OFF_SL_24-200_Official
Lise	Trudeau	lise.trudeau@state.mn.us	Department of Commerce	85 7th Place East Suite 500 Saint Paul, MN 55101	Electronic Service	No	OFF_SL_24-200_Official
Alan	Urban	alan.m.urban@xcelenergy.com	Xcel Energy	N/A	Electronic Service	No	OFF_SL_24-200_Official

First Name	Last Name	Email	Company Name	Address	Delivery Method	View Trade Secret	Service List Name
Ellen	Veazey	lveazey@solarunitedneighbors.org	Solar United Neighbors	1350 Connecticut Ave NW Ste 412 Washington, DC 20036	Electronic Service	No	OFF_SL_24-200_Official
Sam	Villella	sdvillella@gmail.com		10534 Alamo Street NE Blaine, MN 55449	Electronic Service	No	OFF_SL_24-200_Official
Wendy	Vorasane	wendy.vorasane@idealenergy.com		N/A	Electronic Service	No	OFF_SL_24-200_Official
Sarah	Walinga	swalinga@solarcity.com	Energy Freedom Coalition	3055 Clearview Way San Mateo, MN 94402	Electronic Service	No	OFF_SL_24-200_Official
Robert	Walsh	bwalsh@mnvalleyrec.com	Minnesota Valley Coop Light and Power	PO Box 248 501 S 1st St Montevideo, MN 56265	Electronic Service	No	OFF_SL_24-200_Official
Roger	Warehime	roger.warehime@owatonnautilities.com	Owatonna Municipal Public Utilities	208 S Walnut Ave PO BOX 800 Owatonna, MN 55060	Electronic Service	No	OFF_SL_24-200_Official
Jenna	Warmuth	jwarmuth@mnpower.com	Minnesota Power	30 W Superior St Duluth, MN 55802-2093	Electronic Service	No	OFF_SL_24-200_Official
Samantha	Weaver	samantha@communitysolaraccess.org	Coalition for Community Solar Access	1380 Monroe St. Washington DC, DC 20010	Electronic Service	No	OFF_SL_24-200_Official
Elizabeth	Wefel	eawefel@flahertyhood.com	Flaherty & Hood, P.A.	525 Park St Ste 470 Saint Paul, MN 55103	Electronic Service	No	OFF_SL_24-200_Official
John	Williamson	John.Williamson@state.mn.us	Minnesota Department of Labor and Industry	443 Lafayette Rd N St. Paul, MN 55155-4341	Electronic Service	No	OFF_SL_24-200_Official

First Name	Last Name	Email	Company Name	Address	Delivery Method	View Trade Secret	Service List Name
Danielle	Winner	danielle.winner@state.mn.us	Department of Commerce	85 7th Place East Suite 500 Saint Paul, MN 55101	Electronic Service	No	OFF_SL_24-200_Official
Robyn	Woeste	robynwoeste@alliantenergy.com	Interstate Power and Light Company	200 First St SE Cedar Rapids, IA 52401	Electronic Service	No	OFF_SL_24-200_Official
Terry	Wolf	terry.wolf@mrenergy.com	Missouri River Energy Services	3724 W Avera Dr PO Box Sioux Falls, SD 571098920	Electronic Service	No	OFF_SL_24-200_Official
Brian	Zavesky	brianz@mrenergy.com	Missouri River Energy Services	3724 West Avera Drive P.O. Box 88920 Sioux Falls, SD 57108-8920	Electronic Service	No	OFF_SL_24-200_Official