

# **APPENDIX A**

## **Notice of Project and Open Houses to Local Governmental Units (Example Letter)**

**THIS PAGE INTENTIONALLY BLANK**



GREAT RIVER  
ENERGY®

12300 Elm Creek Boulevard • Maple Grove, Minnesota 55369-4718 • 763-445-5000 • Fax 763-445-5050 • www.GreatRiverEnergy.com

January 4, 2013

Elko New Market & Cleary Lake  
W.O. 201719

Corey Schweich, Public Works & Engineering  
City of Elko New Market  
PO Box 99  
Elko New Market, MN 55020

**SUBJECT:** Open house meetings for proposed Great River Energy 115 kilovolt (kV)  
transmission upgrade project in the Elko New Market and Cleary Lake areas

Hello,

We are writing to invite you to an open house informational meeting regarding a transmission upgrade project being proposed in your area by Great River Energy, power supplier to Minnesota Valley Electric Cooperative and 27 other Minnesota cooperatives.

Two open house meetings will be held\*. Representatives of Great River Energy will be available to answer questions and provide you with more information regarding the proposed project.

**Scott County Library - Elko New Market branch**  
**110 J. Roberts Way, Elko New Market**  
**Tues., Jan. 15, 2013**  
**6:30 to 8p.m.**

or

**Prior Lake High School**  
**7575 150<sup>th</sup> Street West**  
**Savage, MN 55378**  
**Wed., Jan. 16, 2013**  
**6:30 to 8p.m.**

*\*Please feel free to attend the meeting that is most convenient for you.  
It is not necessary to attend both. No formal presentation will be given at either meeting.  
Please feel free to come at any time during the hours indicated.*

**The proposed project includes:**

- Construction of approximately 5.4 miles of new, double circuit transmission line to 115 kV standards from the New Market-Elko "MV-PN" line to Xcel Energy's Veseli 69 kV Breaker Station

January 4, 2013  
Page Two

- Rebuild to 115 kV standards approximately 3.5 miles of the existing Great River Energy single circuit 69 kV "MV-PN" line from Prior Lake Junction south to Credit River Junction
- Rebuild to 115 kV standards approximately 2.4 miles of the existing Great River Energy single circuit 69 kV "MV-CR" line from Credit River Junction west past Minnesota Valley Electric Cooperative's Cleary Lake Substation to Xcel Energy's Credit River Substation
- Rebuild to 115 kV standards approximately 5.6 miles of the existing Great River Energy single circuit 69 kV "MV-PN" line along 250<sup>th</sup> Street between Panama Avenue and Natchez Avenue
- Permit to operate at 115 kV the 2 miles of existing Great River Energy double circuit 69 kV line between the new Chub Lake Substation and Natchez Avenue. (This will be strung on quad circuit structures as part of the CapX2020 Brookings 345 kV project.)

The enclosed fact sheet provides additional details about the proposed project and the proposed general location of the facilities to be constructed by Great River Energy.

#### **The permitting process**

A Certificate of Need and a Route Permit are required for this proposed project under current State of Minnesota rules. To learn about the state permitting process and your opportunities to participate, please refer to the enclosed fact sheet.

If you are an agency (Corps of Engineers, DNR, SHPO, USFWS, MnDOT- Aeronautics) a letter requesting review of the project has already been directed to staff members assigned to this geographic area.

If you have any questions regarding this proposed project or the open house, please contact me at 763-445-5976 or email me at pschaub@grenergy.com.

Sincerely,

Great River Energy

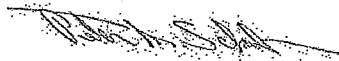

Peter M. Schaub  
Sr. Field Representative

Enclosures

PS:\ve\erntfs\shared\Transmission\Capital Projects\201610 - New Market and Cleary Lake Area Projects\201719 - New Market to Vesell 6 mi. 115kV Double Circuit\LR-ENV\Land Rights\Notification Letters\Elko Final Open House Notice Letter.docxdocx

# **APPENDIX B**

## **Exemption Order**

**THIS PAGE INTENTIONALLY BLANK**

BEFORE THE MINNESOTA PUBLIC UTILITIES COMMISSION

Beverly Jones Heydinger  
David C. Boyd  
J. Dennis O'Brien  
Phyllis A. Reha  
Betsy Wergin

Chair  
Commissioner  
Commissioner  
Commissioner  
Commissioner

In the Matter of the Application of Great River Energy for a Certificate of Need for a 115 kV Transmission Line Project in the Elko, New Market, and Cleary Lake Areas in Scott and Rice Counties

ISSUE DATE: February 4, 2013

DOCKET NO. ET-2/CN-12-1235

ORDER MODIFYING AND APPROVING NOTICE PLAN AND EXEMPTION REQUESTS

**PROCEDURAL HISTORY**

On November 9, 2012, Great River Energy (the Applicant) filed a notice plan petition under Minn. Rules, chapter 7849.2550 and a request for exemption from certain data requirements under Minn. Rules 7849.0200. subp. 6, in connection with an anticipated certificate of need application.

The only party to comment on either filing was the Minnesota Department of Commerce (the Department), which recommended granting both petitions with modifications. Great River Energy accepted the Department's recommendations on its exemption request and did not oppose the Department's recommendations on its proposed notice plan.

On January 24, 2013, the Commission met to consider the matter.

**FINDINGS AND CONCLUSIONS**

**I. Proposed Project**

The proposed project is a 115 kV transmission line in the Elko, New Market, and Cleary Lake areas of Scott and Rice counties. The project is a combination of 1) rebuilds and upgrades to approximately 13.6 miles of single and double circuit 69 kV transmission lines to 115 kV; 2) construction of approximately 5.4 miles of new double circuit 115 kV capable transmission lines; and 3) construction of a new 69 kV breaker station. Applicant states that it intends to file its certificate of need application in March 2013.

**II. Proposed Notice Plan**

The Department reviewed the Applicant's proposed notice plan under Minn. Rules, part 7829.2550, subp. 3, which requires an applicant to file a proposed notice plan designed to notify all

persons reasonably likely to be affected by the proposed line. The rule requires such plans to include direct mail notice to landowners, tribal governments, local governments and other governmental entities, as well as to all mailing addresses within the area reasonably likely to be affected by the line.

The rule also requires newspaper notice to members of the public in areas reasonably likely to be affected by the proposed line. The notice must contain information regarding the project, including a map of the proposed line and other existing facilities, as well as a statement that the line cannot be constructed unless the Commission certifies that it is needed.

In its evaluation of the proposed notice plan, the Department recommended that the Commission approve Applicant's proposed notice plan, modified to include the following:

- notice publication in the *Savage Pacer*;
- minor language revisions to the notice content, largely editorial or stylistic;<sup>1</sup> and
- clarification that the "Notice Area" of 1000 feet surrounding the project is satisfactory, as long as the subsequent route permit application is submitted with a request for a lesser route width.

Having considered the Applicant's proposed notice plan, the Commission concurs with the Department that the plan meets the requirements contained in Minn. Rules, part 7829.2550, with the modifications recommended by the Department. Accordingly, the Commission approves the notice plan with the modifications recommended by the Department.

### **III. Rule Variances**

The Applicant requested that the Commission grant a variance to Minn. Rules, part 7829.2500, subp. 5, which requires an applicant to publish a newspaper notice upon filing a certificate of need application, stating that it will publish newspaper notice of the certificate of need filing as part of the notice plan implementation no more than 60 days before its certificate of need application.

The Applicant also requested that the Commission grant a variance to Minn. Rules, part 7829.2550, subp. 6, which requires an applicant to implement the proposed notice plan within 30 days of approval by the Commission. The Applicant has instead requested to implement the notice plan no more than 60 days and no less than two weeks prior to the filing of the certificate of need application to allow the notice to more closely coincide with the certificate of need filing.

Applicant asserts that should the Commission grant a variance to the rules, the two newspaper notices for the notice plan and the certificate of need application could be combined. Applicant states that it would publish newspaper notice of the certificate of need application in newspapers of local and regional circulation up to 60 days before and no less than two weeks prior to the filing of the certificate of need application.

---

<sup>1</sup> The Department's recommendations regarding the minor language revisions are found in Attachment A to this Order.



### **A. Legal Standard for Varying Rules**

Under Minn. Rules, part 7829.3200, the Commission is authorized to vary any of its rules upon making the following findings:

- 1) enforcement of the rule would impose an excessive burden upon the applicant or others affected by the rule;
- 2) granting the variance would not adversely affect the public interest; and
- 3) granting the variance would not conflict with standards imposed by law.

The Department supported varying the rules, stating that enforcement of the rules would burden all parties involved by separating the provision of notice from the start of the proceeding; that enforcement of the rules would not adversely affect the public interest and would better tie the implementation of notice to the beginning of the certificate of need proceeding; and that the Department is not aware that the variances requested would conflict with standards imposed by law.

### **B. Commission Action**

The Commission concurs with the parties and will vary the requirement of Minn. Rules, part 7829.2500, subp. 5 that an applicant publish a separate newspaper notice upon the filing of a certificate of need application, instead authorizing the newspaper notices for the notice plan and certificate of need to be combined. The Commission will also vary the 30-day time line of Minn. Rules, part 7829.2550, subp. 6. In granting these variances, the Commission makes the following findings:

- 1) Enforcing the rules would impose an excessive burden upon the public and upon parties to the proceeding by separating the delivery of the notice from the start of the certificate of need proceeding;
- 2) Granting the variances would not adversely affect the public interest and would in fact serve the public interest since implementation of the notice plan would more closely coincide with the beginning of the certificate of need process; and
- 3) Varying the 30-day time line would not conflict with any other standards imposed by law.

## **IV. Exemption Request**

### **A. In General**

Commission rules list the types of information that might be useful for evaluating the need for a large energy facility, and direct utilities to file this information with their certificate of need applications. But not every type of information listed is relevant or appropriate to every type of large energy facility. Consequently, the rules provide for applicants to seek exemptions from these rules whenever “the data requirement is unnecessary to determine the need for the proposed facility. . . .”<sup>2</sup> In this manner, the certificate of need filing requirements are tailored to the circumstances of each proposal.

---

<sup>2</sup> Minn. Rules, part 7849.0200, subp. 6.

## **B. Applicant's Request**

Applicant requested exemption from providing data requested under the following portions of Minnesota Rules:

- Minnesota Rule 7849.0260, subparts A(3) and C(6) -- Line Losses;
- Minnesota Rule 7849.0270, subparts 1 and 2 --Line Losses;
- Minnesota Rule 7849.0270, subparts 2(B) and 2(C) -- Customer Class Information;
- Minnesota Rule 7849.0270, subpart 2(C) -- Annual Peak Demand –;
- Minnesota Rule 7849.0270, subpart 2(D) -- Monthly Peak Demand;
- Minnesota Rule 7849.0270, subpart 2(E) -- Revenue Requirements –;
- Minnesota Rule 7849.0270, subpart 2(F) -- Weekday Load Factor –;
- Minnesota Rule 7849.0270, subparts 3 through 5 -- Forecast Methodology;
- Minnesota Rule 7849.0280 (A) and (H) -- System Capacity –;
- Minnesota Rule 7849.0280 (B) through (G) and (I) -- System Capacity –;
- Minnesota Rule 7849.0290 -- Conservation;
- Minnesota Rule 7849.0300 -- Consequences of Delay; and
- Minnesota Rule 7849.0340 -- No-Facility Alternative –

Applicant stated that in accordance with Minn. Rules, part 7849.0200, subp. 6, the Commission could grant an exemption from providing certain information as part of a certificate of need application if the applicant requested an exemption in writing that showed that the data requirement was either unnecessary to determine the need for the proposed facility or that the requirement could be satisfied by submitting another document. With respect to each rule from which it seeks exemption, Applicant has undertaken to make such a showing.

## **C. The Department's Comments and Recommendations**

The Department submitted a detailed analysis of each of the Applicant's exemption requests. The Department concluded that the Commission should grant the requested exemptions, but modified the substitute data that Applicant proposed to provide with respect to certain data requirements.

Applicant filed comments agreeing with the Department's recommendations regarding its exemption requests, and agreeing to provide substation-specific level data for both cooperative and non-cooperative owned substations in its certificate of need application.

## **D. Commission Action**

Minnesota Rules 7849.0200, subp. 6 states:

Before submitting an application, a person is exempted from any data requirement of this chapter if the person (1) requests an exemption from specified rules, in writing to the commission and (2) shows that the data requirement is unnecessary to determine the need for the proposed facility or may be satisfied by submitting another document.

The Commission has reviewed the Department's detailed examination of Applicant's exemption requests, and concurs in its analysis, and grants the requests, incorporating the modifications set forth in the Department's December 19, 2012 comments.

## ORDER

1. The Commission approves the proposed notice plan as modified by the Department in its comments, and as reflected in Attachment A hereto.
2. The Commission varies Minn. Rules, part 7829.2500, subp. 5, and permits Applicant to combine publishing the newspaper notices for the notice plan and certificate of need upon filing a certificate of need application.
3. The Commission varies Minn. Rules, part 7829.2550, subp.6, and authorizes Applicant to implement the notice plan no more than 60 days and no less than two weeks prior to the filing of the certificate of need application.
4. The Commission grants the exemption requests, modified to incorporate the Department's proposed modifications to the substitute data proposed by Applicant.
5. This Order shall become effective immediately.

BY ORDER OF THE COMMISSION

Burl W. Haar  
Executive Secretary



This document can be made available in alternative formats (i.e., large print or audio tape) by calling 651.296.0406 (voice). Persons with hearing or speech disabilities may call us through Minnesota Relay at 1.800.627.3529 or by dialing 711.

*Applicant's Proposed Notice Plan, Attachment C (second page, fourth paragraph) and Attachment D (second page, last paragraph)*

In addition to certifying the Project, the Commission must also grant a Route Permit for the Project. The routing of the Project is governed by Minnesota law, including Minnesota Statutes Chapter 216E and Minnesota Rules Chapter 7850, specifically Rules 7850.2900 to 7850.4600, as they pertain to the alternative permitting process. Information on the Route Permit application, once filed, can be obtained by visiting the Department of Commerce Energy Facility Permitting ("EFP") Commission's website in Docket No. ET2/TL-12-\_\_\_ at <http://mn.gov/commerce/energyfacilities/Docket.html?Id=32989>.

*Applicant's Proposed Notice Plan Attachment C (second page, last paragraph) and Attachment D (third page, first paragraph)*

~~Minnesota Department of Commerce Energy Facility Permitting EFP~~ staff ("EFP") is responsible for conducting environmental review of the Project. ~~EFP staff will prepare is~~ responsible for preparing an environmental report ("ER") for the Certificate of Need proceeding. EFP staff will prepare is also responsible for preparing an environmental assessment ("EA") for the Route Permit proceeding. EFP staff may elect to combine these two documents and issue one document, an EA in lieu of an ER, which satisfies the environmental review requirements for the Certificate of Need and Route Permit proceedings.

*Applicant's Proposed Notice Plan Attachment C (fourth page, Department of Commerce contact information), Attachment D (fourth page, Department of Commerce contact information), Attachment H (second page, Department of Commerce contact information)*

Minnesota Department of Commerce

~~Deborah Pile David Birkholz~~, State Permit Manager  
85 7th Place East, Suite 500  
St. Paul, Minnesota 55101  
~~651.297.2375-296.2878~~  
800.657.3794

~~deborah.pile-david.birkholz@state.mn.us~~

*Applicant's Proposed Notice Plan Attachment C (third page, last paragraph) and Attachment D (fifth page, first paragraph), Attachment H (second page, fifth paragraph)*

If you would like to have your name added to the Project Route Permit mailing list (Docket No. ET2/TL-12-\_\_\_ -1245), you may register by visiting the Department of Commerce webpage at [mn.gov/commerce/energyfacilities/](http://mn.gov/commerce/energyfacilities/), clicking on the "Transmission Lines" tab, selecting the link for the 115 kV Transmission Line Project in the Elko New Market and Cleary Lake Areas from the listed projects, and then clicking the links next to the "Mailing List" heading. Alternately, you may contact Department of Commerce staff at the address above. ~~Please be aware that the Route Permit mailing list may not be available for online registration until the Route Permit application is submitted.~~



85 7th Place East, Suite 500, St. Paul, MN 55101-2198

main: 651.296.4026

tty: 651.296.2860

fax: 651.297.7891

[www.energy.mn.gov](http://www.energy.mn.gov)

December 19, 2012

Burl W. Haar  
Executive Secretary  
Minnesota Public Utilities Commission  
121 7<sup>th</sup> Place East, Suite 350  
St. Paul, Minnesota 55101-2147

RE: **Comments of the Minnesota Department of Commerce, Division of Energy Resources**  
Docket No. ET2/CN-12-1235

Dear Dr. Haar:

Attached are the comments of the Minnesota Department of Commerce, Division of Energy Resources (Department) in the following matter:

Exemption Request Petition for the Application of Great River Energy for a Certificate of Need for its 115 kV Transmission Line Project in the Elko New Market and Cleary Lake Areas in Scott, and Rice Counties, Minnesota.

The petition was filed on November 9, 2012. The petitioner is:

Kodi J. Church  
Briggs and Morgan  
2200 IDS Center  
80 South 8<sup>th</sup> Street  
Minneapolis, Minnesota 55402

The Department recommends **approval with modifications** and is available to answer any questions the Minnesota Public Utilities Commission may have.

Sincerely,

/s/ SACHIN SHAH  
Rates Analyst

SS/ja  
Attachment



---

BEFORE THE MINNESOTA PUBLIC UTILITIES COMMISSION

COMMENTS OF THE  
MINNESOTA DEPARTMENT OF COMMERCE  
DIVISION OF ENERGY RESOURCES

DOCKET NO. ET2/CN-12-1235

**I. BACKGROUND**

On November 9, 2012 Great River Energy (GRE or the Applicant) filed GRE's *Notice Plan Petition for the Application of Great River Energy for a Certificate of Need for its 115 kV Transmission Line Project in the Elko New Market and Cleary Lake Areas in Scott and Rice Counties, Minnesota* (Notice Petition). The Notice Petition provided GRE's proposed notice plan to communicate its intent to rebuild or construct 69/115 kilovolt (kV) transmission lines near the City of Prior Lake, the City of Savage, Cleary Lake, Spring Lake Township, Credit River Township, Cedar Lake Township, New Market Township, the City of Elko New Market and Wheatland Township in Scott and Rice Counties, Minnesota (Project). Portions of approximately 12 miles of 69 kV transmission lines are intended to be rebuilt, 2 miles are currently under construction, and a new 5.4-mile double circuit transmission line between the New Market-Elko line and Xcel Energy's Veseli breaker station will be proposed. The Project, according to GRE, is intended to alleviate the identified transmission load-serving deficiencies on the 69 kV transmission systems to the west of the Project area bounded by the Scott County, Carver County, Owatonna, and Faribault substations ("Scott-Faribault System").

The Notice Petition provided a plan to notify potentially affected members of the public about the proposal, under Minnesota Rules part 7849.2550. In response to the Notice Petition, comments were filed by the Minnesota Department of Commerce-Division of Energy Resources (Department). The Notice Petition is currently pending before the Minnesota Public Utilities Commission (Commission).

On November 9, 2012 GRE submitted the Applicant's *Exemption Request Petition for the Application of Great River Energy for a Certificate of Need for its 115 kV Transmission Line Project in the Elko New Market and Cleary Lake Areas in Scott, and Rice Counties, Minnesota* (Exemption Petition) to obtain exemption from certain data requirements of Minnesota Rules part 7849. In response to the Exemption Petition, on December 6, 2012 the Commission issued a

notice specifying that comments are due December 19, 2012 and reply comments are due December 28, 2012.

Below are the comments of the Department on the Exemption Petition.

## **II. DEPARTMENT ANALYSIS**

### **A. INTRODUCTION**

As mentioned above, the Project, in general, is a combination of rebuilds and upgrades of single and double circuit 69 kV transmission lines to 115 kV; construction of new double circuit 115 kV capable transmission lines; and construction of a new 69kV breaker station as described above.

According to GRE, the Project is made up of two general segments as follows:

1. the system in the Scott-Faribault area to the south; and
2. the system in the Cleary Lake area to the north.

The proposed facilities qualify as large energy facilities (LEF) under Minnesota Statutes §216B.2421, subd. 2 [(2) and (3)]. Minnesota Statute §216B.243, subd. 2 requires that LEFs obtain a Certificate of Need (CN). Minnesota Rules part 7849 includes the filing requirements for a CN for an electric transmission facility.

The Exemption Petition stated that the proposed Project is expected to maintain local reliability and is intended to alleviate the identified transmission load-serving deficiencies on the 69 kV transmission systems to the west of the Project area bounded by the Scott County, Carver County, Owatonna, and Faribault substations (“Scott-Faribault System”). A detailed description of the proposal and claimed need for the Project, according to GRE on pages 3 and 4 of their Exemption Petition, is as follows:

Great River Energy’s most recent annual Transmission System Assessment Study (“TSAS”) identified load-serving deficiencies, both low voltage and transmission system overloads, in the extensive Scott-Faribault 69 kV system (Attachment A). A detailed study of this 69 kV system, known as the New Prague Area Study (“NPAS”), was completed and resulted in engineers identifying the need to connect the Scott-Faribault System with the 69 kV transmission system that is served by the Glendale and Lake Marion substations (“Cleary-Elko System”) by 2016 to address these deficiencies.

To connect these two systems (the Scott-Faribault and Cleary-Elko systems), a new breaker station near the existing Veseli Distribution Substation in Wheaton Township and a double circuit

transmission line between this breaker station and the existing New Market Substation are required. Modeling and forecasting determined that the existing 69 kV transmission line between the Chub Lake (under construction) and New Market substations was of insufficient capacity to support the system after the connection of the Scott-Faribault and Cleary-Elko systems in 2016 was completed. Further, within the Cleary- Elko System, two existing 69 kV lines are of immediate concern for thermal overload and must be rebuilt, even if the Cleary-Elko and Scott Faribault systems were not connected:

1. Prior Lake Junction – Credit River Junction – Cleary Lake Tap 69 kV transmission line (also known as the “MV-PN” line) and
2. Cleary Lake Tap – Credit River Tap 69 kV transmission line (also known as the “MV-CR” line).

Although the immediate concerns with the lines identified above in the Cleary-Elko System and the forecasted low voltage and overload problems in the Scott-Faribault System could be addressed by rebuilding the 69 kV transmission lines and constructing a 69 kV double circuit transmission line between the New Market Substation and the proposed Veseli Breaker Station, engineering analysis has determined that the Cleary-Elko System will need to be operated at 115 kV within the transmission planning horizon. System needs and forecasts indicate that by 2022, a circuit between the Chub Lake Substation and the Veseli Breaker Station would need to be operated at 115 kV.<sup>1</sup> Additionally, 115 kV operation of the line from Credit River to Prior Lake Junction is anticipated to be necessary to provide adequate service in the Cleary Lake area by approximately 2030.

#### *B. GRE’S REQUEST*

In the Exemption Petition, the Applicant requested that the Commission grant certain exemptions from the application requirements contained in Minnesota Rules Chapter 7849. Specifically, GRE requested exemption from the following portions of Minnesota Rules:

- 7849.0260, Subp. A(3) and C(6); Line Losses;
- 7849.0270, Subp. 1, 2; Forecasting; System-Wide Data
- 7849.0270, Subp. 2 (B and C); Customer Class Information;
- 7849.0270, Subp. 2(C); Annual Peak Demand;

---

<sup>1</sup> GRE stated that to allow this connection, a 115/69 kV transformer would need to be added to what will become the existing footprint of the Veseli Breaker Station.



- 7849.0270, Subp. 2(D); Monthly Peak Demand;
- 7849.0270, Subp. 2(E); System Revenue Requirements;
- 7849.0270, Subp. 2(F); Weekday Load Factor;
- 7849.0270, Subp. 3 – 5; Forecast Methodology;
- 7849.0280, (A) through (H); System Capacity;
- 7849.0280, (B) through (G) and (I); System Capacity;
- 7849.0290; Conservation;
- 7849.0300; Consequences of Delay; and
- 7849.0340; No-Facility Alternative.

Minnesota Rules 7849.0200 states that an exemption is appropriate if the data requirement is not necessary to determine the need or is obtained via another document:

Before submitting an application, a person is exempted from any data requirement of parts 7849.0010 to 7849.0400 if the person (1) requests an exemption from specified rules, in writing to the commission, and (2) shows that the data requirement is unnecessary to determine the need for the proposed facility or may be satisfied by submitting another document. A request for exemption must be filed at least 45 days before submitting an application. The commission shall respond in writing to a request for exemption within 30 days of receipt and include the reasons for the decision. The commission shall file a statement of exemptions granted and reasons for granting them before beginning the hearing.

The Department notes that the applicant bears the burden of proving the claimed need of the proposed project. In the Commission's July 24, 2006 ORDER GRANTING EXEMPTIONS, *In the Matter of the Application for Certificates of Need for Three 115 kV Transmission Lines in Southwestern Minnesota*, in Docket No. E002/CN-06-154, the Commission stated in part the following:

It should be understood that no decision the Commission makes regarding Xcel's exemption request will preclude any person from recommending, or the Commission from requiring, the submission of additional information before finding the Certificate of Need application substantially complete. Moreover, no finding that an application is substantially complete, with or without additional information, would preclude the development of additional information through discovery. Ultimately the burden of proving need for the proposed facility lies with the applicant. The exemptions granted here relate to filing requirements only; they are not findings that the information at issue may not prove essential to

finding need. Such substantive findings would require careful examination of the merits of the application<sup>2</sup>.

In summary, the exemptions the Applicant requests in its Exemption Petition relate to filing requirements only; the burden of proving the claimed need for the proposed Project remains with the Applicant.

In addition, another criterion for exemption request approval is a showing that “the data requirement is unnecessary to determine the need for the proposed facility or may be satisfied by submitting another document” as discussed above. Some of the exemptions requested by GRE are similar to exemption requests granted by the Commission in the past.<sup>3</sup> With all of the above understanding, the Department examines below each specific exemption request separately.

### C. ANALYSIS OF EXEMPTION REQUESTS

#### 1. Minnesota Rules 7849.0260, subp. A(3) and C(6)

These rules require an applicant to provide estimated “losses under projected maximum loading and under projected average loading in the length of the transmission line and at the terminals or substations.” GRE proposed to supply system loss information in lieu of line-specific losses for the Project and other transmission options considered.

In this proceeding, the Department agrees that line losses for the system are more relevant to the analysis than line losses for individual lines. The Department notes that, to make the proper decisions in a societal framework, it is necessary to know what happens to system losses when a line is added. To count only the losses on the line in question might lead to the selection of an alternative because of its lower losses in spite of the potentially higher system line losses; therefore selection of such an alternative would force the system to produce more energy than some other alternative. Thus, the proposal to provide line loss data for the system as a whole is appropriate in this proceeding.

---

<sup>2</sup> *In the Matter of the Application by Koch refining Company for Certification of the Pine Bend Cogeneration Project*, Docket No. IP-2/CN-95-1406 ORDER GRANTING EXEMPTIONS FROM FILING REQUIREMENTS (February 16, 1996); *In the Matter of the Application of Rapids Power LLC for a Certificate of Need for its Grand Rapids Cogeneration Project*, Docket No. IP-4/CN-01-1306 ORDER GRANTING EXEMPTIONS FROM FILING REQUIREMENTS, PERMITTING EXPEDITED FILING, AND EXTENDING PERIOD TO DETERMINE ADEQUACY OF FILING (October 9, 2001) at 3-4; *In the Matter of the Application of Great River Energy for a Certificate of Need for a High Voltage Transmission Line*, Docket No. ET-2/CN-02-536 ORDER GRANTING AND DENYING EXEMPTION REQUESTS AND CLARIFYING FILING REQUIREMENTS (July 2, 2002) at 7; *In the Matter of the Application of Northern States Power Company d/b/a Xcel Energy and Dairyland Power Cooperative for a Certificate of Need for a High Voltage Transmission Line*, Docket No. ET-3, E-002/CN-02-2052, ORDER GRANTING EXEMPTION IN PART AND REQUIRING SUPPLEMENTARY FILING AND NOTICE (April 8, 2003) at 8.

<sup>3</sup> See for example, Docket Nos. ET2/CN-02-536; E002/CN-06-154; ET2,E002/CN-06-1115; E017/CN-06-677; ET2/CN-06-367; E017, E015/CN-07-1222; E002/CN-08-992; ET2,E015/CN-10-973, E002/CN-11-332; and E002/CN-11-826.

In summary, the Department recommends that the Commission approve GRE's proposed exemption to Minnesota Rules 7849.0260 A(3) and C(6), substituting the proposed alternative data.

2. *Minnesota Rules 7849.0270, subps. 1 and 2*

These rules require an applicant to provide information regarding its system peak demand, annual energy consumption, and load factors for the applicant's service area and system. According to GRE, this exemption was requested because the proposed facility is designed to provide improved system reliability for GRE's member cooperative customers (Minnesota Valley Electric Cooperative and Steele-Waseca Cooperative Electric) in the affected load area, rather than for the Applicant's entire system. Instead, GRE proposed to provide data required by Minn. Rules 7849.0270 for the affected load area. GRE also stated the following:

Great River Energy proposes to provide historic demand data for the customers served out of the Gifford Lake, Merriam Junction, Assumption, Belle Plaine, Sand Creek, New Prague, French Lake (SW), Elko, New Market, Spring Lake, Cleary Lake, Prior Lake North and South, and Burnscott substations. The peak demand forecast will be based on the historic loading by substation, and growth rates of the affected load area that is part of the Minnesota Valley Electric Cooperative and Steele Waseca Cooperative Electric systems.

The Department agrees that the submission of data customized to the area of claimed need, in this case data for the affected load area, is appropriate. Information specific to the local area is more relevant to the claimed need than system-wide information.

However, as referenced above, the Department notes that the claimed need for the Project was based on two of its transmission studies, namely its most recent annual Transmission System Assessment Study (TSA study) and the detailed study known as the New Prague Area Study (NPA study) as well as the thermal overload concerns in its Cleary-Elko transmission system. One of the concerns identified for the Cleary-Elko transmission system is the Cleary Lake Tap – Credit River Tap 69 kV transmission line (also known as the “MV – CR” line) as described above.

According to GRE, the Credit River Distribution Substation (part of the “MV-CR” line) is owned by Northern States Power Company d/b/a Xcel Energy. Clearly more than just cooperative-owned detailed substation-specific level data is relevant to this proceeding. As a result:

- GRE should identify all the cooperative-owned and non-cooperative-owned (distribution and transmission) substations in its Cleary-Elko system, and in its TSA and NPA studies referenced above, that are relevant to GRE's proposed Project; and
- GRE should provide all of the relevant data at the cooperative-owned and non-cooperative-owned detailed substation-specific level.

Therefore, the Department recommends that the Commission approve GRE's proposed exemption to Minnesota Rules 7849.0270, subps. 1 and 2 to allow GRE to provide the proposed alternative data as modified above to include relevant non-cooperative-owned substation-specific data.

3. *Minnesota Rules 7849.0270, subps. 2(B) and 2 (C)*

These rules require an applicant to provide information regarding system consumption by customer class for each of the forecast years. GRE requested this exemption since:

... These application requirements were crafted in contemplation of utilities proposing a transmission line to connect to a specific new source of electricity to a specific new source of demand. This is not the basis of the current proposal and these customer class categories have no direct bearing on the need for the Project. Further, providing such data by customer class is not material to establishing the need for a transmission line, as transmission needs are based on aggregate customer demand regardless of the consumption of a particular customer class. The proposed methodology of using historic loading and system forecast growth rates does not require the breakout of the customers by class in the affected load area.

This exemption request has been granted previously on the grounds that the marginal benefit of the data does not justify the effort required to gather it.<sup>4</sup>

The Department agrees that it is the aggregate demand that will be used to evaluate the claimed need. The Department notes that the data GRE proposed to provide, "historic loading and the system forecast growth rates" in the affected load area may be the appropriate data to evaluate GRE's claimed need. However, as was discussed in Section II.C.2 above, the affected load area appears to encompass both cooperative-owned and non-cooperative-owned facilities. Therefore, the Department recommends that the substitute data proposed to be provided by GRE reflect the fact that the "affected load area" may include the relevant non-cooperative-owned facilities.

In summary, the Department recommends that the Commission approve GRE's proposed exemption to Minnesota Rules 7849.0270, subp. 2 (B and C), substituting the proposed alternative data as modified above.

---

<sup>4</sup> *In the Matter of the Otter Tail Power Company Application for a Certificate of Need for a 115 kV Transmission Line Between Appleton and Canby Substations, ORDER GRANTING EXEMPTIONS AND APPROVING NOTICE PLAN AS MODIFIED, Docket No. E-017/CN-06-677 (Aug 1, 2006).*

4. *Minnesota Rules 7849.0270, subp. 2(C)*

This rule requires the applicant to provide information that provides an estimate of the demand for power in the applicant's system at the time of annual system peak demand. GRE stated, in part, the following:

... Additionally, Great River Energy requests that information be provided only for the affected load area and, because this is a transmission project, be provided on an annual coincident peak basis, rather than on an annual peak basis. The Project must provide sufficient transmission capacity within the affected load area based on the maximum demand in the affected load area. Great River Energy's evaluation of the transmission capacity for the Project is based on the annual coincident peak of the affected load area rather than the annual peak demand on our overall system.

As mentioned above, the Department will evaluate the claimed need using aggregate demand. The Department agrees that providing aggregate demand data on an annual coincident peak basis for the affected load area is reasonable. However, as was discussed in Section II.C.2 above, the affected load area appears to encompass both cooperative-owned and non-cooperative-owned facilities. Therefore, the Department recommends that the substitute data proposed to be provided by GRE reflect the fact that the "affected load area" may include the relevant non-cooperative load.

In summary, the Department recommends that the Commission approve GRE's proposed exemption to Minnesota Rules 7849.0270, subp. 2 (C) to allow GRE to provide the proposed alternative data as modified to include the relevant non-cooperative load.

5. *Minnesota Rules 7849.0270, subp. 2(D)*

This rule requires the applicant to provide information on the applicant's system peak demand by month. GRE stated, in part, the following:

...Instead of the information called for in this rule, Great River Energy proposes to provide information on the reliability risks faced by providing demand projections for the cooperative owned substations within the affected load area. This data will demonstrate when overall power demand in the affected load area exceeds the transmission system's capacity. Great River Energy also proposes to describe how the substation demand forecasts were prepared. For each cooperative-owned distribution substation within the affected load area, we propose to provide historical summer and winter peak power demand data and a forecast of power demand at each substation. The sum of demand data from the substations in the affected load area can be compared to the

power delivery capacity of the transmission system to determine the service reliability need. If the system has adequate capacity under peak conditions, in most circumstances, it can operate reliably during periods of lower demand.

Great River Energy's request for an exemption to the requirements of Rule 7849.0270, Subpart 2(D) and to substitute substation data is consistent with prior Commission orders.<sup>5</sup>

The Department agrees that providing the detailed substation-specific level of data, as modified above is the appropriate data needed to address the reliability and claimed need of the Project. However, as is discussed above, the affected load area appears to encompass both cooperative-owned and non-cooperative-owned facilities. Therefore, the Department recommends that the substitute data proposed to be provided by GRE reflect the fact that the "affected load area" may include the relevant non-cooperative load.

In summary, the Department recommends that the Commission approve GRE's proposed exemption to Minnesota Rules 7849.0270, subp. 2 (D), substituting the proposed alternative data as modified above.

6. *Minnesota Rules 7849.0270, subp. 2(E)*

This rule requires the applicant to provide information that provides an estimate of the annual revenue requirement per kilowatt-hour, in current dollars, for each utility's system for each forecast year. In support of this exemption request, the Applicant stated that:

Instead, Great River Energy proposes to provide an explanation of how wholesale electricity costs are spread among users of the transmission grid and the general financial effect of the Project on Great River Energy's cooperatives. The Commission has previously granted a similar request.<sup>6</sup>

---

<sup>5</sup>*In the Matter of the Application of Northern States Power Company d/b/a Xcel Energy for a Certificate of Need for the Upgrade of the Southwest Twin Cities Bluff Creek – Westgate Area 69 kV Transmission Line to 115 kV Capacity*, ORDER GRANTING APPLICANT'S EXEMPTION REQUEST, Docket No. E002/CN-11-332 (Nov. 16, 2011); *In the Matter of the Application of Northern States Power Company d/b/a Xcel Energy and Great River Energy for a Certificate of Need for the Upgrade of the Southwest Twin Cities (SWTC) Chaska Area 69 kV Transmission Line to 115 kV Capacity*, ORDER GRANTING APPLICANTS' EXEMPTION REQUEST, Docket No. E002/CN-11-826 (Nov. 4, 2011); *In the Matter of the Application of Northern States Power, a Minnesota Corporation for Certificates of Need for Two 161 kV Transmission Lines in the Greater Rochester Area*, ORDER APPROVING EXEMPTION REQUEST AS MODIFIED, Docket No. E002/CN-08-992 (Dec. 16, 2008); *In the Matter of The Otter Tail Power Company Application for a Certificate of Need for a 115 kV Transmission Line Between Appleton and Canby Substations*, ORDER GRANTING EXEMPTIONS AND APPROVING NOTICE PLAN AS MODIFIED, Docket No. E-017/CN-06-677 (Aug. 1, 2006).

<sup>6</sup> *In the Matter of the Application of Great River Energy and Minnesota Power for a Certificate of Need for a 115 kV High Voltage Transmission Line in St Louis and Carlton Counties*, ORDER GRANTING EXEMPTION REQUEST, Docket No. E002/CN-10-973 (Nov. 2, 2010).

The Department agrees with the Applicant that the information proposed to be provided is more relevant to the Commission's need decision than the revenue requirement information required by rule. As a result, the Department recommends that the Commission grant GRE's request.

7. *Minnesota Rules 7849.0270, subp. 2(F)*

Minnesota Rules 7849.0270, subp. 2(F) requires average system weekday load factors for each month. The Applicant stated that an exemption is necessary because load factor is not relevant when evaluating the need for a transmission facility. The Department agrees with GRE's assessment and recommends that the Commission grant GRE's request.

8. *Minnesota Rules 7849.0270, subp. 3 - 5*

This rule requires the applicant to provide information on the forecast methodology employed, identification of databases, and details on the assumptions made in preparing the forecasts provided under Minn. Rule 7849.0270, subp. 2. The Applicant supported its request for an exemption to this application content requirement by stating, in part, the following:

... As discussed above, the Project is not prompted by electrical consumption. Instead, the need is prompted by growing consumer demand during peak times. Instead of providing consumption forecasts, Great River Energy believes that providing substation load forecasts and line operation data will better enable an evaluation of the proposed Project.

Similar exemption requests have been granted by the Commission.<sup>7</sup> With these proposed substitute data, the Commission can evaluate the proposal based on information tailored to the affected load area to determine whether the Project is needed to maintain reliable service in the affected load area.

The Department agrees that providing information regarding substation forecast methodology, databases, and assumptions for the affected load area, including relevant non-cooperative data, is appropriate. Information specific to the local area is more relevant to the claimed need than system-wide information. However, as is discussed above, the affected load area appears to encompass both cooperative-owned and non-cooperative-owned facilities. Therefore, the Department recommends that the substitute data proposed to be provided by GRE reflect the fact that the "affected load area" may include the relevant non-cooperative load.

---

<sup>7</sup> See *In the Matter of the Application of Northern States Power Company d/b/a Xcel Energy and Great River Energy for a Certificate of Need for the Upgrade of the Southwest Twin Cities (SWTC) Chaska Area 69 kV Transmission Line to 115 kV Capacity*, ORDER GRANTING APPLICANTS' EXEMPTION REQUEST, Docket No. E002/CN-11-826 (Nov. 4, 2011).

In summary, the Department recommends that the Commission approve GRE's proposed exemption to Minnesota Rules 7849.0270 subps. 3-5, substituting the proposed alternative data as modified above.

9. *Minnesota Rules 7849.0280*

This rule requires the applicant to provide information that describes the ability of its existing system to meet forecasted demand; in essence, load and capability (L&C) information. The Applicant requested confirmation that the requirements of Minn. Rules 7849.0280 as applied to transmission facilities are satisfied using data and information that relates back to Minnesota Rules 7849.0270. The Department agrees with GRE that the Applicant's proposed discussion, focusing on transmission adequacy, is more relevant than the required data, which focuses on generation adequacy. The Commission has noted in the past that much of Minn. Rule 7849.0280 pertains to electric generators.<sup>8</sup> The Applicant requested an exemption from the requirements of paragraphs B through G and I as those sections apply to generators and not transmission proposals. The Applicant suggested that the remaining requirements of Minn. Rule 7849.0280, subps. A and H, are relevant to this proceeding and would be satisfied by providing information related to the affected load area for the Project.

The Department recommends that the Commission grant GRE's exemption request with the provision of the proposed alternative data, as modified above to include relevant non-cooperative load data.

10. *Minnesota Rules 7849.0290*

This rule requires the applicant to provide conservation program information and quantification of the impact of conservation programs on forecast data. Instead GRE proposed to submit:

Great River Energy requests confirmation that the information required by Minnesota Rule 7849.0290 on conservation and efficiency programs should be provided on a load center basis. These rule provisions require an application for a Certificate of Need to provide analyses of how existing and anticipated conservation programs affect forecasted demand and the need for the proposed facility. Because the need for the Project is based on the demand within the affected load area, information concerning conservation and efficiency programs should focus on those programs available to our cooperatives that serve customers in the affected load area. Impacts of the conservation improvement programs are assumed to be in proportion to the amount of load in the affected load area.

---

<sup>8</sup> See for example, Docket Nos. ET-2, E002/CN-06-1115; E017, E015/CN-07-1222; and ET2, E015/CN-10-973.



This is supported by Minnesota Rule 7849.0290, Subpart F, which requires that an application for a Certificate of Need include “quantification of the manner by which [conservation and efficiency] programs affect or help determine the forecast provided in response to part 7849.0270, subpart 2,” for which Great River Energy has also requested an exemption. Therefore, the referenced forecast should be determined on a load center basis. The Commission has granted similar requests related to conservation information.<sup>9</sup>

As with section II C 2 through 8 above (forecast data), the Department notes that the data GRE proposed to provide is appropriate data regarding the claimed need to address reliability in the affected load area as modified to include relevant non-cooperative data. Therefore, the Department recommends that the Commission grant the exemption with the provision of the proposed alternative data as modified above.

*11. Minnesota Rules 7849.0300 and 7849.0340*

Minnesota Rules 7849.0300 requires detailed information regarding the consequences of delay on three specific statistically based levels of demand and energy consumption. Minnesota Rules 7849.0340 requires a discussion of what the impact would be on existing generation and transmission facilities at three levels of demand specified in part 7849.0300 for the no-build alternative. GRE stated that it fully intends to discuss issues related to delay of the facility.

The Applicant also stated the following:

... Great River Energy fully intends to discuss issues of delay and variations in actual demand from forecast. There is one specific requirement, however, that we request the Commission vary: the rule requires that the examination of delay incorporate three specific statistically based levels of demand. Minnesota Rule 7849.0340 requires a discussion of the alternative of “no facility” and requires that analysis using the same three levels of demand.

---

<sup>9</sup> *In the Matter of the Application of Northern States Power Company d/b/a Xcel Energy and Great River Energy for a Certificate of Need for the Upgrade of the Southwest Twin Cities (SWTC) Chaska Area 69 kV Transmission Line to 115 kV Capacity, ORDER GRANTING APPLICANTS’ EXEMPTION REQUEST, Docket No. E002/CN 11-826 (Nov. 4, 2011); In the Matter of the Application of Great River Energy and Minnesota Power for a Certificate of Need for a 115 KV High Voltage Transmission Line in St Louis and Carlton Counties, ORDER APPROVING EXEMPTIONS AND PROPOSED PROVISION OF ALTERNATIVE DATA, Docket No. E002/CN-10- 973 (Nov. 2, 2010); In The Matter of The Application of Northern States Power, a Minnesota Corporation for Certificates OF Need For Two 161 kV Transmission Lines in the Greater Rochester Area, ORDER APPROVING EXEMPTION REQUEST AS MODIFIED, Docket No. E002/CN-08-992 (Dec. 16, 2008); In the Matter of the Application for Certificates of Need for Three 115 kV Transmission Lines in Southwestern Minnesota, Order Granting Exemptions, Docket No. E-002/CN-06-154 (June 24, 2006).*

We propose to evaluate the consequences of delay and the no build alternative based on potential impacts to community service reliability in the affected load area. There is a threshold peak demand level at which service to an area is at risk. Once that peak demand level is surpassed, variations in growth alter the amount of time that service is at risk. Great River Energy proposes to identify the threshold level of demand that places service at risk and the effect of incremental change in growth rather than evaluate system performance at three discrete demand levels.

We believe that this information will fully support our Application and better inform the analysis performed by the Commission.

The Department agrees with GRE that the Applicant's proposed data, focusing on demand in the local area, is relevant to the claimed need and, in this case, would provide better information than the required data. Therefore, the Department recommends that the Commission grant the exemption and allow GRE to provide the proposed alternative data.

### **III. DEPARTMENT RECOMMENDATION**

The Department concludes that the Applicant bears the burden of proving the claimed need for the proposed project. The exemptions requested relate to filing requirements only. The burden of proving the claimed need for the proposed transmission lines and associated facilities remains with GRE.

The Department recommends that the Commission approve the Applicant's request for exemptions from the required data with the provision of the proposed alternative data as modified above.

/ja

# **APPENDIX C**

## **Certificate of Need Application Requirements Completeness Checklist**

**THIS PAGE INTENTIONALLY BLANK**

## Certificate of Need Application Completeness Checklist

Authority	Required Information	Location in Application
Minn. R. 7849.0120 A	Showing that denial would adversely affect adequacy, reliability and efficiency	
1	Demand forecast for type of energy supplied by proposed facility is accurate	§ 5.6
2	Effects of Applicants' conservation program and state and federal conservation programs	§ 5.8; Appendix I
3	Effects of Applicants' promotional practices on energy demand	§ 5.10
4	Ability of current facilities and facilities not requiring CON to meet future demand	§§ 5.1; 6.4.1
5	Effect of proposed facility in making efficient use of resources	§§ 4.1; 5.7
Minn. R. 7849.0120 B	A more reasonable and prudent alternative has not been demonstrated	
1	Facility is appropriate size, type and timing compared to reasonable alternatives	§ 4.1; Chapter 6
2	Cost of facility and of its energy compared to reasonable alternatives	§ 4.2; Chapter 6; Appendix H
3	Effects of the proposed facility upon the natural and socio-economic environment compared to the effects of reasonable alternatives	Chapters 6 and 9
4	Expected reliability of facility compared to reasonable alternatives	§ 4.1; Chapter 6
Minn. R. 7849.0120 C	Project will provide benefit to society:	
1	Relationship of facility to overall state energy needs	§ 5.2
2	Effects of facility on natural and socio-economic environment compared to not building facility	§ 6.10; Chapter 9
3	Effects of facility inducing future development	§§ 5.1; 8.1.2
4	Socially beneficial uses of the output of the facility, including its uses to protect or enhance environmental quality	§ 5.1; Chapter 9
Minn. R. 7849.0120 D	Project will comply with relevant policies and regulations of other state and federal agencies and local governments	§§ 2.5; 4.6; 8.4; Chapter 9
Minn. R. 7849.0200, Subp. 2	Title Page	Title Page

Authority	Required Information	Location in Application
Minn. R. 7849.0200, Subp. 2	Table of Contents	Pages i – viii
Minn. R. 7849.0200, Subp. 4	Cover Letter	Cover Letter
7849.0210	Filing Fee	Cover Letter
Minn. R. 7849.0220, Subp. 3	Joint Ownership and Multiparty Use	§ 3.1
Minn. R. 7849.0230	Draft Environmental Report	Not required
Minn. R. 7849.0240	Need Summary and Additional Considerations	
Minn. R. 7849.0240, Subp. 1	Major factors that justify need for facility	5.1
Minn. R. 7849.0240, Subp. 2(A)	Socially beneficial uses of facility output, including uses to protect or enhance environmental quality	§ 5.1; Chapter 9
Minn. R. 7849.0240, Subp. 2(B)	Promotional activities that may have given rise to demand	§ 5.10
Minn. R. 7849.0240, Subp. 2(C)	Effects of the facility in inducing future development	§§ 5.1; 8.1.2
Minn. R. 7849.0260	Proposed LHVTL and Alternatives	
Minn. R. 7849.0260 A	Type and location of proposed line, including:	
1	Design voltage	§ 4.1
2	Number, sizes and types of conductors	§ 4.1
3	Expected losses under maximum and average loading in lines and terminals or substations <i>Exemption: Provide total system losses.</i>	§ 4.5

Authority	Required Information	Location in Application
4	Length of line and portion in Minnesota	§ 4.1
5	Location of DC terminals or AC substations on map	§ 4.1; Figures 1-2 and 1-3; Appendix G
6	List of counties affected by construction and operation	§ 4.1
Minn. R. 7849.0260 B	Availability of alternatives, including:	
1	New generation of various technologies, sizes, fuel types	§ 6.2
2	Upgrade of existing lines or generating facilities	§ 6.3
3	Transmission with different voltages or conductor arrays	§§ 6.4; 6.5
4	Transmission lines with different terminals or substations	§ 6.6
5	Double circuiting of existing transmission lines	§ 6.7
6	If facility for DC (AC) transmission, an AC (DC) transmission line	§ 6.8
7	If facility for overhead (underground) transmission, an underground (overhead) transmission line	§ 6.9
8	Any reasonable combination of alternatives (1) – (7)	Chapter 6
Minn. R. 7849.0260 C	For facility and for each alternative, discuss:	
1	Total cost in current dollars	§ 4.2; Chapter 6; Appendix H
2	Service life	§ 4.1.1; Chapter 6
3	Estimated average annual availability	§ 4.1.1; Chapter 6
4	Estimated annual operating and maintenance costs in current dollars	§§ 4.2.2; 8.6; Chapter 6
5	Estimate of its effect on rates system-wide and in Minnesota	§ 4.3
6	Efficiency Exemption: <i>Provide system totals.</i>	§§ 4.5; 5.7; Chapter 6
7	Major assumptions made in sub items (1) – (6)	See above
Minn. R. 7849.0260 D	Scaled map showing the system or load center to be served	Figures 1-2; 1-3; 3-1
Minn. R. 7849.0260 E	Any other relevant information about the proposed facility and each alternative	Seriatim
Minn. R. 7849.0270	Content of Forecast	
Minn. R. 7849.0270, Subp. 1	Pertinent data concerning peak demand and annual electrical consumption Exemption: <i>Provide cooperative-owned and non-cooperative-owned substation data.</i>	§ 5.5

Authority	Required Information	Location in Application
Minn. R. 7849.0270, Subp. 2	Forecast data Exemption: <i>Provide cooperative-owned and non-cooperative-owned substation data.</i>	§ 5.6; Appendix H
Minn. R. 7849.0270, Subp. 3	Detail of the forecast methodology employed in Subp.2 Exemption: <i>Provide cooperative and non-cooperative load.</i>	§ 5.6.1
Minn. R. 7849.0270, Subp. 4	Discussion of the data base used in current forecasting Exemption: <i>Provide cooperative and non-cooperative load.</i>	§ 5.6
Minn. R. 7849.0270, Subp. 5	Discussion of assumptions made in forecast preparation Exemption: <i>Provide cooperative and non-cooperative load.</i>	§ 5.6
Minn. R. 7849.0270, Subp. 6	Coordination of forecasts	§ 5.6; Appendix H
Minn. R. 7849.0280	Description of system capacity Exemption: <i>Provide cooperative and non-cooperative load.</i>	§ 5.6; Appendix H
Minn. R. 7849.0290	Conservation Programs	§ 5.8; Appendix I
Minn. R. 7849.0300	Consequences of delay Exemption: <i>Threshold peak demand.</i>	§ 5.9
Minn. R. 7849.0310	Environmental Information	Chapter 9; Appendices G & K
Minn. R. 7849.0330	Provide data for each alternative that would require LHVTL construction	§ 4.1.1; Chapter 6; Chapters 8 and 9
Minn. R. 7849.0340	No-Facility Alternative Exemption: <i>Threshold peak demand.</i>	§§ 5.9; 6.10
Minn. R. 7849.0340 C	Description of possible methods of reducing environmental impact	Chapter 9
Minn. R. 7829.2500, Subp. 2	Single Page Summary for Interested Parties	Filing Summary



# **APPENDIX D**

## **Notice of Intent to File Under Alternative Permitting Process**

**THIS PAGE INTENTIONALLY BLANK**



GREAT RIVER  
ENERGY®

12300 Elm Creek Boulevard • Maple Grove, Minnesota 55369-4718 • 763-445-5000 • Fax 763-445-5050 • www.GreatRiverEnergy.com

22 May 2013

Dr. Burl W. Haar  
Executive Secretary  
Minnesota Public Utilities Commission  
121 7<sup>th</sup> Place East, Suite 350  
St. Paul, MN 55101

**RE: Notice of Intent by Great River Energy to Submit a Route Permit  
Application under the Alternative Permitting Process  
ET2/TL-12-1245**

Dear Dr. Haar:

Pursuant to Minn. Rules 7850.2800, subp. 2, this letter serves as notice to the Minnesota Public Utilities Commission (Commission) that Great River Energy intends to submit a Route Permit application for the Elko New Market and Cleary Lake Areas 115 kV Transmission Project in Scott and Rice counties, Minnesota under the Alternative Permitting processes of Minn. Rules 7850.2800 to 7850.3900.

Great River Energy intends to submit a combined Certificate of Need/Route Permit application to the Commission in June 2013. The Commission has assigned Docket No. ET2/CN-12-1235 to the Certificate of Need proceeding.

Please feel free to call me at 763-445-5214 if you have any questions regarding this notice.

Sincerely,

GREAT RIVER ENERGY

Carole L. Schmidt  
Supervisor, Transmission Permitting and Compliance

c: Deborah Pile, EFP

s:\legal\environmental\transmission\projects\201719 New Market Area Project\ENMPUCnotltr

**THIS PAGE INTENTIONALLY BLANK**

# **APPENDIX E**

## **Route Permit Application Requirements Completeness Checklist**

**THIS PAGE INTENTIONALLY BLANK**

## Route Permit Application – Alternative Process Completeness Checklist

Authority	Required Information	Location in Application
Minn. Stat. § 216E.04, subd. 2(3)	<b>Alternative Review of Applications.</b> Alternative review is available for high voltage transmission lines of between 100 and 200 kV	§ 2.2
Minn. Stat. § 216E.04, subd. 4; Minn. R. 7850.2800, Subp. 1(C)	Subpart 1. <b>Eligible Projects.</b> An applicant for a site permit or a route permit for one of the following projects may elect to follow the procedures of parts 7850.2800 to 7850.3900 instead of the full permitting procedures in parts 7850.1700 to 7850.2700: <b>high voltage transmission lines of between 100 and 200 kilovolts</b>	Appendix D
Minn. R. 7850.2800, Subp. 2.	Subpart 2. <b>Notice to PUC.</b> An applicant for a permit for one of the qualifying projects in subpart 1, who intends to follow the procedures of parts 7850.2800 to 7850.3700, shall notify the PUC of such intent, in writing, at least ten days before submitting an application for the project	Appendix D
Minn. R. 7850.3100	<b>Contents of Application</b> (alternative permitting process) The applicant shall include in the application the same information required in part 7850.1900, except the applicant need not propose any alternative sites or routes to the preferred site or route. If the applicant has rejected alternative sites or routes, the applicant shall include in the application the identity of the rejected sites or routes and an explanation of the reasons for rejecting them	This document.
Minn. R. 7850.1900, Subp. 2 (applicable per Minn. R. 7850.3100)	<b>Route Permit for HVTL</b> A. a statement of proposed ownership of the facility at the time of filing the application and after commercial operation	§ 3.1
	B. the precise name of any person or organization to be initially named as permittee or permittees and the name of any other person to whom the permit may be transferred if transfer of the permit is contemplated	§ 3.1
	C. rejected alternative routes and the reasons for rejecting	§ 7.2
	D. a description of the proposed high voltage transmission line and all associated facilities including the size and type of the high voltage transmission line	§ 4.1
	E. the environmental information required under 7850.1900, Subp. 3	Chapter 9
	F. identification of land uses and environmental conditions along the proposed routes	§§ 9.1; 9.8
	G. the names of each owner whose property is within any of the proposed routes for the high voltage transmission line	Appendix J
	H. United States Geological Survey topographical maps or other maps acceptable to the chair showing the entire length of the high voltage transmission line on all proposed routes	Figure 1-2; Appendix G

Authority	Required Information	Location in Application
	I. identification of existing utility and public rights-of-way along or parallel to the proposed routes that have the potential to share right-of-way with the proposed line	§ 8.2
	J. the engineering and operational design concepts for the proposed high voltage transmission line, including information on the electric and magnetic fields of the transmission line	§§ 4.1; 8.7
	K. cost analysis of each route, including the costs of constructing, operating, and maintaining the high voltage transmission line that are dependent on design and route	§ 4.2
	L. a description of possible design options to accommodate expansion of the high voltage transmission line in the future	§ 8.1.2
	M. the procedures and practices proposed for the acquisition and restoration of the right-of-way, construction, and maintenance of the high voltage transmission line	§§ 8.3; 8.4; 8.5; 8.6
	N. a listing and brief description of federal, state, and local permits that may be required for the proposed high voltage transmission line	§ 2.5; Table 2-1
	O. a copy of the Certificate of Need or the certified HVTL list containing the proposed high voltage transmission line or documentation that an application for a Certificate of Need has been submitted or is not required	This document
Minn. R. 7850.1900, Subp. 3	<b>Environmental Information</b> A. a description of the environmental setting for each site or route	§ 9.1
	B. a description of the effects of construction and operation of the facility on human settlement, including, but not limited to, public health and safety, displacement, noise, aesthetics, socioeconomic impacts, cultural values, recreation, and public services	§ 9.2
	C. a description of the effects of the facility on land-based economies, including, but not limited to, agriculture, forestry, tourism, and mining	§ 9.3
	D. a description of the effects of the facility on archaeological and historic resources	§ 9.4
	E. a description of the effects of the facility on the natural environment, including effects on air and water quality resources and flora and fauna	§ 9.5
	F. a description of the effects of the facility on rare and unique natural resources	§ 9.6
	G. identification of human and natural environmental effects that cannot be avoided if the facility is approved at a specific site or route	Chapter 9
	H. a description of measures that might be implemented to mitigate the potential human and environmental impacts identified in items A to G and the estimated costs of such mitigative measures	Chapter 9



Authority	Required Information	Location in Application
Minn. R. 7850.2100, Subp. 2 (applicable per Minn. R. 7850.3300)	<b>Notice of Project</b> Notification to persons on PUC's general list, to local officials, and to property owners	To be provided
Minn. R. 7850.2100, Subp 4	Publication of notice in a legal newspaper of general circulation in each county in which the route is proposed to be located.	To be published
Minn. R. 7850.2100, Subp. 5	Confirmation of notice by affidavits of mailing and publication with copies of the notices	Submit when available
Minn. R. 7850.4100	<b>Factors to be Considered in Permitting a HVTL</b> A. effects on human settlement, including, but not limited to, displacement, noise, aesthetics, cultural values, recreation, and public services	§ 9.2
	B. effects on public health and safety	§ 9.2
	C. effects on land-based economies, including, but not limited to, agriculture, forestry, tourism, and mining	§ 9.3
	D. effects on archaeological and historic resources	§ 9.4
	E. effects on the natural environment, including effects on air and water quality resources and flora and fauna	§ 9.5
	F. effects on rare and unique natural resources	§ 9.6
	G. application of design options that maximize energy efficiencies, mitigate adverse environmental effects, and could accommodate expansion of transmission or generating capacity	§§ 4.1; 8.1.2
	H. use or paralleling of existing rights-of-way, survey lines, natural division lines, and agricultural field boundaries	§§ 4.1; 8.2
	I. use of existing large electric power generating plant sites	Not applicable
	J. use of existing transportation, pipeline, and electrical transmission systems or rights-of-way	§ 8.2
	K. electrical system reliability	§§ 5.1; 5.9
	L. costs of constructing, operating, and maintaining the facility which are dependent on design and route	§ 4.2
	M. adverse human and natural environmental effects which cannot be avoided	Chapter 9
	N. irreversible and irretrievable commitments of resources	§ 9.9
Minn. R. 7850.4300, Subps. 1 and 2	Prohibited Routes <b>Wilderness areas.</b> No high voltage transmission line may be routed through state or national wilderness areas <b>Parks and natural areas.</b> No high voltage transmission line may be routed through state or national parks or state scientific and natural areas unless the transmission line would not materially damage or impair the purpose for which the area was designated and no feasible and prudent alternative exists. Economic considerations alone do not justify use of these areas for a high voltage transmission line	No wilderness areas or parks are crossed

Authority	Required Information	Location in Application
Minn. Stat. §216E.03, Subd.7 (applicable per Minn. Stat. §216E.04, Subd. 8)	<b>Considerations in designating sites and routes</b> (1) Evaluation of research and investigations relating to the effects on land, water and air resources of large electric power generating plants and high voltage transmission lines and the effects of water and air discharges and electric and magnetic fields resulting from such facilities on public health and welfare, vegetation, animals, materials and aesthetic values, including base line studies, predictive modeling, and evaluation of new or improved methods for minimizing adverse impacts of water and air discharges and other matters pertaining to the effects of power plants on the water and air environment	Chapter 9
	(2) Environmental evaluation of sites and routes proposed for future development and expansion and their relationship to the land, water, air and human resources of the state	§ 8.1.2
	(3) Evaluation of the effects of new electric power generation and transmission technologies and systems related to power plants designed to minimize adverse environmental effects	Not applicable
	(4) Evaluation of the potential for beneficial uses of waste energy from proposed large electric power generating plants	Not Applicable
	(5) Analysis of the direct and indirect economic impact of proposed sites and routes including, but not limited to, productive agricultural land lost or impaired	§ 9.3
	(6) Evaluation of adverse direct and indirect environmental effects that cannot be avoided should the proposed site and route be accepted	Chapter 9
	(7) Evaluation of alternatives to the applicant's proposed site or route proposed pursuant to subdivisions 1 and 2	Chapter 7
	(8) Evaluation of potential routes that would use or parallel existing railroad and highway rights-of way	§ 8.2; Chapter 9
	(9) Evaluation of governmental survey lines and other natural division lines of agricultural land so as to minimize interference with agricultural operations	§§ 8.2; 9.3.1
	(10) Evaluation of the future needs for additional high voltage transmission lines in the same general area as any proposed route, and the advisability of ordering the construction of structures capable of expansion in transmission capacity through multiple circuiting or design modifications	§§ 6.3; 6.6; 8.1.2
	(11) Evaluation of irreversible and irretrievable commitments of resources should the proposed site or route be approved	Chapter 9
	(12) When appropriate, consideration of problems raised by other state and federal agencies and local entities	Not applicable

# **APPENDIX F**

## **Order Approving Notice Plan**

**THIS PAGE INTENTIONALLY BLANK**

BEFORE THE MINNESOTA PUBLIC UTILITIES COMMISSION

Beverly Jones Heydinger  
David C. Boyd  
J. Dennis O'Brien  
Phyllis A. Reha  
Betsy Wergin

Chair  
Commissioner  
Commissioner  
Commissioner  
Commissioner

In the Matter of the Application of Great River Energy for a Certificate of Need for a 115 kV Transmission Line Project in the Elko, New Market, and Cleary Lake Areas in Scott and Rice Counties

ISSUE DATE: February 4, 2013

DOCKET NO. ET-2/CN-12-1235

ORDER MODIFYING AND APPROVING NOTICE PLAN AND EXEMPTION REQUESTS

**PROCEDURAL HISTORY**

On November 9, 2012, Great River Energy (the Applicant) filed a notice plan petition under Minn. Rules, chapter 7849.2550 and a request for exemption from certain data requirements under Minn. Rules 7849.0200. subp. 6, in connection with an anticipated certificate of need application.

The only party to comment on either filing was the Minnesota Department of Commerce (the Department), which recommended granting both petitions with modifications. Great River Energy accepted the Department's recommendations on its exemption request and did not oppose the Department's recommendations on its proposed notice plan.

On January 24, 2013, the Commission met to consider the matter.

**FINDINGS AND CONCLUSIONS**

**I. Proposed Project**

The proposed project is a 115 kV transmission line in the Elko, New Market, and Cleary Lake areas of Scott and Rice counties. The project is a combination of 1) rebuilds and upgrades to approximately 13.6 miles of single and double circuit 69 kV transmission lines to 115 kV; 2) construction of approximately 5.4 miles of new double circuit 115 kV capable transmission lines; and 3) construction of a new 69 kV breaker station. Applicant states that it intends to file its certificate of need application in March 2013.

**II. Proposed Notice Plan**

The Department reviewed the Applicant's proposed notice plan under Minn. Rules, part 7829.2550, subp. 3, which requires an applicant to file a proposed notice plan designed to notify all

persons reasonably likely to be affected by the proposed line. The rule requires such plans to include direct mail notice to landowners, tribal governments, local governments and other governmental entities, as well as to all mailing addresses within the area reasonably likely to be affected by the line.

The rule also requires newspaper notice to members of the public in areas reasonably likely to be affected by the proposed line. The notice must contain information regarding the project, including a map of the proposed line and other existing facilities, as well as a statement that the line cannot be constructed unless the Commission certifies that it is needed.

In its evaluation of the proposed notice plan, the Department recommended that the Commission approve Applicant's proposed notice plan, modified to include the following:

- notice publication in the *Savage Pacer*;
- minor language revisions to the notice content, largely editorial or stylistic;<sup>1</sup> and
- clarification that the "Notice Area" of 1000 feet surrounding the project is satisfactory, as long as the subsequent route permit application is submitted with a request for a lesser route width.

Having considered the Applicant's proposed notice plan, the Commission concurs with the Department that the plan meets the requirements contained in Minn. Rules, part 7829.2550, with the modifications recommended by the Department. Accordingly, the Commission approves the notice plan with the modifications recommended by the Department.

### **III. Rule Variances**

The Applicant requested that the Commission grant a variance to Minn. Rules, part 7829.2500, subp. 5, which requires an applicant to publish a newspaper notice upon filing a certificate of need application, stating that it will publish newspaper notice of the certificate of need filing as part of the notice plan implementation no more than 60 days before its certificate of need application.

The Applicant also requested that the Commission grant a variance to Minn. Rules, part 7829.2550, subp. 6, which requires an applicant to implement the proposed notice plan within 30 days of approval by the Commission. The Applicant has instead requested to implement the notice plan no more than 60 days and no less than two weeks prior to the filing of the certificate of need application to allow the notice to more closely coincide with the certificate of need filing.

Applicant asserts that should the Commission grant a variance to the rules, the two newspaper notices for the notice plan and the certificate of need application could be combined. Applicant states that it would publish newspaper notice of the certificate of need application in newspapers of local and regional circulation up to 60 days before and no less than two weeks prior to the filing of the certificate of need application.

---

<sup>1</sup> The Department's recommendations regarding the minor language revisions are found in Attachment A to this Order.

### **A. Legal Standard for Varying Rules**

Under Minn. Rules, part 7829.3200, the Commission is authorized to vary any of its rules upon making the following findings:

- 1) enforcement of the rule would impose an excessive burden upon the applicant or others affected by the rule;
- 2) granting the variance would not adversely affect the public interest; and
- 3) granting the variance would not conflict with standards imposed by law.

The Department supported varying the rules, stating that enforcement of the rules would burden all parties involved by separating the provision of notice from the start of the proceeding; that enforcement of the rules would not adversely affect the public interest and would better tie the implementation of notice to the beginning of the certificate of need proceeding; and that the Department is not aware that the variances requested would conflict with standards imposed by law.

### **B. Commission Action**

The Commission concurs with the parties and will vary the requirement of Minn. Rules, part 7829.2500, subp. 5 that an applicant publish a separate newspaper notice upon the filing of a certificate of need application, instead authorizing the newspaper notices for the notice plan and certificate of need to be combined. The Commission will also vary the 30-day time line of Minn. Rules, part 7829.2550, subp. 6. In granting these variances, the Commission makes the following findings:

- 1) Enforcing the rules would impose an excessive burden upon the public and upon parties to the proceeding by separating the delivery of the notice from the start of the certificate of need proceeding;
- 2) Granting the variances would not adversely affect the public interest and would in fact serve the public interest since implementation of the notice plan would more closely coincide with the beginning of the certificate of need process; and
- 3) Varying the 30-day time line would not conflict with any other standards imposed by law.

## **IV. Exemption Request**

### **A. In General**

Commission rules list the types of information that might be useful for evaluating the need for a large energy facility, and direct utilities to file this information with their certificate of need applications. But not every type of information listed is relevant or appropriate to every type of large energy facility. Consequently, the rules provide for applicants to seek exemptions from these rules whenever “the data requirement is unnecessary to determine the need for the proposed facility. . . .”<sup>2</sup> In this manner, the certificate of need filing requirements are tailored to the circumstances of each proposal.

---

<sup>2</sup> Minn. Rules, part 7849.0200, subp. 6.

## **B. Applicant's Request**

Applicant requested exemption from providing data requested under the following portions of Minnesota Rules:

- Minnesota Rule 7849.0260, subparts A(3) and C(6) -- Line Losses;
- Minnesota Rule 7849.0270, subparts 1 and 2 --Line Losses;
- Minnesota Rule 7849.0270, subparts 2(B) and 2(C) -- Customer Class Information;
- Minnesota Rule 7849.0270, subpart 2(C) -- Annual Peak Demand –;
- Minnesota Rule 7849.0270, subpart 2(D) -- Monthly Peak Demand;
- Minnesota Rule 7849.0270, subpart 2(E) -- Revenue Requirements –;
- Minnesota Rule 7849.0270, subpart 2(F) -- Weekday Load Factor –;
- Minnesota Rule 7849.0270, subparts 3 through 5 -- Forecast Methodology;
- Minnesota Rule 7849.0280 (A) and (H) -- System Capacity –;
- Minnesota Rule 7849.0280 (B) through (G) and (I) -- System Capacity –;
- Minnesota Rule 7849.0290 -- Conservation;
- Minnesota Rule 7849.0300 -- Consequences of Delay; and
- Minnesota Rule 7849.0340 -- No-Facility Alternative –

Applicant stated that in accordance with Minn. Rules, part 7849.0200, subp. 6, the Commission could grant an exemption from providing certain information as part of a certificate of need application if the applicant requested an exemption in writing that showed that the data requirement was either unnecessary to determine the need for the proposed facility or that the requirement could be satisfied by submitting another document. With respect to each rule from which it seeks exemption, Applicant has undertaken to make such a showing.

## **C. The Department's Comments and Recommendations**

The Department submitted a detailed analysis of each of the Applicant's exemption requests. The Department concluded that the Commission should grant the requested exemptions, but modified the substitute data that Applicant proposed to provide with respect to certain data requirements.

Applicant filed comments agreeing with the Department's recommendations regarding its exemption requests, and agreeing to provide substation-specific level data for both cooperative and non-cooperative owned substations in its certificate of need application.

## **D. Commission Action**

Minnesota Rules 7849.0200, subp. 6 states:

Before submitting an application, a person is exempted from any data requirement of this chapter if the person (1) requests an exemption from specified rules, in writing to the commission and (2) shows that the data requirement is unnecessary to determine the need for the proposed facility or may be satisfied by submitting another document.

The Commission has reviewed the Department's detailed examination of Applicant's exemption requests, and concurs in its analysis, and grants the requests, incorporating the modifications set forth in the Department's December 19, 2012 comments.



## ORDER

1. The Commission approves the proposed notice plan as modified by the Department in its comments, and as reflected in Attachment A hereto.
2. The Commission varies Minn. Rules, part 7829.2500, subp. 5, and permits Applicant to combine publishing the newspaper notices for the notice plan and certificate of need upon filing a certificate of need application.
3. The Commission varies Minn. Rules, part 7829.2550, subp.6, and authorizes Applicant to implement the notice plan no more than 60 days and no less than two weeks prior to the filing of the certificate of need application.
4. The Commission grants the exemption requests, modified to incorporate the Department's proposed modifications to the substitute data proposed by Applicant.
5. This Order shall become effective immediately.

BY ORDER OF THE COMMISSION

Burl W. Haar  
Executive Secretary



This document can be made available in alternative formats (i.e., large print or audio tape) by calling 651.296.0406 (voice). Persons with hearing or speech disabilities may call us through Minnesota Relay at 1.800.627.3529 or by dialing 711.

*Applicant's Proposed Notice Plan, Attachment C (second page, fourth paragraph) and Attachment D (second page, last paragraph)*

In addition to certifying the Project, the Commission must also grant a Route Permit for the Project. The routing of the Project is governed by Minnesota law, including Minnesota Statutes Chapter 216E and Minnesota Rules Chapter 7850, specifically Rules 7850.2900 to 7850.4600, as they pertain to the alternative permitting process. Information on the Route Permit application, once filed, can be obtained by visiting the Department of Commerce Energy Facility Permitting ("EFP") Commission's website in Docket No. ET2/TL-12-\_\_\_ at <http://mn.gov/commerce/energyfacilities/Docket.html?Id=32989>.

*Applicant's Proposed Notice Plan Attachment C (second page, last paragraph) and Attachment D (third page, first paragraph)*

~~Minnesota Department of Commerce Energy Facility Permitting EFP~~ staff ("EFP") is responsible for conducting environmental review of the Project. ~~EFP staff will prepare is~~ responsible for preparing an environmental report ("ER") for the Certificate of Need proceeding. EFP staff will prepare is also responsible for preparing an environmental assessment ("EA") for the Route Permit proceeding. EFP staff may elect to combine these two documents and issue one document, an EA in lieu of an ER, which satisfies the environmental review requirements for the Certificate of Need and Route Permit proceedings.

*Applicant's Proposed Notice Plan Attachment C (fourth page, Department of Commerce contact information), Attachment D (fourth page, Department of Commerce contact information), Attachment H (second page, Department of Commerce contact information)*

Minnesota Department of Commerce

~~Deborah Pile David Birkholz~~, State Permit Manager  
85 7th Place East, Suite 500  
St. Paul, Minnesota 55101  
~~651.297.2375-296.2878~~  
800.657.3794

~~deborah.pile-david.birkholz@state.mn.us~~

*Applicant's Proposed Notice Plan Attachment C (third page, last paragraph) and Attachment D (fifth page, first paragraph), Attachment H (second page, fifth paragraph)*

If you would like to have your name added to the Project Route Permit mailing list (Docket No. ET2/TL-12-\_\_\_ -1245), you may register by visiting the Department of Commerce webpage at [mn.gov/commerce/energyfacilities/](http://mn.gov/commerce/energyfacilities/), clicking on the "Transmission Lines" tab, selecting the link for the 115 kV Transmission Line Project in the Elko New Market and Cleary Lake Areas from the listed projects, and then clicking the links next to the "Mailing List" heading. Alternately, you may contact Department of Commerce staff at the address above. ~~Please be aware that the Route Permit mailing list may not be available for online registration until the Route Permit application is submitted.~~

# **APPENDIX G**

## **Detailed Route Maps**

**THIS PAGE INTENTIONALLY BLANK**

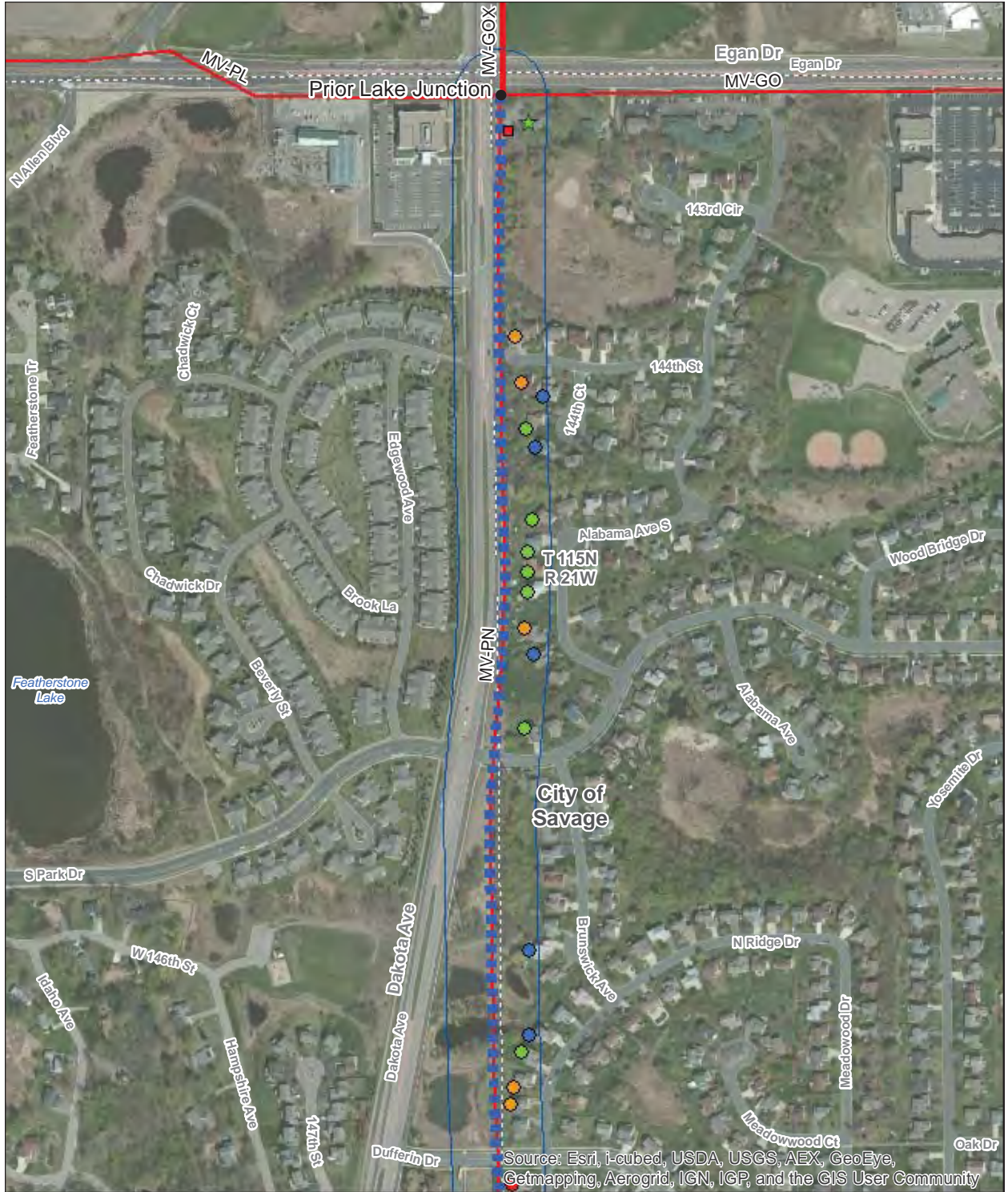

Source: Esri, i-cubed, USDA, USGS, AEX, GeoEye, Getmapping, Aerogrid, IGN, IGP, and the GIS User Community

**Proposed Great River Energy 115 kV Transmission Line**  
 ■ MV-PN North Segment  
 Existing Great River Energy  
 — 69 kV Transmission Line

- Residence
  - Within 150' (5)
  - Within 100' (7)
  - Within 75' (5)
  - Within 50' (1)
- Business
  - ★ Within 100' (1)
- Accessory
  - Within 50' (1)
- 300' route width

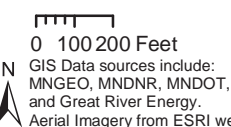

**Elko New Market and Cleary Lake Areas Project**  
**Appendix G**  
**Prior Lake Junction to Credit River Junction**  
**Map Series 1 of 5**



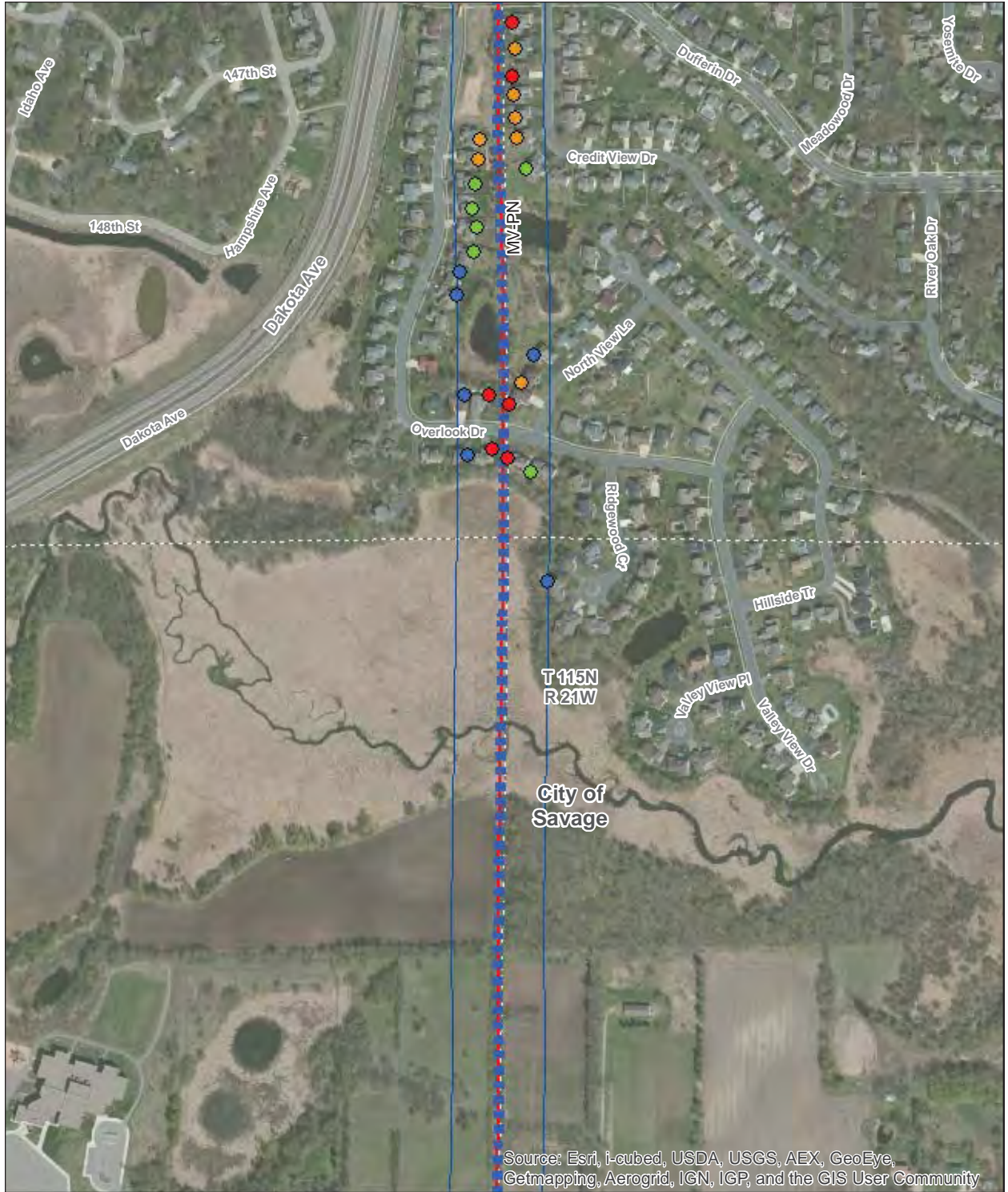

**Proposed Great River Energy  
115 kV Transmission Line**  
 ■ MV-PN North Segment  
 Existing Great River Energy  
 — 69 kV Transmission Line

**Residence**  
 ● Within 150' (6)  
 ● Within 100' (6)  
 ● Within 75' (7)  
 ● Within 50' (6)

□ 300' route width

0 100 200 Feet

GIS Data sources include:  
 MNGEO, MNDNR, MNDOT,  
 and Great River Energy.  
 Aerial Imagery from ESRI web service

**Elko New Market and  
 Cleary Lake Areas Project  
 Appendix G  
 Prior Lake Junction to  
 Credit River Junction  
 Map Series 2 of 5**



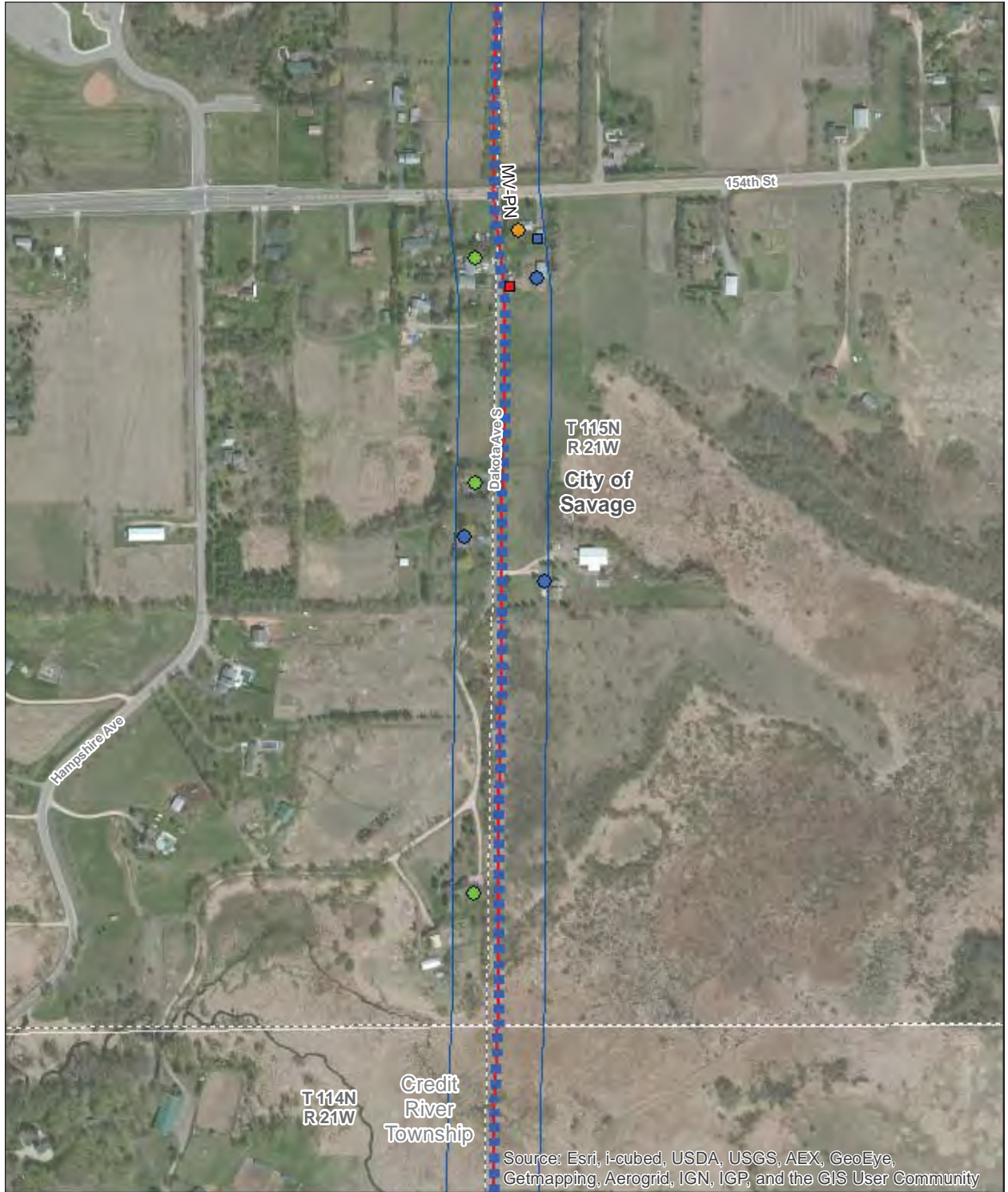

Source: Esri, i-cubed, USDA, USGS, AEX, GeoEye, Getmapping, Aerogrid, IGN, IGP, and the GIS User Community

**Proposed Great River Energy 115 kV Transmission Line**  
 ■ MV-PN North Segment  
 Existing Great River Energy  
 — 69 kV Transmission Line

- Residence
- Within 150' (3)
  - Within 100' (3)
  - Within 75' (1)
- Accessory
- Within 150' (1)
  - Within 50' (1)
- 300' route width

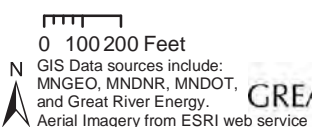

**Elko New Market and Cleary Lake Areas Project**  
**Appendix G**  
**Prior Lake Junction to Credit River Junction**  
**Map Series 3 of 5**







Source: Esri, i-cubed, USDA, USGS, AEX, GeoEye, Getmapping, Aerogrid, IGN, IGP, and the GIS User Community

<p><b>Proposed Great River Energy 115 kV Transmission Line</b></p> <ul style="list-style-type: none"> <li>■ MV-PN North Segment</li> <li>— Existing Great River Energy 69 kV Transmission Line</li> </ul>	<p><b>Residence</b></p> <ul style="list-style-type: none"> <li>● Within 75' (1)</li> </ul> <p><b>Accessory</b></p> <ul style="list-style-type: none"> <li>■ Within 150' (1)</li> <li>■ Within 100' (1)</li> <li>■ Within 75' (1)</li> </ul>	<p>□ 300' route width</p>	<p><b>Elko New Market and Cleary Lake Areas Project</b>  <b>Appendix G</b>  <b>Prior Lake Junction to Credit River Junction</b>  <b>Map Series 4 of 5</b></p>
---	---	---------------------------	---

0 100 200 Feet

GIS Data sources include:  
MNGEO, MNDNR, MNDOT,  
and Great River Energy.  
Aerial Imagery from ESRI web service





Source: Esri, i-cubed, USDA, USGS, AEX, GeoEye, Getmapping, Aerogrid, IGN, IGP, and the GIS User Community

**Proposed Great River Energy 115 kV Transmission Line**  
 ■ MV-PN North Segment  
 Existing Great River Energy  
 — 69 kV Transmission Line

**Residence**  
 ● Within 150' (1)  
 ● Within 100' (1)  
**Accessory**  
 ■ Within 150' (4)

□ 300' route width

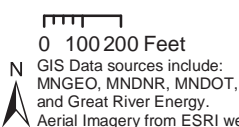

**Elko New Market and Cleary Lake Areas Project**  
**Appendix G**  
**Prior Lake Junction to Credit River Junction**  
**Map Series 5 of 5**



GIS Data sources include:  
 MNGEO, MNDNR, MNDOT,  
 and Great River Energy.  
 Aerial Imagery from ESRI web service



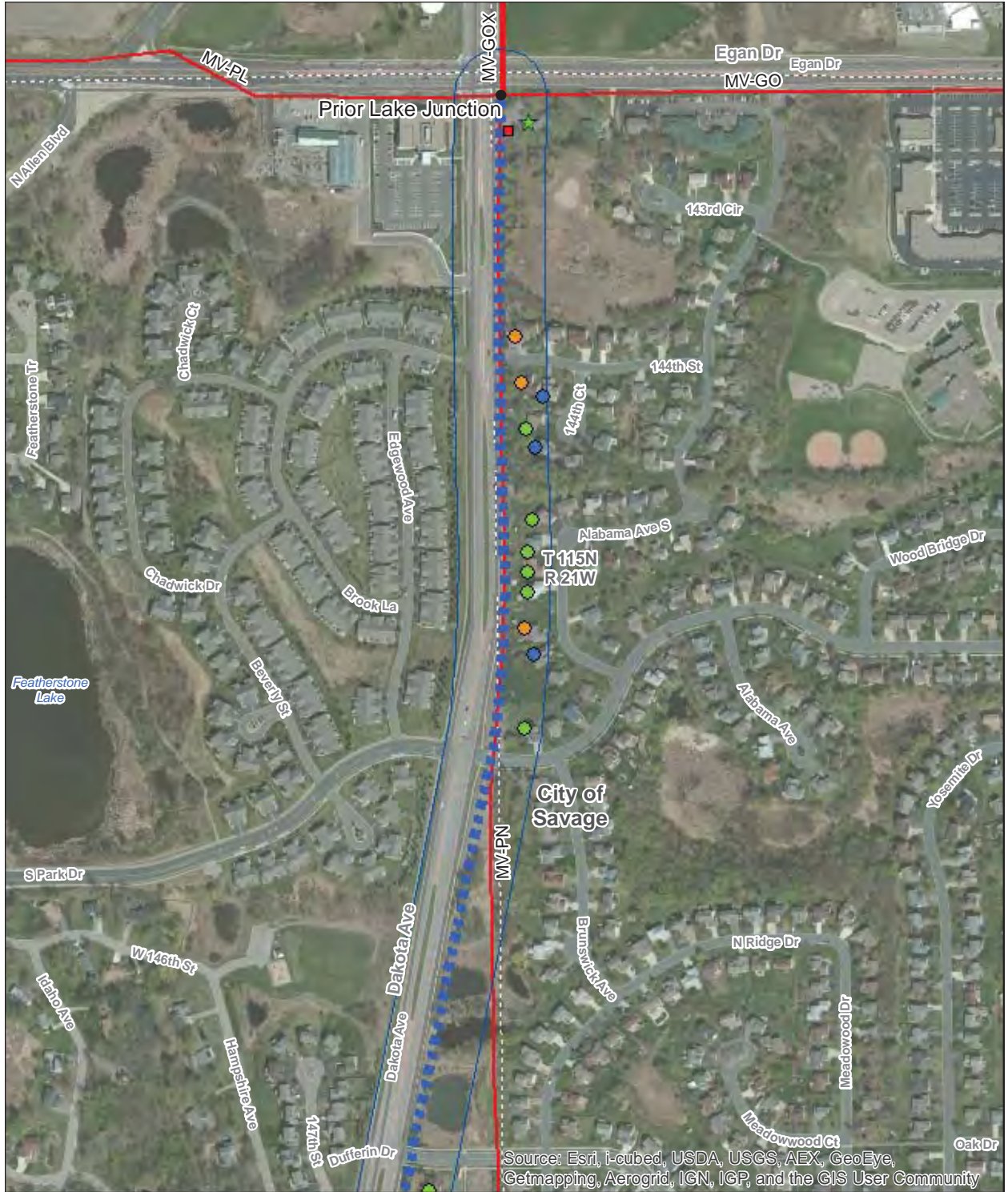

Source: Esri, i-cubed, USDA, USGS, AEX, GeoEye, Getmapping, Aerogrid, IGN, IGP, and the GIS User Community

**Proposed Great River Energy  
115 kV Transmission Line**  
 ■ MV-PN North Deviation Segment  
 Existing Great River Energy  
 — 69 kV Transmission Line

- Residence
  - Within 150' (3)
  - Within 100' (7)
  - Within 75' (3)
- Business
  - ★ Within 100' (1)
- Accessory
  - Within 50' (1)
- 300' route width

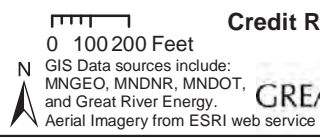

**Elko New Market and  
Cleary Lake Areas Project  
Appendix G  
Prior Lake Junction to  
Credit River Junction with Deviation  
Map Series 1 of 6**





Source: Esri, i-cubed, USDA, USGS, AEX, GeoEye, Getmapping, Aerogrid, IGN, IGP, and the GIS User Community

<p><b>Proposed Great River Energy 115 kV Transmission Line</b></p> <p>■ MV-PN North Deviation Segment</p> <p>Existing Great River Energy — 69 kV Transmission Line</p>	<p>Residence</p> <p>● Within 150' (6)</p> <p>● Within 100' (9)</p> <p>● Within 75' (1)</p>	<p>□ 300' route width</p>	<p><b>Elko New Market and Cleary Lake Areas Project Appendix G</b></p> <p><b>Prior Lake Junction to Credit River Junction with Deviation</b></p> <p><b>Map Series 2 of 6</b></p>
--	--	---------------------------	--

0 100 200 Feet

GIS Data sources include:  
MNGEO, MNDNR, MNDOT,  
and Great River Energy.

Aerial Imagery from ESRI web service

**GREAT RIVER ENERGY**

A Southern Energy Corporation

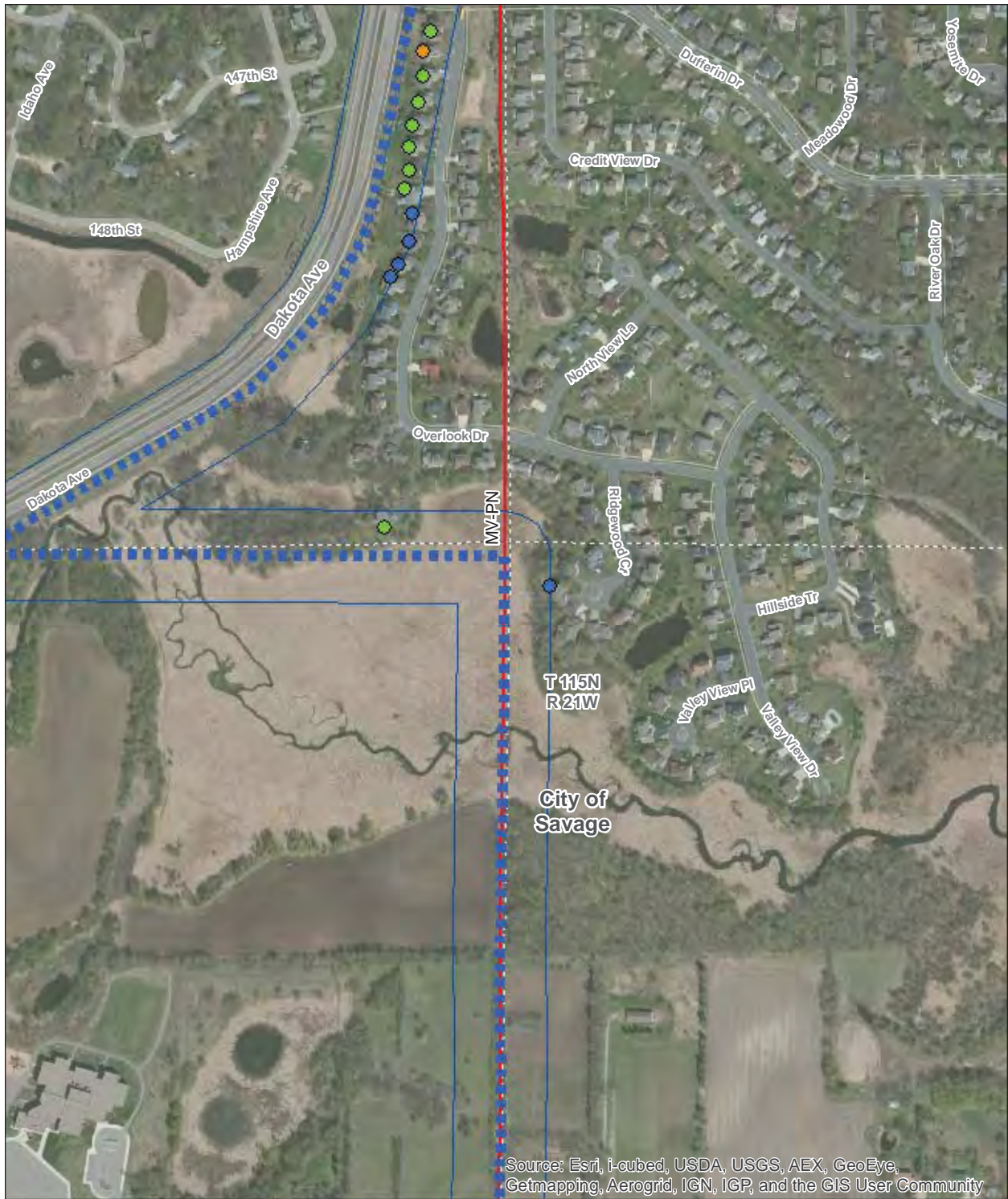

**Proposed Great River Energy**

- 115 kV Transmission Line**
- MV-PN North Deviation Segment
- Existing Great River Energy
- 69 kV Transmission Line

- Residence
- Within 150' (5)
  - Within 100' (8)
  - Within 75' (1)

□ 300' route width

0 100 200 Feet

GIS Data sources include:  
 MNGEO, MNDNR, MNDOT,  
 and Great River Energy.  
 Aerial Imagery from ESRI web service

**Elko New Market and  
 Cleary Lake Areas Project  
 Appendix G  
 Prior Lake Junction to  
 Credit River Junction with Deviation  
 Map Series 3 of 6**



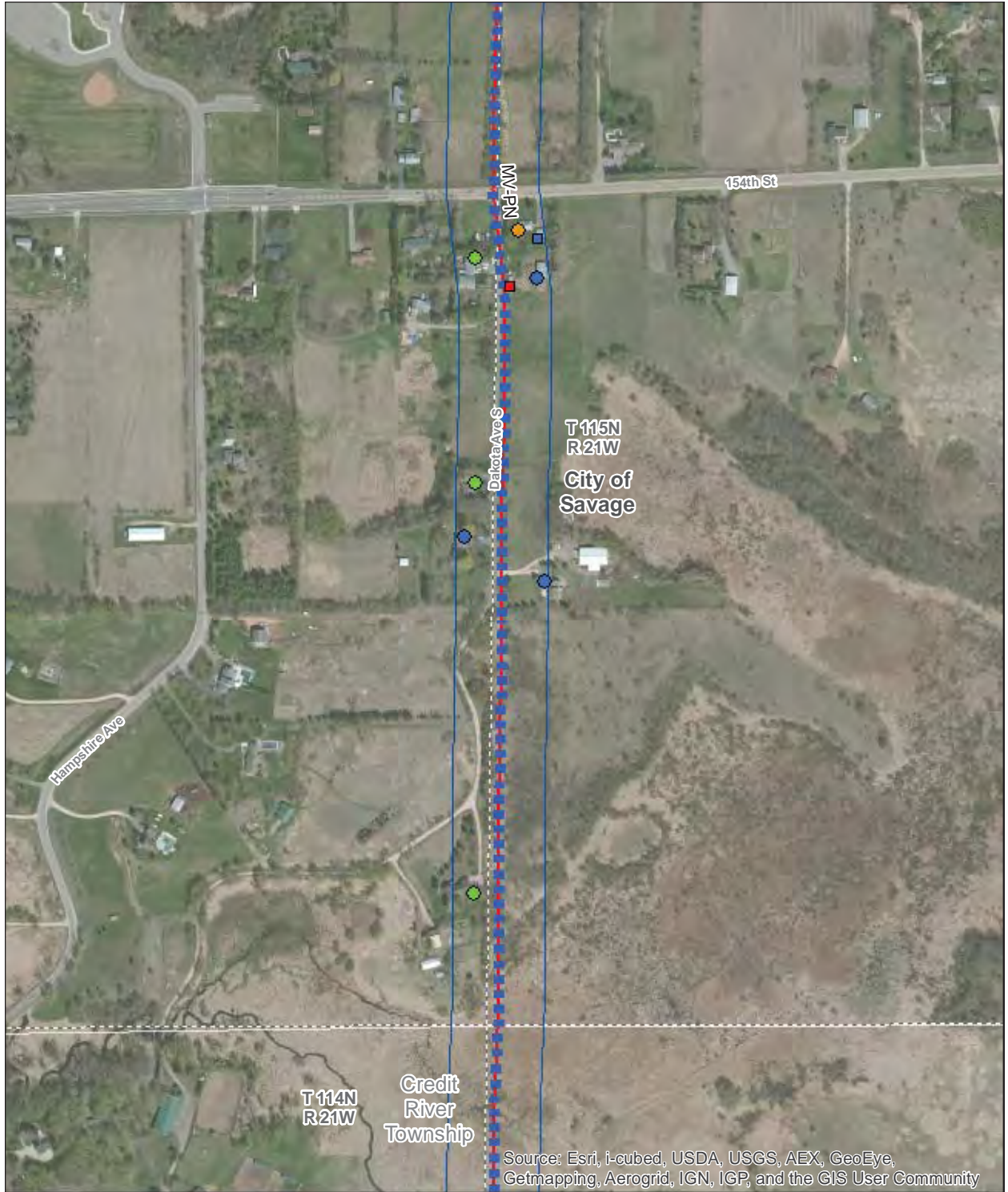

Source: Esri, i-cubed, USDA, USGS, AEX, GeoEye, Getmapping, Aerogrid, IGN, IGP, and the GIS User Community

**Proposed Great River Energy 115 kV Transmission Line**

- MV-PN North Deviation Segment
- Existing Great River Energy 69 kV Transmission Line

- Residence
- Within 150' (3)
  - Within 100' (3)
  - Within 75' (1)
- Accessory
- Within 150' (1)
  - Within 50' (1)

□ 300' route width



GIS Data sources include: MNGEO, MNDNR, MNDOT, and Great River Energy. Aerial Imagery from ESRI web service

**Elko New Market and Cleary Lake Areas Project Appendix G**  
**Prior Lake Junction to Credit River Junction with Deviation**  
**Map Series 4 of 6**





Source: Esri, i-cubed, USDA, USGS, AEX, GeoEye, Getmapping, Aerogrid, IGN, IGP, and the GIS User Community

**Proposed Great River Energy  
115 kV Transmission Line**

- MV-PN North Deviation Segment
- Existing Great River Energy  
— 69 kV Transmission Line

- Residence
- Within 75' (1)
- Accessory
- Within 150' (1)
  - Within 100' (1)
  - Within 75' (1)

□ 300' route width

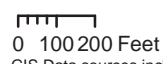

GIS Data sources include:  
MNGEO, MNDNR, MNDOT,  
and Great River Energy.  
Aerial Imagery from ESRI web service

**Elko New Market and  
Cleary Lake Areas Project  
Appendix G  
Prior Lake Junction to  
Credit River Junction with Deviation  
Map Series 5 of 6**





Source: Esri, i-cubed, USDA, USGS, AEX, GeoEye, Getmapping, Aerogrid, IGN, IGP, and the GIS User Community

<p><b>Proposed Great River Energy 115 kV Transmission Line</b></p>	<p>Residence  <span style="color: blue;">●</span> Within 150' (1)  <span style="color: green;">●</span> Within 100' (1)          Accessory  <span style="color: blue;">■</span> Within 150' (4)</p>	<p><span style="border: 1px solid blue; display: inline-block; width: 20px; height: 10px;"></span> 300' route width</p>	<p style="text-align: center;"><b>Elko New Market and Cleary Lake Areas Project Appendix G Prior Lake Junction to Credit River Junction with Deviation Map Series 6 of 6</b></p>
<p>Existing Great River Energy 69 kV Transmission Line</p>	<p>0 100 200 Feet</p>	<p>GIS Data sources include: MNGEO, MNDNR, MNDOT, and Great River Energy. Aerial Imagery from ESRI web service</p>	







Source: Esri, i-cubed, USDA, USGS, AEX, GeoEye, Getmapping, Aerogrid, IGN, IGP, and the GIS User Community

**Proposed Great River Energy 115 kV Transmission Line**  
 ■ ■ MV-CR Segment  
 Existing Great River Energy 69 kV Transmission Line

Accessory Within 150' (1)

300' route width

**Elko New Market and Cleary Lake Areas Project**  
**Appendix G**  
**Credit River Junction to Credit River Substation**  
**Map Series 1 of 4**

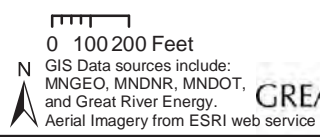

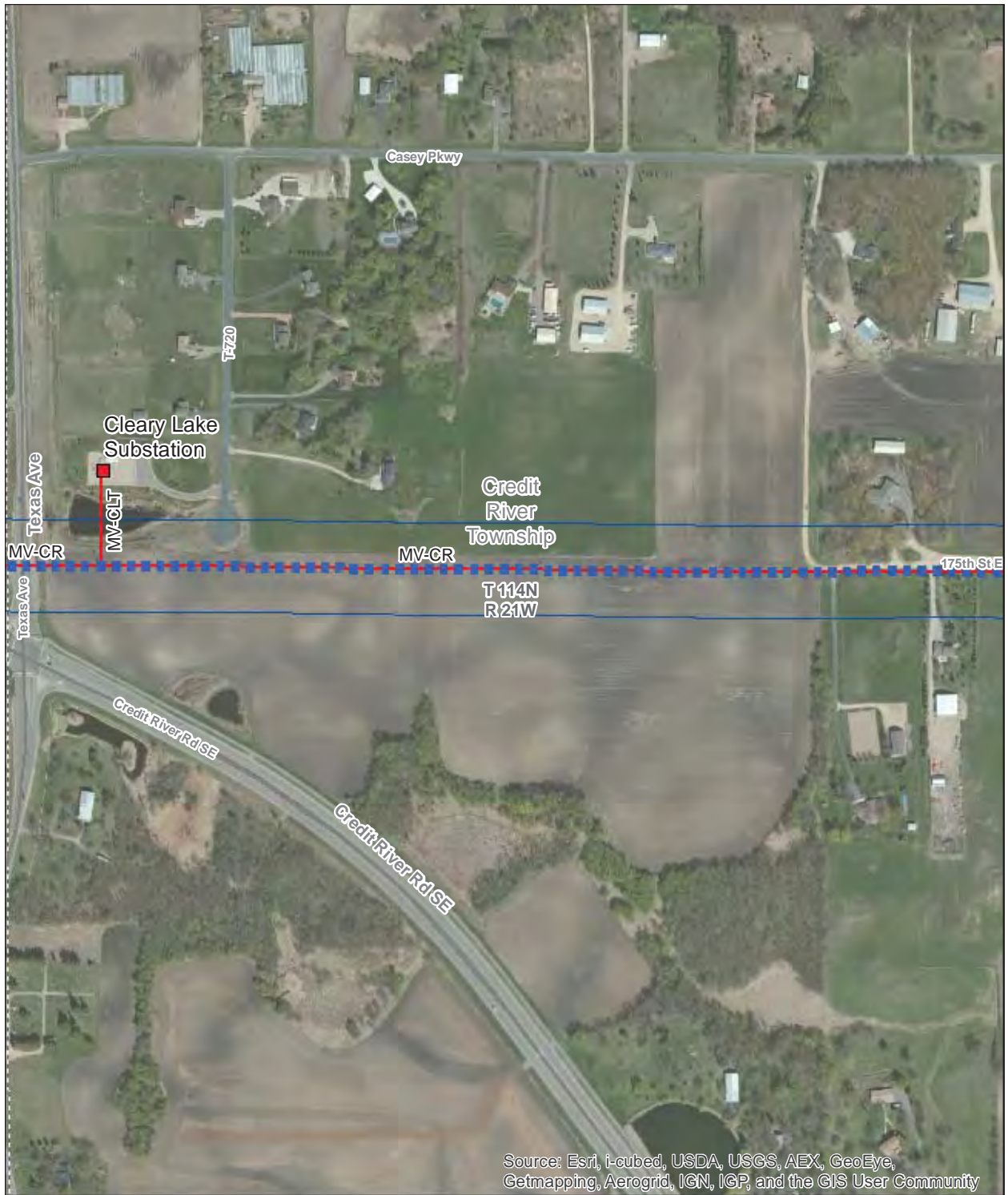

Source: Esri, i-cubed, USDA, USGS, AEX, GeoEye, Getmapping, Aerogrid, IGN, IGP, and the GIS User Community

- Proposed Great River Energy 115 kV Transmission Line
- 300' route width
- MV-CR Segment
- Existing Cooperative
- Distribution Substation
- Existing Great River Energy
- 69 kV Transmission Line

**Elko New Market and Cleary Lake Areas Project**  
**Appendix G**  
**Credit River Junction to Credit River Substation**  
**Map Series 2 of 4**

0 100 200 Feet

GIS Data sources include:  
 MNGEO, MNDNR, MNDOT,  
 and Great River Energy.

Aerial Imagery from ESRI web service

**GREAT RIVER ENERGY**

A Schriber Energy Corporation

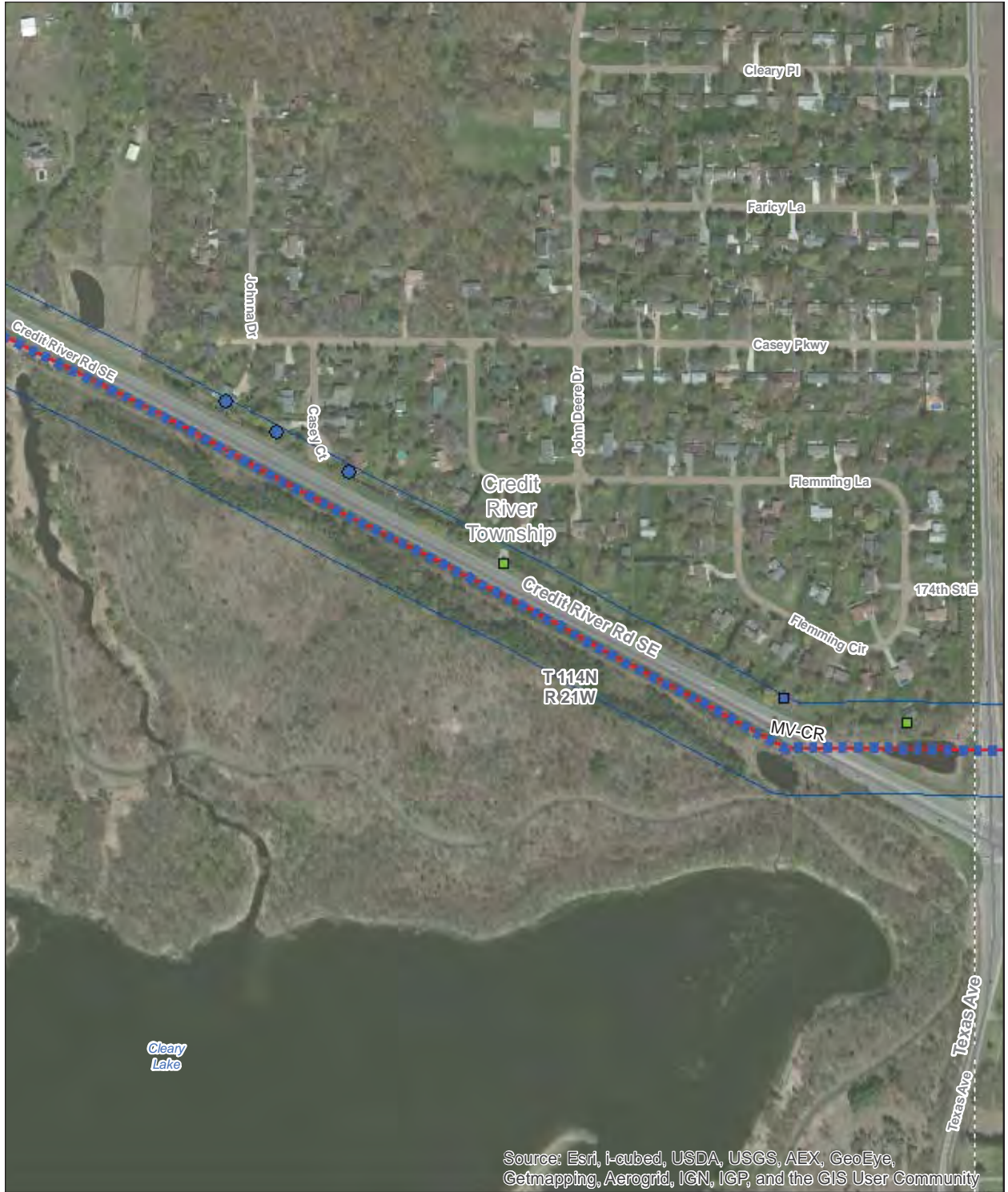

Source: Esri, i-cubed, USDA, USGS, AEX, GeoEye, Getmapping, Aerogrid, IGN, IGP, and the GIS User Community

**Proposed Great River Energy 115 kV Transmission Line**  
 ■ MV-CR Segment  
 Existing Great River Energy  
 — 69 kV Transmission Line

Residence  
 ● Within 150' (3)  
 Accessory  
 ■ Within 150' (1)  
 ■ Within 100' (2)

□ 300' route width

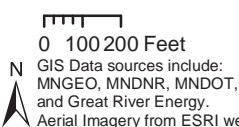

**Elko New Market and Cleary Lake Areas Project**  
**Appendix G**  
**Credit River Junction to Credit River Substation**  
**Map Series 3 of 4**





Source: Esri, i-cubed, USDA, USGS, AEX, GeoEye, Getmapping, Aerogrid, IGN, IGP, and the GIS User Community

- Proposed Great River Energy 115 kV Transmission Line**
- MV-CR Segment
- Existing Great River Energy 69 kV Transmission Line
- Existing Xcel Energy 69 kV Transmission Line
- Distribution Substation
- Business ★ Within 100' (1)
- 300' route width

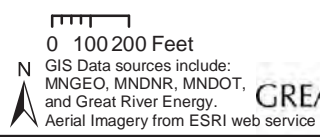

**Elko New Market and Cleary Lake Areas Project**  
**Appendix G**  
**Credit River Junction to Credit River Substation**  
**Map Series 4 of 4**





Source: Esri, i-cubed, USDA, USGS, AEX, GeoEye, Getmapping, Aerogrid, IGN, IGP, and the GIS User Community

- Proposed Great River Energy 115 kV Transmission Line**  300' route width
- MV-PN South Segment Existing Cooperative
- Distribution Substation
- Existing Great River Energy
- 69 kV Transmission Line

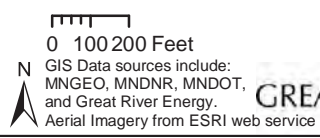

**Elko New Market and  
Cleary Lake Areas Project  
Appendix G  
245th Street to  
New Market Substation  
Map Series 1 of 9**





Source: Esri, i-cubed, USDA, USGS, AEX, GeoEye, Getmapping, Aerogrid, IGN, IGP, and the GIS User Community

**Proposed Great River Energy  
115 kV Transmission Line**  
 ■■ MV-PN South Segment  
 Existing Great River Energy  
 — 69 kV Transmission Line

- Residence
- Within 150' (2)
  - Within 50' (1)
- Accessory
- Within 150' (1)
  - Within 100' (1)

□ 300' route width

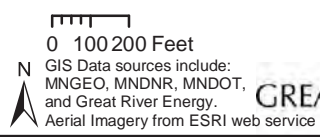

**Elko New Market and  
Cleary Lake Areas Project  
Appendix G  
245th Street to  
New Market Substation  
Map Series 2 of 9**





Source: Esri, i-cubed, USDA, USGS, AEX, GeoEye, Getmapping, Aerogrid, IGN, IGP, and the GIS User Community

**Proposed Great River Energy 115 kV Transmission Line**  
 ■ ■ MV-PN South Segment  
 Existing Great River Energy  
 — 69 kV Transmission Line

Residence  
 ● Within 150' (1)  
 Accessory  
 ■ Within 150' (3)

□ 300' route width

**Elko New Market and Cleary Lake Areas Project**  
**Appendix G**  
**245th Street to New Market Substation**  
**Map Series 3 of 9**

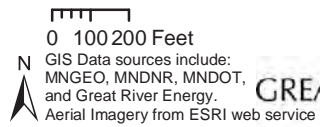



Source: Esri, i-cubed, USDA, USGS, AEX, GeoEye, Getmapping, Aerogrid, IGN, IGP, and the GIS User Community

**Proposed Great River Energy 115 kV Transmission Line**  300' route width  
 ■ ■ MV-PN South Segment  
 Existing Great River Energy  
 — 69 kV Transmission Line

**Elko New Market and  
 Cleary Lake Areas Project  
 Appendix G  
 245th Street to  
 New Market Substation  
 Map Series 4 of 9**

0 100 200 Feet  
 GIS Data sources include:  
 MNGEO, MNDNR, MNDOT,  
 and Great River Energy.  
 Aerial Imagery from ESRI web service







Source: Esri, i-cubed, USDA, USGS, AEX, GeoEye, Getmapping, Aerogrid, IGN, IGP, and the GIS User Community

- Proposed Great River Energy 115 kV Transmission Line  300' route width
- ■ MV-PN South Segment
- Existing Great River Energy
- 69 kV Transmission Line

**Elko New Market and  
 Cleary Lake Areas Project  
 Appendix G  
 245th Street to  
 New Market Substation  
 Map Series 5 of 9**

0 100 200 Feet  
 GIS Data sources include:  
 MNGEO, MNDNR, MNDOT,  
 and Great River Energy.  
 Aerial Imagery from ESRI web service





Source: Esri, i-cubed, USDA, USGS, AEX, GeoEye, Getmapping, Aerogrid, IGN, IGP, and the GIS User Community

- Proposed Great River Energy 115 kV Transmission Line  300' route width
- ■ MV-PN South Segment
- Existing Great River Energy
- 69 kV Transmission Line

**Elko New Market and  
Cleary Lake Areas Project  
Appendix G  
245th Street to  
New Market Substation  
Map Series 6 of 9**

0 100 200 Feet  
 GIS Data sources include:  
 MNGEO, MNDNR, MNDOT,  
 and Great River Energy.  
 Aerial Imagery from ESRI web service



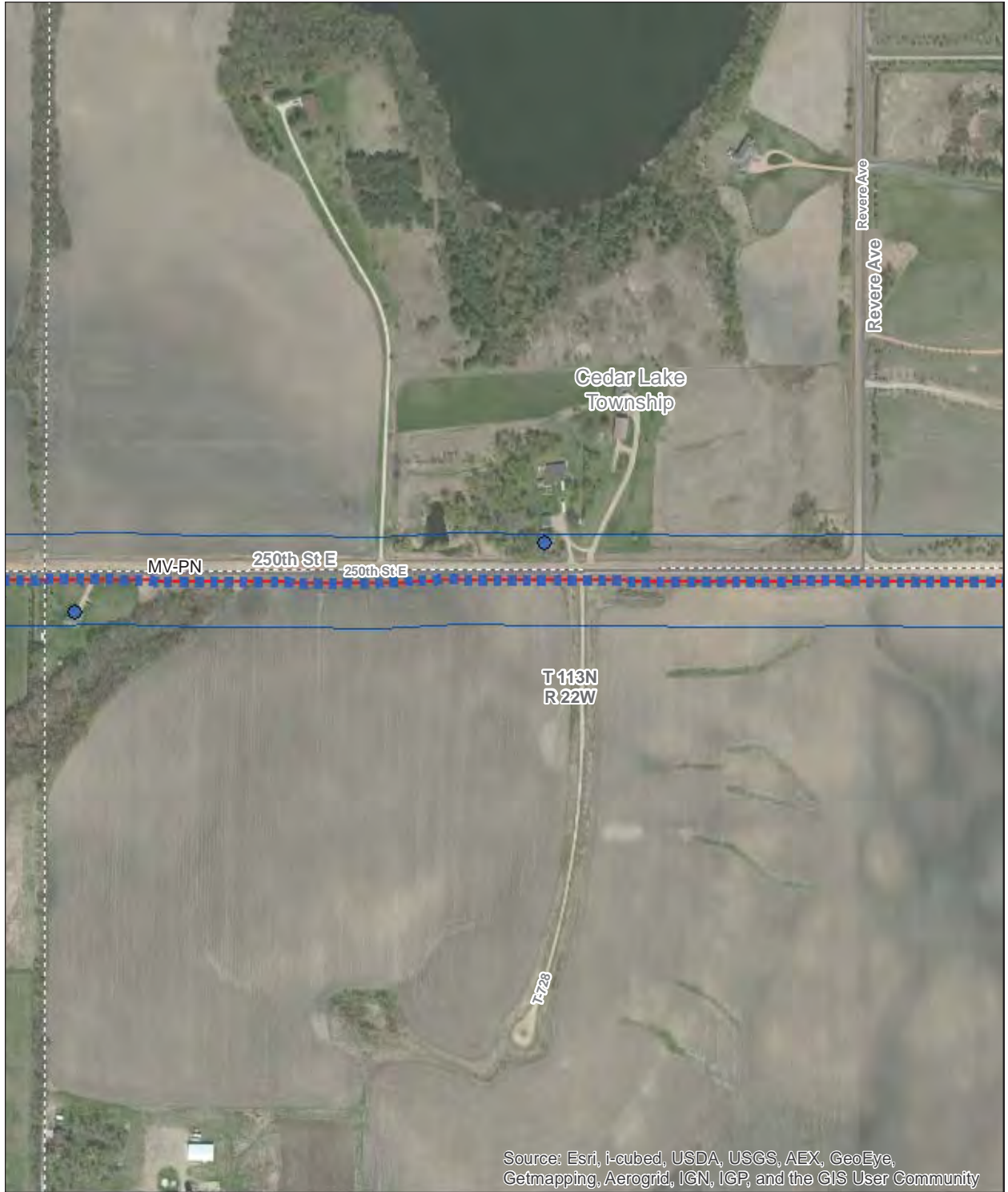

Source: Esri, i-cubed, USDA, USGS, AEX, GeoEye, Getmapping, Aerogrid, IGN, IGP, and the GIS User Community

**Proposed Great River Energy  
115 kV Transmission Line**  
 ■ ■ MV-PN South Segment  
 Existing Great River Energy  
 — 69 kV Transmission Line

Residence  
 ● Within 150' (2)    □ 300' route width

**Elko New Market and  
Cleary Lake Areas Project  
Appendix G  
245th Street to  
New Market Substation  
Map Series 7 of 9**

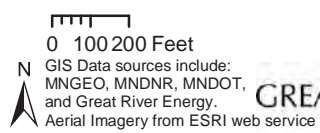



Source: Esri, i-cubed, USDA, USGS, AEX, GeoEye, Getmapping, Aerogrid, IGN, IGP, and the GIS User Community

**Proposed Great River Energy 115 kV Transmission Line**  300' route width  
**MV-PN South Segment**   
**Existing Great River Energy 69 kV Transmission Line**

**Elko New Market and Cleary Lake Areas Project**  
**Appendix G**  
**245th Street to New Market Substation**  
**Map Series 8 of 9**



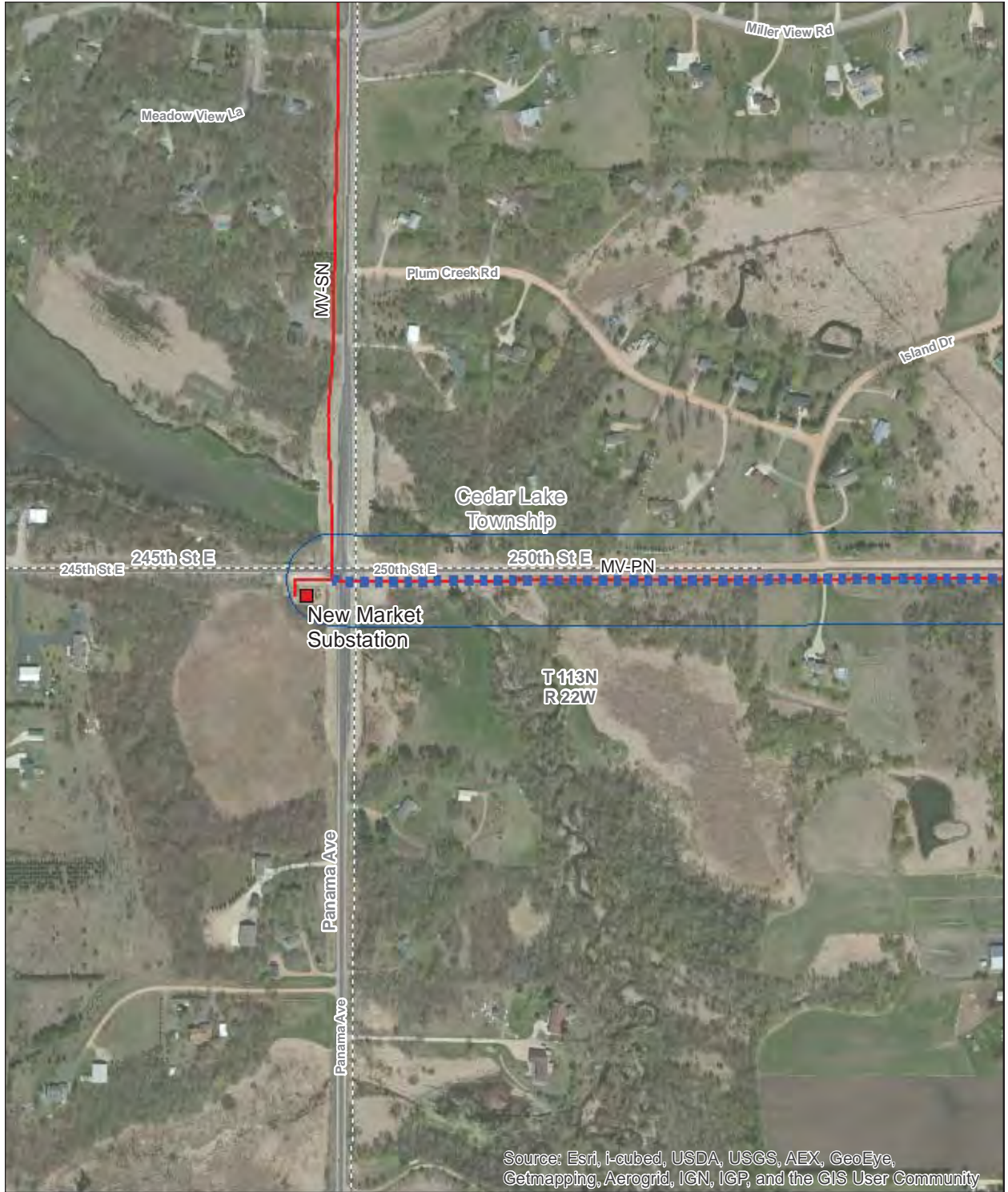

Source: Esri, i-cubed, USDA, USGS, AEX, GeoEye, Getmapping, Aerogrid, IGN, IGP, and the GIS User Community

- Proposed Great River Energy 115 kV Transmission Line**  300' route width
- MV-PN South Segment Existing Cooperative
- Distribution Substation Existing Great River Energy
- 69 kV Transmission Line

**Elko New Market and  
Cleary Lake Areas Project  
Appendix G  
245th Street to  
New Market Substation  
Map Series 9 of 9**

0 100 200 Feet  
 GIS Data sources include:  
 MNGEO, MNDNR, MNDOT,  
 and Great River Energy.  
 Aerial Imagery from ESRI web service







Source: Esri, i-cubed, USDA, USGS, AEX, GeoEye, Getmapping, Aerogrid, IGN, IGP, and the GIS User Community

**Proposed Great River Energy 115 kV Transmission Line**  
 ■ East Segment  
 Existing Great River Energy 69 kV Transmission Line

**Accessory**  
 ■ Within 150' (1)  
 ■ Within 100' (1)  
 ■ Within 50' (2)

□ 300' route width



GIS Data sources include: MNGEO, MNDNR, MNDOT, and Great River Energy. Aerial Imagery from ESRI web service

**Elko New Market and Cleary Lake Areas Project**  
**Appendix G**  
**250th Street to Veseli Breaker Station (East Option)**  
**Map Series 1 of 11**





Source: Esri, i-cubed, USDA, USGS, AEX, GeoEye, Getmapping, Aerogrid, IGN, IGP, and the GIS User Community

**Proposed Great River Energy 115 kV Transmission Line**  
 ■ ■ East Segment

□ 300' route width

**Elko New Market and Cleary Lake Areas Project**  
**Appendix G**  
**250th Street to Veseli Breaker Station (East Option)**  
**Map Series 2 of 11**

0 100 200 Feet  
 GIS Data sources include:  
 MNGEO, MNDNR, MNDOT,  
 and Great River Energy.  
 Aerial Imagery from ESRI web service







Source: Esri, i-cubed, USDA, USGS, AEX, GeoEye, Getmapping, Aerogrid, IGN, IGP, and the GIS User Community

Proposed Great River Energy 115 kV Transmission Line  
 ■ ■ East Segment

300' route width

**Elko New Market and Cleary Lake Areas Project**  
**Appendix G**  
**250th Street to Veseli Breaker Station (East Option)**  
**Map Series 3 of 11**

0 100 200 Feet  
 GIS Data sources include:  
 MNGEO, MNDNR, MNDOT,  
 and Great River Energy.  
 Aerial Imagery from ESRI web service





Source: Esri, i-cubed, USDA, USGS, AEX, GeoEye, Getmapping, Aerogrid, IGN, IGP, and the GIS User Community

**Proposed Great River Energy  
115 kV Transmission Line**  
■ East Segment

- Residence**
- Within 150' (2)
  - Within 100' (1)
  - Within 75' (2)
- Accessory**
- Within 150' (1)

□ 300' route width

**Elko New Market and  
Cleary Lake Areas Project  
Appendix G  
250th Street to  
Veseli Breaker Station (East Option)  
Map Series 4 of 11**

0 100 200 Feet

GIS Data sources include:  
MNGEO, MNDNR, MNDOT,  
and Great River Energy.  
Aerial Imagery from ESRI web service

**GREAT RIVER ENERGY**

A Schriber Energy Corporation



Source: Esri, i-cubed, USDA, USGS, AEX, GeoEye, Getmapping, Aerogrid, IGN, IGP, and the GIS User Community

**Proposed Great River Energy  
115 kV Transmission Line**  
■ ■ East Segment

Residence  
● Within 150' (1)  
Accessory  
■ Within 100' (1)

□ 300' route width

**Elko New Market and  
Cleary Lake Areas Project  
Appendix G  
250th Street to  
Veseli Breaker Station (East Option)  
Map Series 5 of 11**

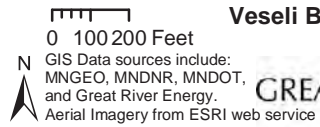



Source: Esri, i-cubed, USDA, USGS, AEX, GeoEye, Getmapping, Aerogrid, IGN, IGP, and the GIS User Community

**Proposed Great River Energy  
115 kV Transmission Line**  
 ■ ■ East Segment

Residence  
 ● Within 150' (1)  
 Accessory  
 ■ Within 150' (2)

□ 300' route width

**Elko New Market and  
Cleary Lake Areas Project  
Appendix G  
250th Street to  
Veseli Breaker Station (East Option)  
Map Series 6 of 11**

0 100 200 Feet  
 GIS Data sources include:  
 MNGEO, MNDNR, MNDOT,  
 and Great River Energy.  
 Aerial Imagery from ESRI web service





Source: Esri, i-cubed, USDA, USGS, AEX, GeoEye, Getmapping, Aerogrid, IGN, IGP, and the GIS User Community

**Proposed Great River Energy 115 kV Transmission Line**  
 ■ ■ East Segment

□ 300' route width

**Elko New Market and Cleary Lake Areas Project**  
**Appendix G**  
**250th Street to Veseli Breaker Station (East Option)**  
**Map Series 7 of 11**

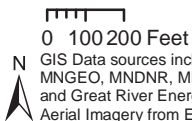

GIS Data sources include:  
 MNGEO, MNDNR, MNDOT,  
 and Great River Energy.



A Schwaninger Corporation



Source: Esri, i-cubed, USDA, USGS, AEX, GeoEye, Getmapping, Aerogrid, IGN, IGP, and the GIS User Community

**Proposed Great River Energy 115 kV Transmission Line**  
 ■ ■ East Segment  
 Accessory  
 ■ Within 150' (3)  
 □ 300' route width

**Elko New Market and Cleary Lake Areas Project**  
**Appendix G**  
**250th Street to Veseli Breaker Station (East Option)**  
**Map Series 8 of 11**

0 100 200 Feet  
 GIS Data sources include:  
 MNGEO, MNDNR, MNDOT,  
 and Great River Energy.  
 Aerial Imagery from ESRI web service





Source: Esri, i-cubed, USDA, USGS, AEX, GeoEye, Getmapping, Aerogrid, IGN, IGP, and the GIS User Community

**Proposed Great River Energy 115 kV Transmission Line**  
 ■ ■ East Segment  
 Accessory  
 ■ Within 150' (3)  
 □ 300' route width

**Elko New Market and Cleary Lake Areas Project**  
**Appendix G**  
**250th Street to Veseli Breaker Station (East Option)**  
**Map Series 9 of 11**

0 100 200 Feet  
 GIS Data sources include:  
 MNGEO, MNDNR, MNDOT,  
 and Great River Energy.  
 Aerial Imagery from ESRI web service





Source: Esri, i-cubed, USDA, USGS, AEX, GeoEye, Getmapping, Aerogrid, IGN, IGP, and the GIS User Community

**Proposed Great River Energy  
115 kV Transmission Line**  
■ ■ East Segment

- Residence  
 ● Within 150' (1)  
 ● Within 75' (1)  
 Accessory  
 ■ Within 150' (2)

□ 300' route width

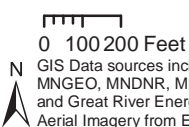

GIS Data sources include:  
 MNGEO, MNDNR, MNDOT,  
 and Great River Energy.  
 Aerial Imagery from ESRI web service

**Elko New Market and  
 Cleary Lake Areas Project  
 Appendix G  
 250th Street to  
 Veseli Breaker Station (East Option)  
 Map Series 10 of 11**







Source: Esri, i-cubed, USDA, USGS, AEX, GeoEye, Getmapping, Aerogrid, IGN, IGP, and the GIS User Community

<p><b>Proposed Great River Energy 115 kV Transmission Line</b></p> <p>■ East Segment</p> <p>Existing Great River Energy 69 kV Transmission Line</p> <p>Proposed Xcel Energy 69 kV Breaker Station</p> <p>Existing Xcel Energy 69 kV Transmission Line</p>	<p>Accessory</p> <p>■ Within 150' (1)</p>	<p>□ 300' route width</p>	<p>0 100 200 Feet</p> <p>GIS Data sources include: MNGEO, MNDNR, MNDOT, and Great River Energy.</p> <p>Aerial Imagery from ESRI web service</p>	<p><b>Elko New Market and Cleary Lake Areas Project</b></p> <p><b>Appendix G</b></p> <p><b>250th Street to Veseli Breaker Station (East Option)</b></p> <p><b>Map Series 11 of 11</b></p> <p><b>GREAT RIVER ENERGY</b></p> <p>A Schwan-Elbert Corporation</p>
---	---	---------------------------	---	---





Source: Esri, i-cubed, USDA, USGS, AEX, GeoEye, Getmapping, Aerogrid, IGN, IGP, and the GIS User Community

**Proposed Great River Energy 115 kV Transmission Line**  
 ■ West Segment  
 Existing Cooperative  
 ■ Distribution Substation  
 Existing Great River Energy  
 — 69 kV Transmission Line

Residence  
 ● Within 150' (1)  
 ● Within 100' (1)

□ 300' route width

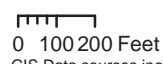

GIS Data sources include:  
 MNGEO, MNDNR, MNDOT,  
 and Great River Energy.  
 Aerial Imagery from ESRI web service

**Elko New Market and Cleary Lake Areas Project**  
**Appendix G**  
**New Market Substation to Veseli Breaker Station (West Option)**  
**Map Series 1 of 9**





Source: Esri, i-cubed, USDA, USGS, AEX, GeoEye, Getmapping, Aerogrid, IGN, IGP, and the GIS User Community

**Proposed Great River Energy 115 kV Transmission Line**  
 ■ ■ West Segment  
 Residence ● Within 150' (1)  
 □ 300' route width

**Elko New Market and Cleary Lake Areas Project Appendix G**  
**New Market Substation to Veseli Breaker Station (West Option)**  
 Map Series 2 of 9

0 100 200 Feet  
 GIS Data sources include: MNGEO, MNDNR, MNDOT, and Great River Energy.  
 Aerial Imagery from ESRI web service



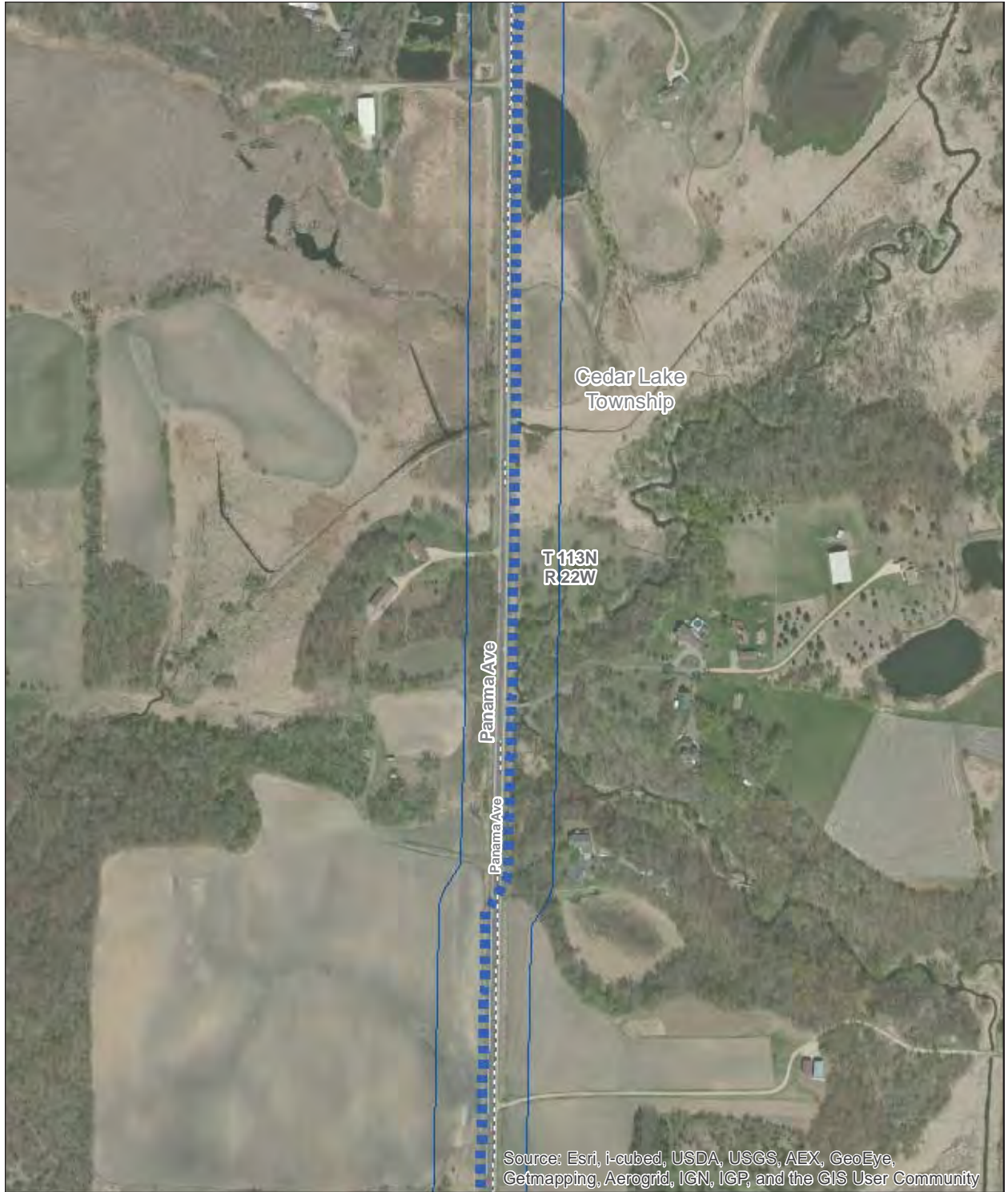

Source: Esri, i-cubed, USDA, USGS, AEX, GeoEye, Getmapping, Aerogrid, IGN, IGP, and the GIS User Community

**Proposed Great River Energy 115 kV Transmission Line**  300' route width  
 West Segment

**Elko New Market and Cleary Lake Areas Project**  
**Appendix G**  
**New Market Substation to Veseli Breaker Station (West Option)**  
**Map Series 3 of 9**

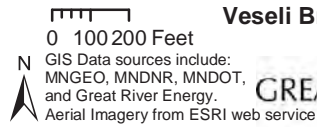



Source: Esri, i-cubed, USDA, USGS, AEX, GeoEye, Getmapping, Aerogrid, IGN, IGP, and the GIS User Community

**Proposed Great River Energy 115 kV Transmission Line**  300' route width  
 West Segment

**Elko New Market and Cleary Lake Areas Project**  
**Appendix G**  
**New Market Substation to Veseli Breaker Station (West Option)**  
**Map Series 4 of 9**

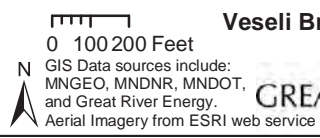



Source: Esri, i-cubed, USDA, USGS, AEX, GeoEye, Getmapping, Aerogrid, IGN, IGP, and the GIS User Community

**Proposed Great River Energy 115 kV Transmission Line**  
 ■ ■ West Segment

300' route width

**Elko New Market and Cleary Lake Areas Project**  
**Appendix G**  
**New Market Substation to Veseli Breaker Station (West Option)**  
**Map Series 5 of 9**

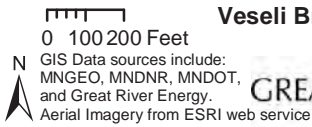



Proposed Great River Energy 115 kV Transmission Line  300' route width  
 West Segment

**Elko New Market and  
 Cleary Lake Areas Project  
 Appendix G  
 New Market Substation to  
 Veseli Breaker Station (West Option)  
 Map Series 6 of 9**

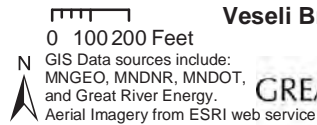





Source: Esri, i-cubed, USDA, USGS, AEX, GeoEye, Getmapping, Aerogrid, IGN, IGP, and the GIS User Community

Proposed Great River Energy 115 kV Transmission Line  
 ■ ■ West Segment

300' route width

**Elko New Market and Cleary Lake Areas Project**  
**Appendix G**  
**New Market Substation to Veseli Breaker Station (West Option)**  
**Map Series 7 of 9**

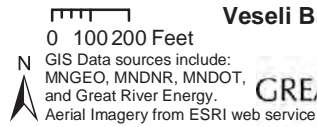



Source: Esri, i-cubed, USDA, USGS, AEX, GeoEye, Getmapping, Aerogrid, IGN, IGP, and the GIS User Community

**Proposed Great River Energy  
115 kV Transmission Line**  
 ■ ■ West Segment

- Residence  
 ● Within 150' (1)  
 ● Within 75' (1)  
 Accessory  
 ■ Within 150' (2)

□ 300' route width

**Elko New Market and  
Cleary Lake Areas Project  
Appendix G  
New Market Substation to  
Veseli Breaker Station (West Option)  
Map Series 8 of 9**

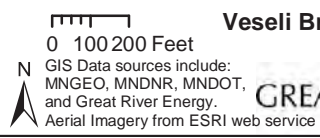



Source: Esri, i-cubed, USDA, USGS, AEX, GeoEye, Getmapping, Aerogrid, IGN, IGP, and the GIS User Community

<b>Proposed Great River Energy 115 kV Transmission Line</b>	Accessory	300' route width	<p><b>Elko New Market and Cleary Lake Areas Project</b>  <b>Appendix G</b>  <b>New Market Substation to Veseli Breaker Station (West Option)</b>  <b>Map Series 9 of 9</b></p>
■ West Segment	■ Within 150' (1)		
Existing Great River Energy 69 kV Transmission Line			<p>0 100 200 Feet</p> <p>GIS Data sources include:  MNGEO, MNDNR, MNDOT,  and Great River Energy.</p> <p><b>GREAT RIVER ENERGY</b>  <small>A Schwan-Elmop Corporation</small></p> 
Proposed Xcel Energy 69 kV Breaker Station			
Existing Xcel Energy 69 kV Transmission Line			

N



Aerial Imagery from ESRI web service

**THIS PAGE INTENTIONALLY BLANK**

# **APPENDIX H**

## **New Prague Area Load Serving Study**

**THIS PAGE INTENTIONALLY BLANK**

---

# **New Prague Area Load Serving Study**

---

Great River Energy, Xcel Energy, ITCM and SMMPA.

March 5, 2013

Prepared By:  
Yewulsew Atnafu- Great River Energy  
Harliv Singh - Xcel Energy

## Contents

1. Introduction .....	1
2. Background .....	3
3. Models and Study Assumptions.....	4
4. Analysis.....	9
4.1 Existing System Condition (2012).....	9
4.2 Future System Conditions (2016).....	17
5. Mitigation Plans .....	24
5.1 Using Sheas Lake as a Source: .....	26
5.1.1 Option 1(a)-Build a new 69 kV line from Sheas Lake to New Prague .....	26
5.1.2 Option 1(b) - Build a new 69 kV line from Sheas Lake to New Prague and 115 kV line between Scott County and Sheas Lake.....	27
5.2 Using Lake Marion/Chub Lake as a Source: .....	28
5.2.1 Option 2(a)-Build a new 115 kV line from Lake Marion to Veseli Substation .....	29
5.2.2 Option 2(b)-Rebuild existing 69 kV line from Lake Marion Substation to New Market and build a new double circuit line between New Market and Veseli. ....	33
6. ACCC/Contingency Analysis Results: .....	40
6.1 Load Serving Performance of Option 2(a) .....	40
6.1.1 Incremental Load Analysis.....	40
6.2 Load Serving Performance of Option 2(b) .....	41
6.2.1 Incremental Load Analysis.....	41
7. Economic Analysis.....	42
8. Present Worth Analysis.....	46
9. Conclusion .....	47
<i>Appendix A: System Historical Load.....</i>	<i>49</i>
<i>Appendix B: System Base Load for Incremental Load.....</i>	<i>51</i>
<i>Appendix C: Contingency analysis results of existing system.....</i>	<i>52</i>
<i>Appendix D: Contingency Analysis results of Future System .....</i>	<i>55</i>
<i>Appendix E: P-V Curves with Option 2(a).....</i>	<i>60</i>
<i>Appendix F: P-V Curves with Option 2(b).....</i>	<i>62</i>
<i>Appendix G: Present Worth Table .....</i>	<i>66</i>
<i>Appendix H: System One-line Diagrams.....</i>	<i>68</i>



# 1. Introduction

This study was performed to address the thermal and voltage violations and the long term needs of the transmission system that serves areas southwest of the Twin Cities metro area. The “study area” is defined to consist all areas that are served from GRE Member Cooperative-owned and Non-GRE Member Cooperative-owned distribution substations in the shaded area shown in the map below. The transmission system serving the study area consists of extensive 69 kV transmission networks, which are mostly constructed in the 1960s and 1970s. The majority of the transmission system consists of 4/0A or smaller size conductors which present low capacity and high impedance characteristics in the transmission system. The low capacity conductors are sources for line overload concerns and the high impedance characteristic results higher power loss and voltage drop across the transmission system.

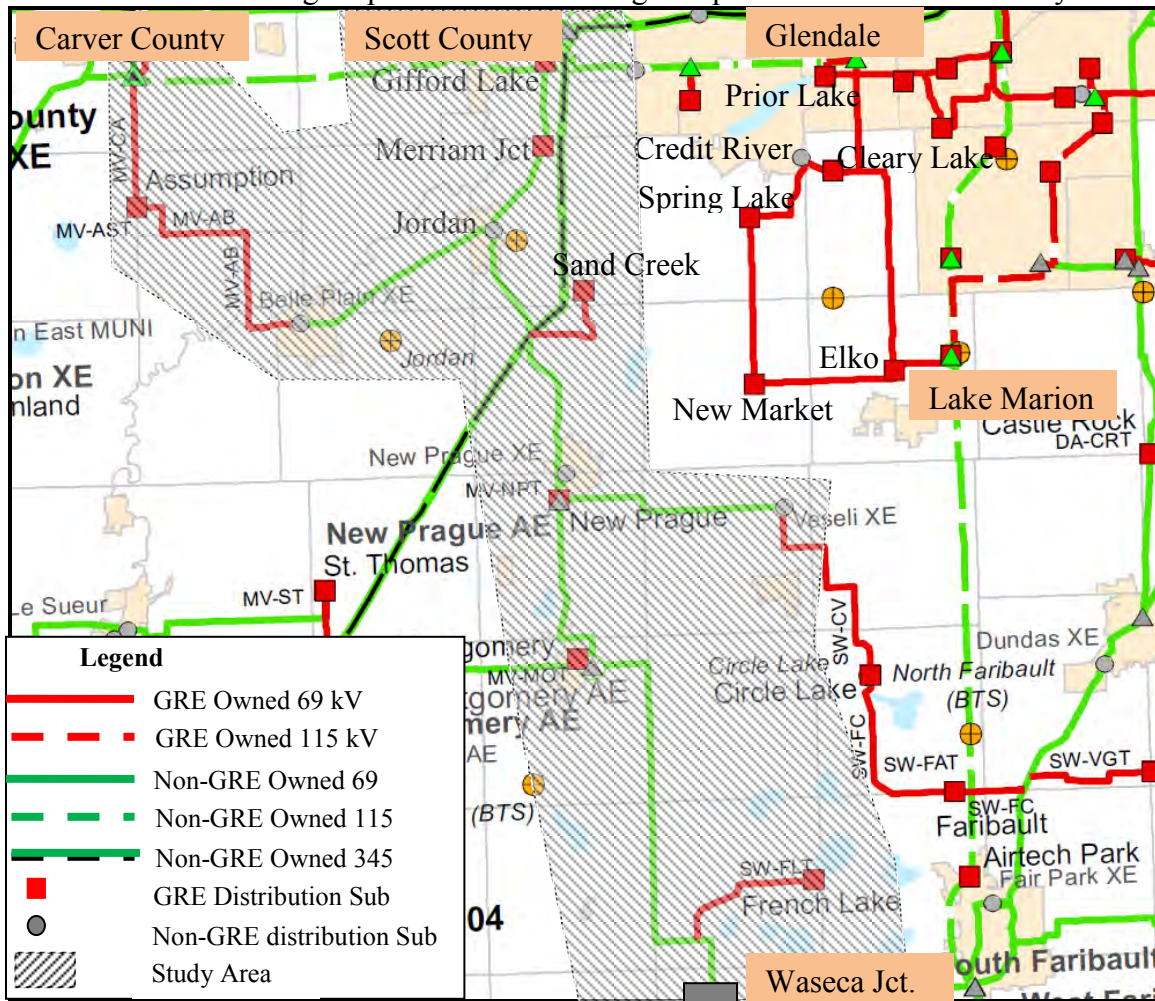

**Figure 1.1: Geographical map of the study area**

The major sources to this transmission system, such as Carver County, Scott County, Owatonna and Loon Lake are significantly far apart, thereby the loss of one of the sources to the study area present an overload or voltage concerns. The affected load areas include the areas served from the Gifford Lake, Merriam Junction, Jordan, Assumption, Belle Plaine, Sand Creek, New Prague, Veseli, and French Lake substations. Loads served from these substations are referred to as the “New Prague Area Loads” throughout this study.

The following assumptions were taken into consideration as alternative solutions were devised in the study:

1. Any operating procedures such as use of line switching as a solution during an outage were identified to be short-term and localized.
2. Local generation may be used to provide short-term voltage support during a transmission outage, but it was not studied as a long-term solution for study area.
3. All the existing capacitor banks in the study area were assumed to be turned on at all times during an outage.

To address the low voltage and overload concerns in the study area, this study report proposes a preferred solution which includes a rebuild of existing transmission lines and construction of a new double circuit 69 kV line from the New Market area to NSP's Veseli distribution substation. This line splits the New Market to Elko 69 kV line and introduces the Glendale and Lake Marion 115/69 kV sources to the study area to assist existing sources serving the New Prague Area Loads. This solution makes the overall transmission system redundant. One of the two circuits links the Glendale 115/69 kV source to the New Prague area via the 69 kV lines that connect Spring Lake, New Market and Veseli substations. This circuit is proposed to be built using a 795 ACSS/ACSR conductor and will be constructed to 115 kV standards for future 115 kV operation. The other circuit will also be built using 795 ACSS/ACSR conductor and will tie the Lake Marion 115/69 kV source to the New Prague Area loads via the 69 kV lines connecting the Lake Marion, Elko and Veseli substations. This line will be constructed to 115 kV standards for future 115 kV operation.

This report also discusses three other transmission alternatives that were also analyzed as potential solutions to the needs of the transmission system in the study area. The first alternative includes construction of a new 115 kV line from Lake Marion to Veseli and establishing a new 115/69 kV substation at Veseli. This alternative, however, was not found to be the best value plan when compared to the preferred option. Two additional alternatives were also studied and include use of the Sheas Lake substation as a source to the study area. However, building a new line from the Sheas Lake substation does not fully address the transmission issues in the New Prague area as the area would inherit potential problems due to the Mankato Energy Center special protection scheme which can lead to the unavailability of the 345 kV support during contingencies. Also during a 345 kV line outage, through flow on 69 kV lines emanating from Wilmarth during a 345 kV line outage will also cause thermal loading concerns on the 69 kV system in the new Prague Area as well as on the 69 kV system between Sheas Lake and Wilmarth.

The study participants include Great River Energy, Xcel Energy (NSP), Southern Minnesota Municipal Power Agency and ITC Midwest (ITCM).

## 2. Background

The New Prague area load is located southwest of the Twin Cities Metro area. At present, the study area load is primarily supported by Scott County and Carver County sources in the north. The Scott County source is the stronger source by virtue of newly rebuilt high capacity and low resistance lines, which are connected to the substation. The load area is also weakly supported by other distant sources such as the West Owatonna and Loon Lake substations located southeast and southwest of the study area, respectively.

The 69 kV transmission lines from Scott County and Carver County form a nexus at the Jordan substation, and a long 69 kV transmission line from Jordan south in the study area links the West Owatonna and Loon Lake sources. The transmission system in the study area includes 795 ACSR, 336 ACSR, and 4/0A, or smaller size, conductors. The vast majority of the transmission system consists of 4/0A or smaller size conductors. These conductors experience overload concerns due their current carrying capability.

As past studies including, Great River Energy's Annual System Assessment showed, multiple contingencies in the transmission system in the study area cause criteria violations, in particular low voltage and overload problems. Of these contingencies the loss of Scott County to Gifford Lake 69 kV line causes severe low voltages and thermal loading concerns in the study area. Similarly, the loss of Jordan to Sand Creek 69 kV line leaves loads south of Jordan devoid of any strong source from the north. This also causes near-term low voltages and thermal loading violations in the study area.

The transmission system in the study area mostly serves agricultural and residential customers with some industrial loads located in the Gifford Lake area. The affected load areas include Assumption, Belle Plaine, Gifford Lake, Merriam Junction, Jordan, Sand Creek, New Prague, Veseli, French Lake, and Waseca The study area consists of several other loads as listed in Section 3.2.

Major transmission projects around the study area include the CapX 2020 Brookings County-Hampton 345 kV project, Sheas Lake 345/115/69 kV project, and Highway 212 corridor projects. The completion of these projects will increase reliability throughout southwest and west central Minnesota, including the Twin Cities. As these projects are in close proximity to the transmission system in the study area, they present alternatives for interconnection to the 69 kV system serving the study area. The study area could also benefit from the future Sheas Lake and Chub Lake 345/115 kV substations, which are located to the west and east of the study area, respectively.

Generation in the study area is in short supply. Currently, there is not enough generation in the study area that can be used to address the needs of the transmission system over the long term. There is only one generation site, which is located at New Prague Municipal. Running this generation to address the needs of the area is costly and will not be sufficient to mitigate the long-term load serving needs of the study area.

### 3. Models and Study Assumptions

The general study area is historically a summer peaking area, and therefore the MRO 2010 series 2012 and 2016 Summer Peak models were chosen to perform the study. The assumption is that the 2012 Summer Peak model will show the existing system performance while the 2016 Summer Peak model will provide information on the system performance as loads in the study area grow. These study models have been modified to reflect the following changes/assumptions:-

1. Highway 212 corridor project, which constructs a 115 kV line between West Waconia breaker station and Scott County substation, was included in the base model to alleviate the Scott County transformer overload;
2. The Arlington Carver County rebuild project was also included along with the proposed „Normally Open’ switches;
3. The 69 kV line between Steele Waseca River Point and County Line (Alliant) was opened as the switch 6056 near County Line substation is operated normally open;
4. The summer normal and emergency rating of Waseca to Loon Lake 69 kV line, in the model, is given as 56.7 and 65.9 MVA respectively, whereas the actual rating of the line is 66.6 and 71.1 MVA respectively. This is due to jumper uprate at Loon Lake;
5. The summer emergency rating of Penelope tap to Traverse 69 kV line section is updated to 80 MVA;
6. The impedance of the New Prague to New Prague tap 69 kV line was corrected;
7. The summer normal and emergency rating of Jamestown to Jamestown tap 69 kV line section is updated to 45.4 MVA;
8. The summer emergency rating of Eagle Lake to GRE Eagle Lake is updated to 100 MVA, to reflect the switch upgrade. (4S316);
9. The summer emergency rating of Eagle Lake to James tap is updated to 100 MVA, to reflect the switch upgrade (4S317);
10. The MNTACT 2010 Contingency files were used to run the ACCC analysis;
11. The generators in St Peter (SMMPA) were turned off in all study models to stress the system further;
12. Corrections to the double counting of the Shakopee load were made. This change has been highlighted in the detail loads in the Appendix B;
13. Brooking County – Hampton 345 kV project was included in the out-year model;

### 3.1 Study Criteria

The study will identify solutions to address NERC reliability standards, mainly Category A and B criteria, and the MRO TPL-503-MRO-01 reliability standards. The NERC Category C and D violations will be addressed under a larger study called Minnesota Transmission Assessment and Compliance Team (MNTACT). The following criteria in tables 3.1 and 3.2 were used to monitor the transmission system for any low voltage or overload concerns.

**Table 3.1 Voltage Criteria at Load Serving Buses**

Transmission System	System Intact		Contingency	
	Minimum Voltage (p.u)	Maximum Voltage (p.u)	Minimum Voltage (p.u)	Maximum Voltage (p.u)
NSP and GRE	0.95	1.05	0.92	1.10
ITC	0.95	1.05	0.93	1.10
SMMPA	0.95	1.05	0.90	1.10

**Table 3.2 Thermal Loading Criteria**

Transmission System	Lines		Transformers	
	Normal (Continues )	Emergency (30 minute)	Normal (Continues )	Emergency (30 minute)
NSP	100 %	110 %	100 %	125 %
GRE	100 %	100 %	100 %	125%
ITCM	100%	100%	100%	100%
SMMPA	100%	110%	100%	125%

### 3.2 Study Area Loads

Loads in the study models were modified so that the transmission system serves the projected maximum demand for the respective year. The maximum historical peak load of each substations in the affected load area was used as a start load for current year model, 2012 SUPK model. These loads were then grown based on the projected average annual load growth percentage to get the loads levels for the out-year model, 2016 SUPK model. The following tables (3.3 to 3.6) show the projected loads and the applied growth rates that were used in the study.

**Table 3.3: GRE Member Cooperative Loads**

SUBSTATIONS	SUPK NCP - 2012		Growth Rate	SUPK NCP -2016	
	MW	MVA <sub>r</sub>		MW	MVA <sub>r</sub>
New Prague	7.719	1.567	3.00%	8.69	1.76
Merriam Junction	6.538	1.328	1.50%	8.94	1.82
Prior Lake North	11.078	2.249	2.00%	11.99	2.43
Assumption	2.455	0.499	3.00%	2.76	0.56
New Market	4.122	0.837	2.00%	4.46	0.91
Spring Lake	5.789	1.176	3.00%	6.52	1.32
Gifford Lake	3.653	0.742	2.00%	3.95	0.80
Elko	10.974	2.228	7.00%	14.38	2.92
Cleary Lake	11.216	2.278	5.00%	13.63	2.77
Sand Creek	5.148	1.045	3.00%	5.79	1.18
Prior Lake South	15.429	3.133	2.00%	16.70	3.39
French Lake	2.750	0.558	3.00%	3.10	0.63

**Table 3.4: SMMPA Loads**

Load	SUPK NCP - 2012		Growth Rate	SUPK NCP -2016	
	MW	MVA <sub>r</sub>		MW	MVA <sub>r</sub>
New Prague Muni 2	8.6	1.74	0.8 %	8.9	1.82
New Prague Muni 1	4.6	0.94	0.8 %	4.8	0.98

**Table 3.5: ITCM/Alliant Energy Loads**

Load	SUPK NCP - 2012		Growth Rate	SUPK NCP -2016	
	MW	MVA <sub>r</sub>		MW	MVA <sub>r</sub>
Montgomery	8.5	2.5	0.25 %	8.6	2.5

**Table 3.6: Xcel Energy Loads**

Load	SUPK NCP - 2012		Growth Rate	SUPK NCP -2016	
	MW	MVA <sub>r</sub>		MW	MVA <sub>r</sub>
Credit River	17.14	3.48	1%	19.0	3.858
Veseli	6.072	1.233	1%	6.250	1.269
Jordan	9.488	1.927	1%	9.770	1.984
Belle Plaine	15.889	3.226	1%	16.370	3.324

The affected areas shown in the table are mostly served by Minnesota Valley Electric Cooperative, a member of Great River Energy, distribution substations. For purposes of studying the transmission system and monitoring load growth, distribution substation data are used to calculate and forecast load. These distribution substations are closer to the load than bulk substations and the data from distribution substations are more reflective of load patterns. Loads in the study area, as in most other areas, did not show a significant load growth in the years between 2007 and 2009 as shown in the plots below. The reduction in the load growth between these years is attributed to the slowdown of the economy.

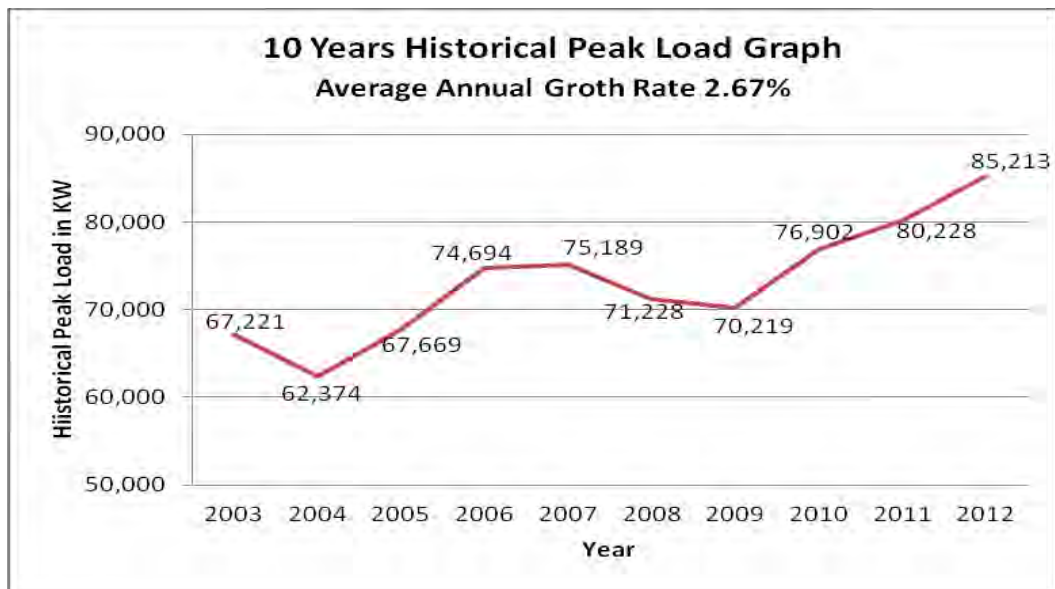

**Figure 3.1: GRE load in the Affected Area 10 years historical load growth graph**

The plot shows the total load in the affected area per year plotted based on 10 years worth of historical data. As the plot shows the 10 year average annual growth rate of the area was just under 2.7%. With the projected spot loads in the area taken in to consideration, the last five years growth rate in the area is most descriptive of the near-term load growth trend in the affected area. The plot below shows the historical load growth trend in the affected area for the last 5-years.

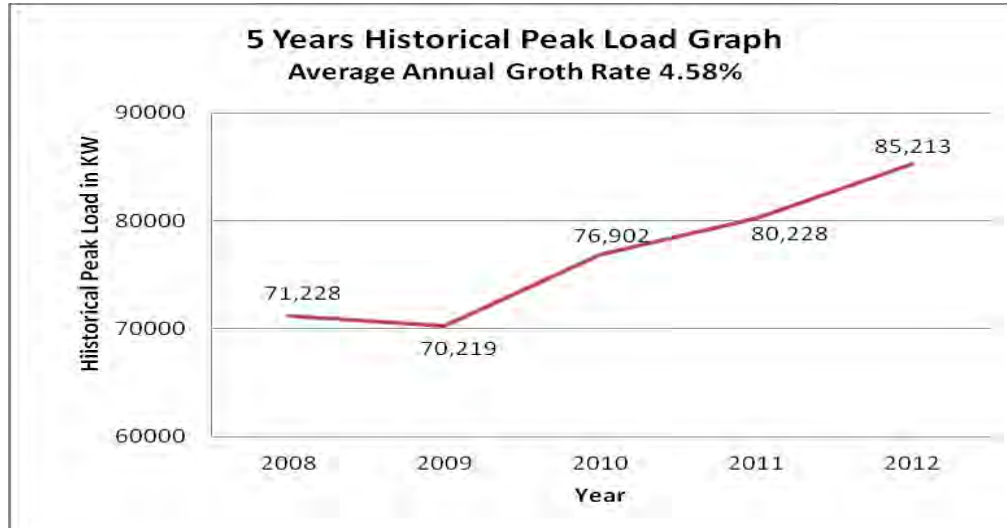

**Figure 3.2: GRE load in the Affected Area 5 years historical load growth graph**

The historical load plots show that there has been a consistent growth over the last four years after the slowdown between the years 2007 and 2009. The historical average annual growth percentage over this period in the affected area is calculated to be just under 4.6%. The weighted average, 3.26%, of the growth rate percentages used for GRE loads when projected from the 2012 load level to the 2016 load level, Table 3.3, is between the ten and five year growth rates.

Xcel Energy has the second most substations serving loads in the affected load area. A load growth rate of 1% was used to grow loads served by Xcel Energy from the 2012 load level to the 2016 load level. The historical ten year and five year historical loads are plotted as follows.

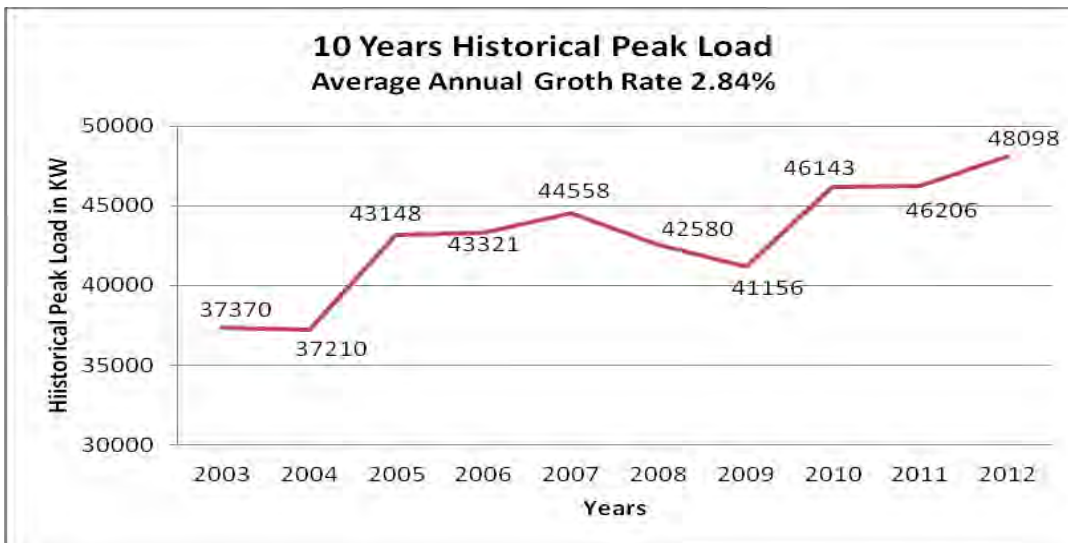

**Figure 3.3: Xcel Energy load in the Affected Area 10-year historical load growth graph**

The average ten-year annual historical load growth was calculated to be 2.84 % and the average five years annual historical load growth was calculated to be about 3.1% as shown in the plot below. The load growth trend is similar with GRE’s where the growth in the area only slowed down between years 2007 and 2009. This is attributed to the slow down or uncertainties in the economy between those years. In general, a consistent and significant amount of load growth is recorded in the area.

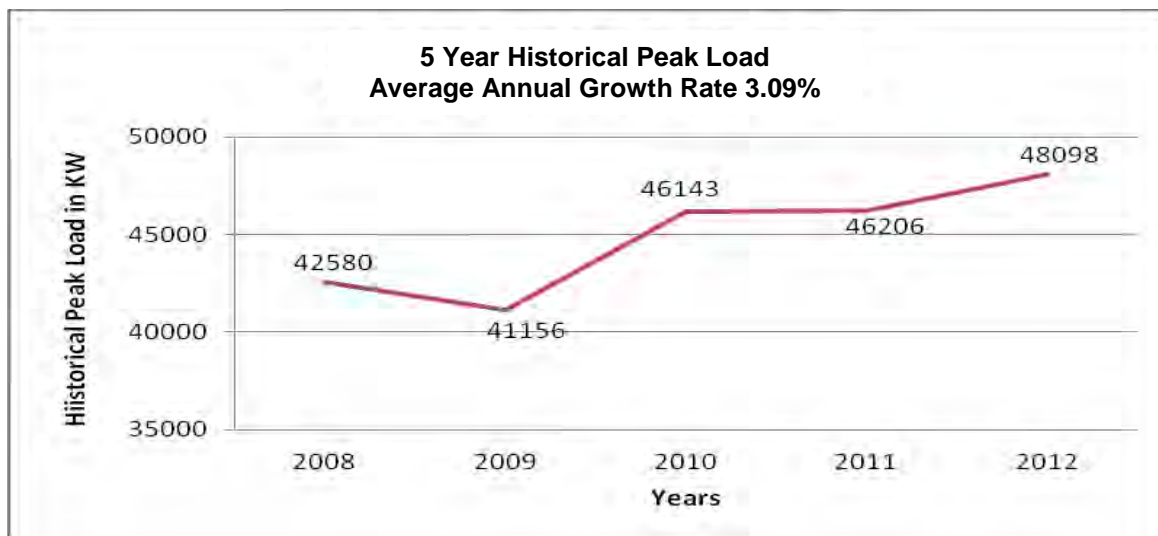
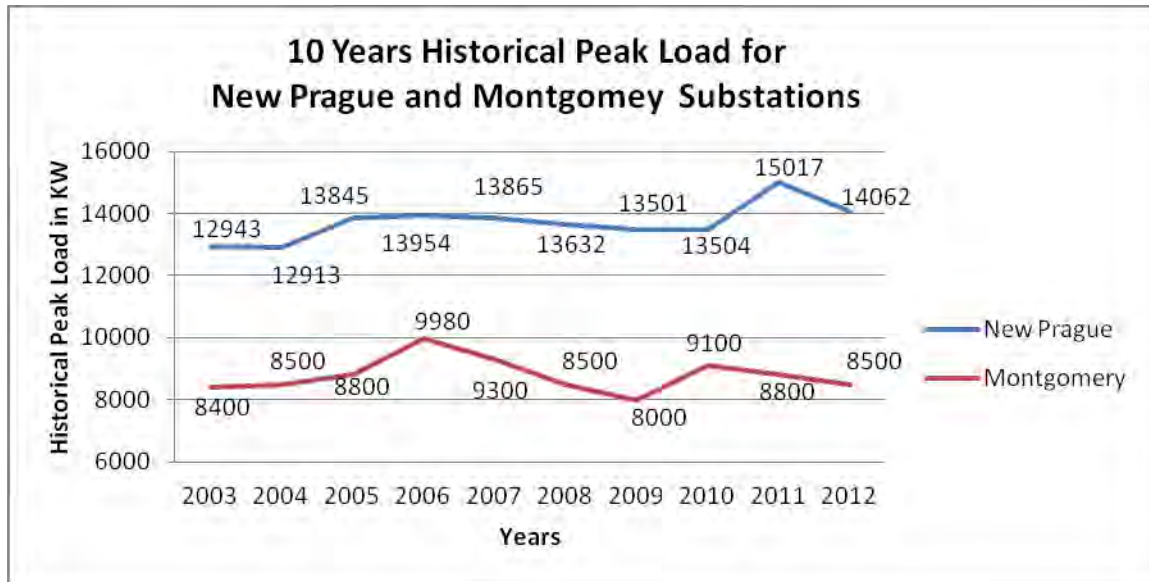

**Figure 3.4: Xcel Energy load in the Affected Area 5-year historical load growth graph**

SMMPA and Alliant Energy serve the area in the cities of New Prague and Montgomery, respectively. The historical peak load plot for the two substation loads show that the growth



rate is flat. The ten year historical average load growth percentage for New Prague is just under 1%, 0.93%, and for Montgomery just over 0%, 0.13%. Although the growth rates at these substations are not significant, the two substations serve stable loads.



**Figure 3.5: ITCM and SMMPA loads in the Affected Area 10-year historical load growth graph**

As the study area is continually monitored for any transmission deficiencies, any transmission concerns as a result of, for example, large spot loads or faster than projected load growth in the study area, will be identified and addressed promptly. Historical loads of the study area are documented in Appendix A of this report.

## 4. Analysis

### 4.1 Existing System Condition (2012)

The study area load is supported by Scott County and Carver County sources in the north. The Scott County 115/69 kV substation is the stronger source in the area due to newly rebuilt lines and relatively lower impedance conductor that links the substation to the study area. Sources to the study area from the south, (i.e. the Owatanna 161/69 kV and Loon Lake 115/69 kV sources) provide weak support to the study area due to the high impedance conductor that links these sources to the study area and that these sources are located at a distant from the load center of the study area. A study of the existing system, based on the 2012 summer peak model, was performed to identify any voltage or equipment loading violations in the existing transmission system with the current year (2012) load profile. Figure 4.1 is the one-line of the existing transmission system in the study area.

**Figure 4.1: Existing System One-line diagram**

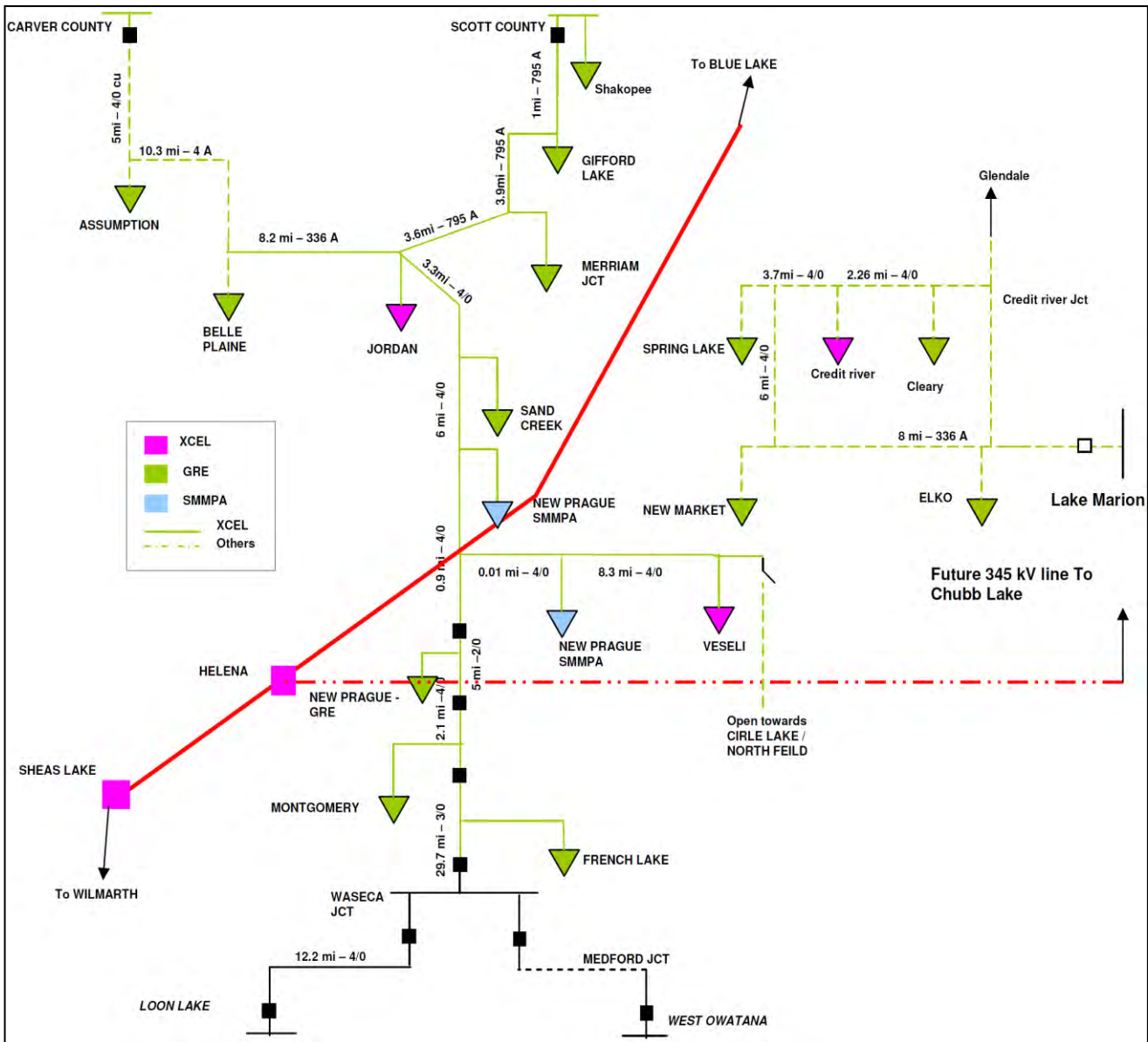

The study found that the existing transmission system does not exhibit low voltage or transmission line overload concerns during system intact conditions. However, transmission line outages cause low voltage and transmission line overload concerns in the study area. Some of the contingencies that cause low voltage problems include the loss of the Scott County to Gifford Lake 69 kV line, loss of Gifford Lake to Merriam Junction 69 kV line and loss of Jordan to Sand Creek 69 kV line. Areas which experience low voltage concerns upon any of these transmission line outages include Gifford Lake, Merriam Junction, Jordan, Sand Creek, New Prague, Veseli, Montgomery, and French Lake.

The table below shows a shortened list of transmission line outages and the respective low voltage concerns they cause. A longer and complete version of this table is provided in Appendix C.

**Table 4.1: 2012 Load Level Low Voltage Concerns**

CONTINGENCY	SUBSTATION NAME	KV	OWNER	VOLAGE%	DROP%
New Prague to Sand Creek 69 kV line outage	Veseli	69.0	600	75.11	21.1
	New Prague Muni -1	69.0	600	76.14	20.86
	New Prague Muni 2	69.0	613	75.13	22.78
	French Lake	69.0	615	86.35	12.19
	Montgomery	69.0	627	80.16	17.59
	GRE New Prague	69.0	627	76.93	20.18
Jordan to Sand Creek 69 kV line outage	Veseli	69.0	600	56.4	39.81
	New Prague Muni -1	69.0	600	57.5	39.5
	New Prague Muni -2	69.0	613	55	42.91
	French Lake	69.0	615	64.7	33.04
	Montgomery	69.0	627	53.9	44.9
	GRE New Prague	69.0	627	76.6	21.94
Scott County to Gifford Lake 69 kV line outage	Veseli	69.0	600	85.23	10.98
	Jordan	69.0	600	86.74	13.29
	Belle Plaine	69.0	600	89.13	10.32
	New Prague Muni -1	69.0	613	86.02	10.91
	New Prague Muni 2	69.0	613	85.8	12.11
	Gifford Lake	69.0	615	86.4	15.12
	Sand Creek	69.0	615	85.94	12.86
	Merriam Junction	69.0	615	86.5	14.17
	Montgomery	69.0	627	88.66	9.08
	GRE New Prague	69.0	627	86.62	10.49
Gifford Lake to Merriam Junction 69 kV line outage	Veseli	69.0	600	86.62	9.58
	Jordan	69.0	600	88.38	11.65
	Belle Plaine	69.0	600	90.45	9
	New Prague Muni -1	69.0	613	87.4	9.53
	New Prague Muni 2	69.0	613	87.31	10.6
	Sand Creek	69.0	615	87.54	11.26
	Merriam Junction	69.0	615	88.23	12.43
	French Lake	69.0	615	93.06	5.48
	Montgomery	69.0	627	89.82	7.92
	GRE New Prague	69.0	627	87.95	9.16

As the table shows, voltages at load serving buses are below the required minimum voltage criteria of 92% during certain outages. The following one-line diagrams provide a graphical representation of contingencies and the inadequacies the system experiences. The contingencies listed in Table 4.1 were chosen for graphical presentation in this report. One-line diagrams showing the contingencies and inadequacies are included in Appendix H.

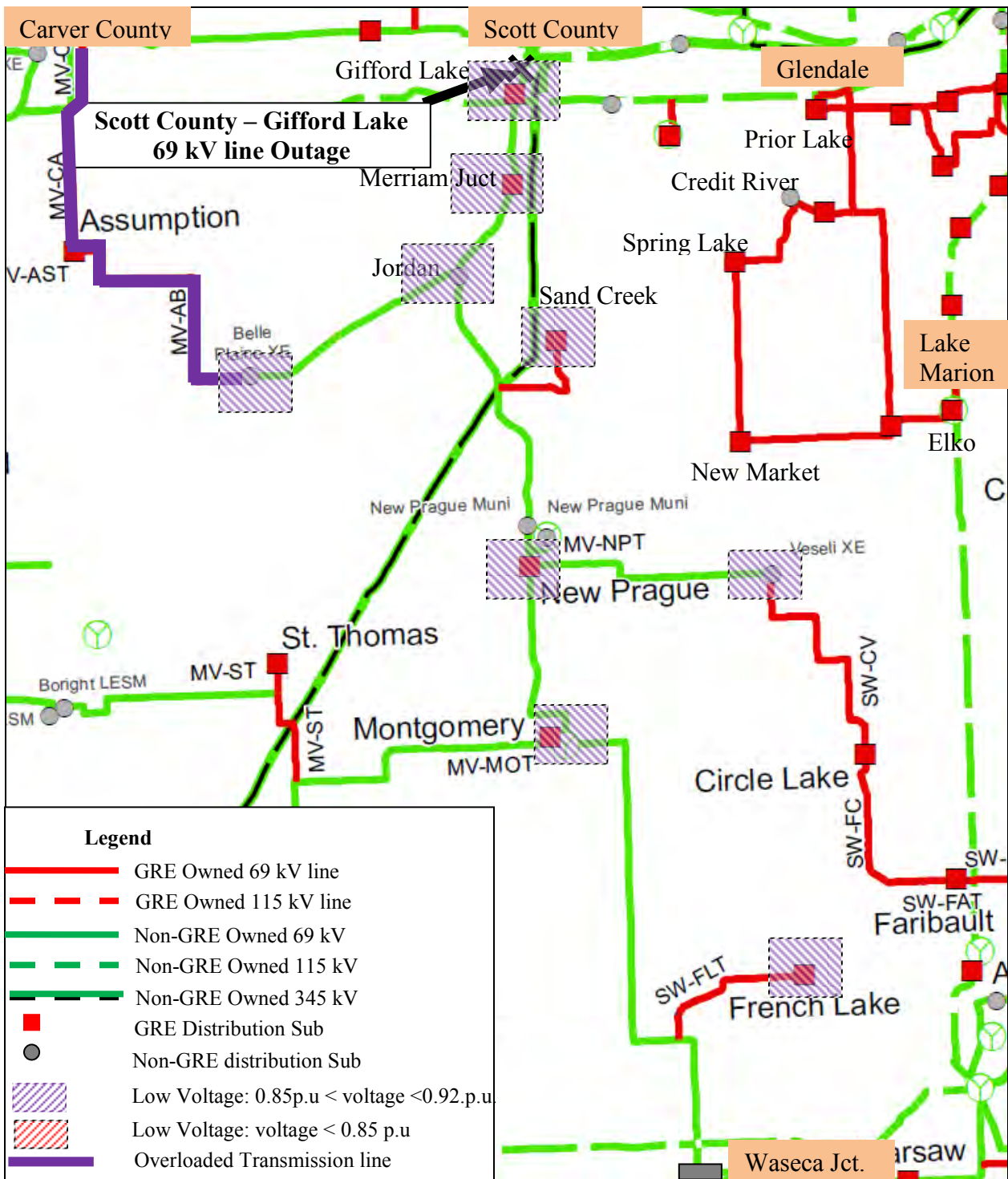
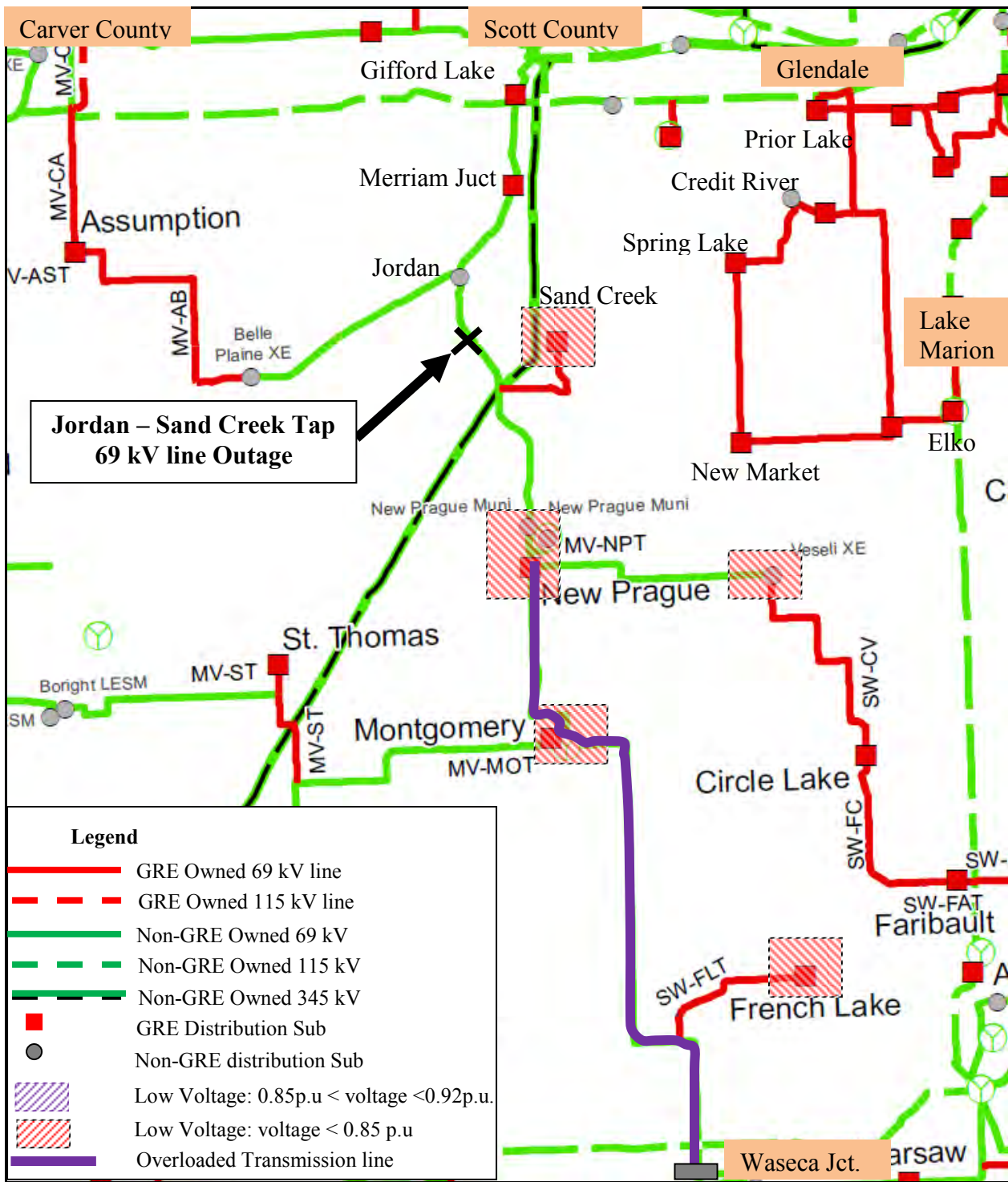

Figure 4.2: Scott County to Gifford Lake 69 kV line Outage – 2012



**Figure 4.3: Jordan to Sand Creek 69 kV line Outage – 2012**

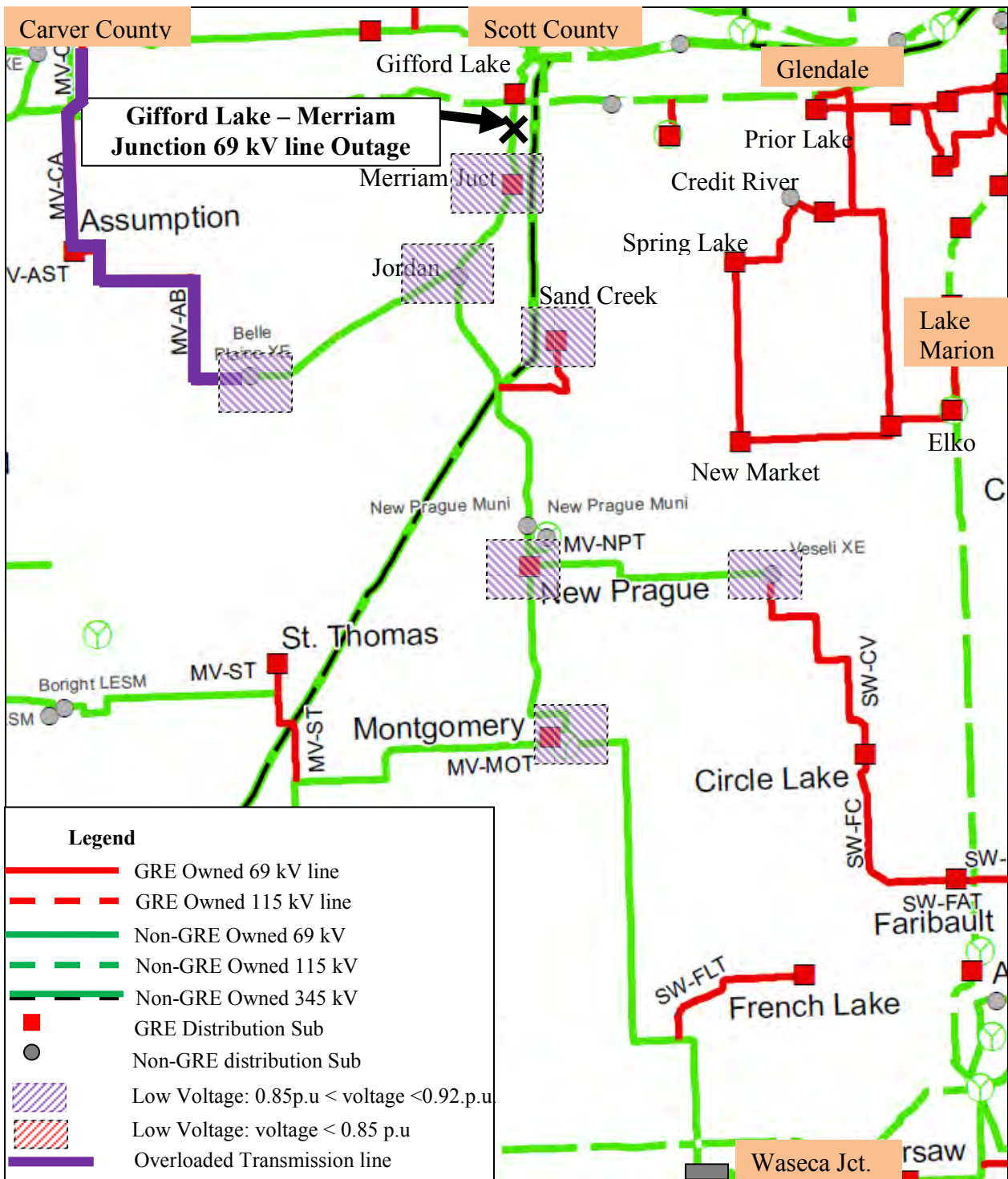
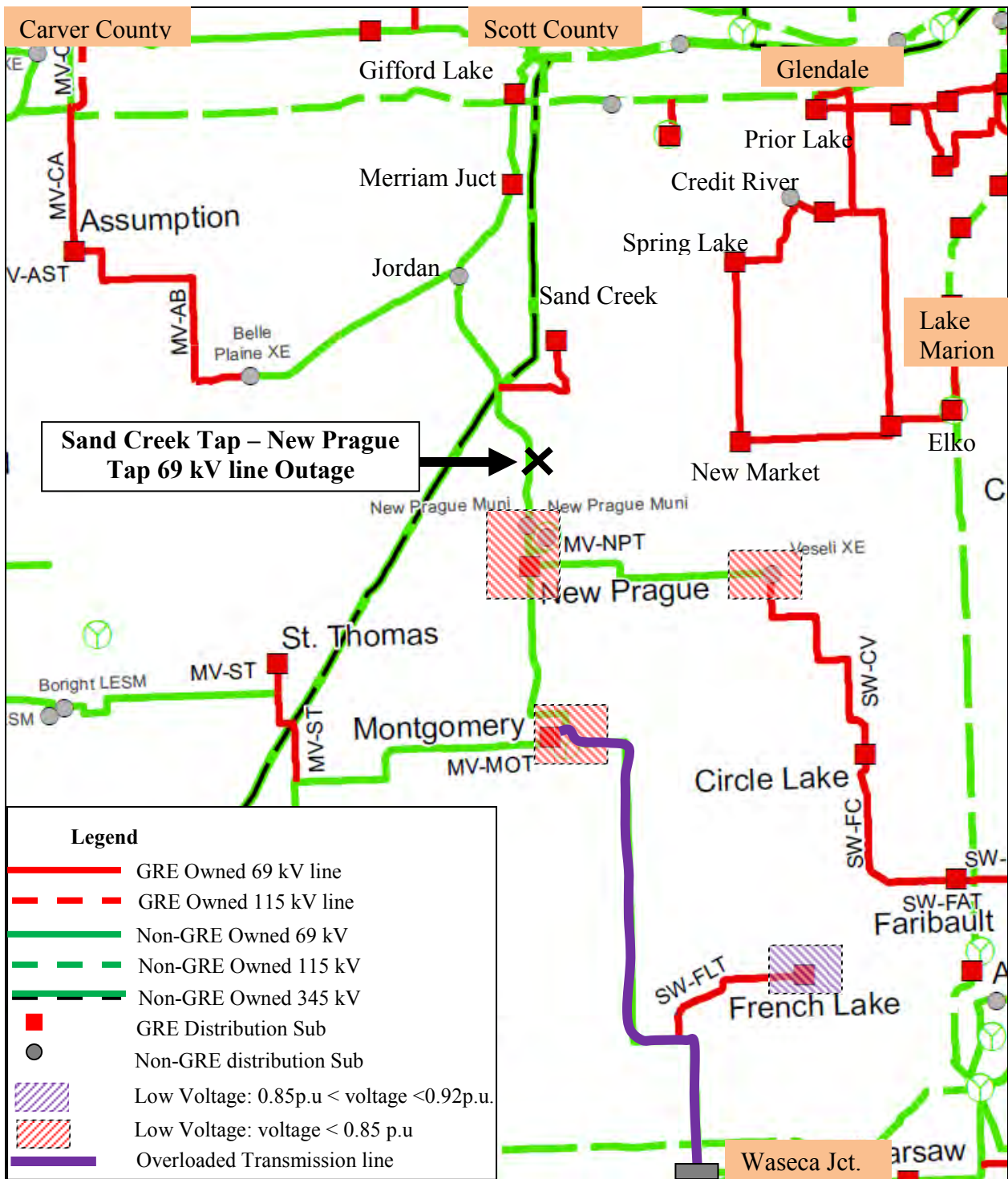

Figure 4.4: Gifford Lake to Merriam Junction 69 kV line Outage – 2012



**Figure 4.5: Sand Creek to New Prague 69 kV line Outage – 2012**

In addition to the low voltage concerns, these transmission line outages were also found to cause transmission line overload concerns in the study area. The transmission lines that experience overload concerns include the Carver County – Assumption 69 kV line, Assumption – Belle Plaine 69 kV line, Sand Creek Tap – New Prague Tap 69 kV line and others listed in Table 4.2 below. Table 4.2 shows selected transmission line overloads and the contingencies that caused the overload. The geographical representations above and one-line Appendix H

New Prague Area Load Serving Study

diagrams in Appendix H show the line overloads as a result of contingencies listed in Table 4.1 and Table 4.2. The complete list of transmission line overload concerns and the corresponding transmission line outages are tabulated in Appendix C.

**Table 4.2: 2012 Load Level: Transmission Line Overloads**

<b>Branch Circuit</b>	<b>Cont MVA</b>	<b>Rating</b>	<b>Loading% I- MVA</b>	<b>Contingency Description</b>
French Lake Tap to Waseca Junction 69 kV line	49.9	36.0	181	Jordan to Sand Creek 69 kV line
Carver County to Assumption 69 kV line	59.9	45.4	129.8	Scott County to Gifford Lake 69 kV line
Assumption to Belle Plaine	50.3	45.4	124.3	Scott County to Gifford Lake 69 kV line
Carver County to Assumption 69 kV line	55.9	45.4	120.9	Gifford Lake to Merriam Junction 69 kV line
Assumption to Belle Plaine	47.4	45.4	115.4	Gifford Lake to Merriam Junction 69 kV line
French Lake Tap to Montgomery 69 kV line	39.8	36.0	171	Jordan to Sand Creek 69 kV line
Montgomery to New Prague Tap	33.2	36.0	142.2	Jordan to Sand Creek 69 kV line

These overloaded transmission lines consist of 4/0A or smaller size conductors, which have high impedance, low capacity, and are aging. Loads served on these transmission lines have grown and new services have been added over the years causing the lines to reach to their maximum current carrying capability. The high impedance characteristics of these transmission lines have also been a source of low voltage concern at Gifford Lake and Merriam Junction during a contingency, such as the Carver County to Gifford 69 kV line outage, Gifford Lake – Merriam Junction 69 kV line outage and other outages. Rebuilding certain transmission lines such as the Carver County to Assumption and Assumption to Belle Plaine 69 kV lines with 795ACSS conductor would address the line overload concerns on the Carver County to Belle Plain 69 kV line and alleviate the low voltage problems at Gifford Lake, Jordan and Merriam Junction substations during contingencies. This line rebuild, however, does not address the transmission line overload concern on the Waseca Junction to New Prague 69 kV line and the low voltage problems at Sand Creek, New Prague, New Prague Muni, Veseli and French Lake. Therefore, other best value solutions, which may involve the line rebuild of the Carver County to Belle Plaine 69 kV line must be devised to address the inadequacies in the system.



## 4.2 Future System Conditions (2016)

A study using the out-year model, 2016 Summer Peak model, was performed to examine the impacts of proposed projects near the study area as well as how the existing system performs as load grows. The proposed projects in the proximity of the study area such as the Highways 212 corridor project, Glencoe to West Waconia 115 kV project, Arlington to Carver County 69 kV line rebuild project, and the CapX Brooking County to Hampton 345 kV line project were included in the study model. The analyses show that the transmission system will experience severe low voltage and transmission line overload concern in the near future, as shown in the tables below. These proposed projects were found to have little to no impact on alleviating either the transmission line overload or low voltage concerns in the study area. Therefore, additional improvements to the transmission system that serve the study area are required to continue to serve existing, new and growing loads in the area.

Some of the areas experiencing severe low voltage concerns during contingencies include Gifford Lake, Merriam Junction, Jordan, Sand Creek, New Prague, Veseli and French Lake. Table 4.3 below shows the worst case voltage violations. Complete list of low voltage concern for the out-year case (future condition) is included in Appendix C.

**Table 4.3: 2016 Load Level Low Voltage Concerns**

CONTINGENCY	SUBSTATION NAME	KV	OWNER	VOLAGE%	DROP%
Jordan to Sand Creek Tap 69 kV line outage	Veseli	69.0	600	50.15	46.58
	New Prague Muni 1	69.0	613	51.19	46.28
	New Prague Muni 2	69.0	613	51.09	46.58
	Sand Creek	69.0	615	49.41	49.71
	French Lake	69.0	615	72.66	26.62
	Montgomery	69.0	627	59.25	39.1
	GRE New Prague	69.0	627	52.93	44.71
New Prague to Sand Creek Tap 69 kV line outage	Veseli	69.0	600	68.83	27.89
	New Prague Muni 1	69.0	613	69.78	27.68
	New Prague Muni 2	69.0	613	69.84	27.83
	French Lake	69.0	615	82.98	16.3
	Montgomery	69.0	627	74.94	23.4
	GRE New Prague	69.0	627	70.92	26.72
Gifford Lake to Merriam Junction 69 kV line outage	Veseli	69.0	600	84.45	12.27
	Jordan	69.0	600	86.69	13.79
	Belle Plaine	69.0	600	89.17	10.95
	New Prague Muni 1	69.0	613	85.27	12.2
	New Prague Muni 2	69.0	613	85.36	12.31
	Sand Creek	69.0	615	85.75	13.37
	Merriam Junction	69.0	615	86.47	14.56
	Montgomery	69.0	627	88.17	10.17
GRE New Prague	69.0	627	85.91	11.73	

CONTINGENCY	SUBSTATION NAME	KV	OWNER	VOLAGE%	DROP%
Scott County to Gifford Lake 69 kV line outage1	Veseli	69.0	600	83.01	13.71
	Jordan	69.0	600	85.14	15.34
	Belle Plaine	69.0	600	88.02	12.11
	New Prague Muni 1	69.0	613	83.83	13.63
	New Prague Muni 2	69.0	613	83.92	13.75
	Gifford Lake	69.0	615	84.72	17.15
	Sand Creek	69.0	615	84.23	14.89
	Merriam Junction	69.0	615	84.82	16.21
	French Lake	69.0	615	91.37	7.9
	Montgomery	69.0	627	86.96	11.39
GRE New Prague	69.0	627	84.53	13.12	

Table 4.4 below shows, multiple lines in the area will experience overload problems during contingencies. A complete list of overloaded transmission lines and the corresponding contingencies are included in Appendix C.

**Table 4.4: 2016 Load Level: Transmission Line Overloads**

Branch	CONT RATE MVA	LOADG %I	CURRENT MVA	CONTINGENCY
Jordan to Sand Creek Tap 69 kV line	48.0	53.1 102.4	25.51 49.17	SYSTEM INTACT 619633 GRE-FRLK TP869630133 WASECAJ8 691
Belle Plaine to Assumption 69 kV line	45.4	37.9 101.8 132.4 122.5	17.19 46.19 60.11 55.62	SYSTEM INTACT 605142 JORDAN 8 69618733 GRE-MERRIAM8691 605244 SCOTTCO8 69618716 GRE-GIFFDLK869 1 618716 GRE-GIFFDLK869 618733 GRE-MERRIAM869
Carver County – Assumption 69 kV line	45.4	43.9 108 138.7 128.8	19.91 49.02 62.96 58.47	SYSTEM INTACT 605142 JORDAN 8 69 618733 GRE-MERRIAM869 1 605244 SCOTTCO8 69 618716 GRE-GIFFDLK869 1 618716 GRE-GIFFDLK869 618733 GRE-MERRIAM869
New Prague Muni 1 to New Prague Muni Tap 69 KV line	35.0	7.2 121.1	2.52 42.39	SYSTEM INTACT 605142 JORDAN 8 69 618717 GRE-SNDCRKT869
French Lake Tap to Waseca Junction 69 kV line	36.0	59.5 199.3 107.6 111.9 150.6 102.8	21.41 71.75 38.74 40.27 54.23 37.02	SYSTEM INTACT 605142 JORDAN 8 69 618717 GRE-SNDCRKT869 605244 SCOTTCO8 69 618716 GRE-GIFFDLK869 1 605280 NPR TAP8 69 613200 NEWPRAGN 69 1 613200 NEWPRAGN 69 618717 GRE-SNDCRKT869 618716 GRE-GIFFDLK869 618733 GRE-MERRIAM869
French Lake Tap to Montgomery 69 kV line	36.0	51.2 187.7 102.6 140.2	18.43 67.56 36.93 50.46	SYSTEM INTACT 605142 JORDAN 8 69 618717 GRE-SNDCRKT869 605280 NPR TAP8 69 613200 NEWPRAGN 69 1 613200 NEWPRAGN 69 618717 GRE-SNDCRKT869
Montgomery to GRE New Prague 69 KV line	36.0	28.3 156.5 113.6	10.18 56.35 40.88	SYSTEM INTACT 605142 JORDAN 8 69 618717 GRE-SNDCRKT869 613200 NEWPRAGN 69 618717 GRE-SNDCRKT869

Of the multiple transmission line outages that cause low voltage and transmission line overload concerns in the study area, the Carver County to Gifford Lake, Gifford Lake to Merriam Junction, Jordan to Sand Creek and Sand Creek to New Prague 69 kV line outages Appendix H New Prague Area Load Serving Study 18

were chosen to graphically illustrate the concerns in the transmission system. Figure 4.5 shows that the Scott County to Gifford Lake 69 kV line outage causes low voltage problems at a number substations in addition to line overload concern on the Scott County to Assumption 69 kV line, Assumption to Belle Plaine 69 kV line and Waseca Junction to French Lake Tap 69 kV line. The loss of Jordan to Sand Creek Tap 69 kV line, as shown in Figure 4.6, causes several low voltage problems at multiple substations and overload concerns on multiple sections of the transmission system between Waseca Junction and New Prague Municipal Tap. A one-line diagram showing the voltage and overload levels during these contingencies are included in Appendix H.

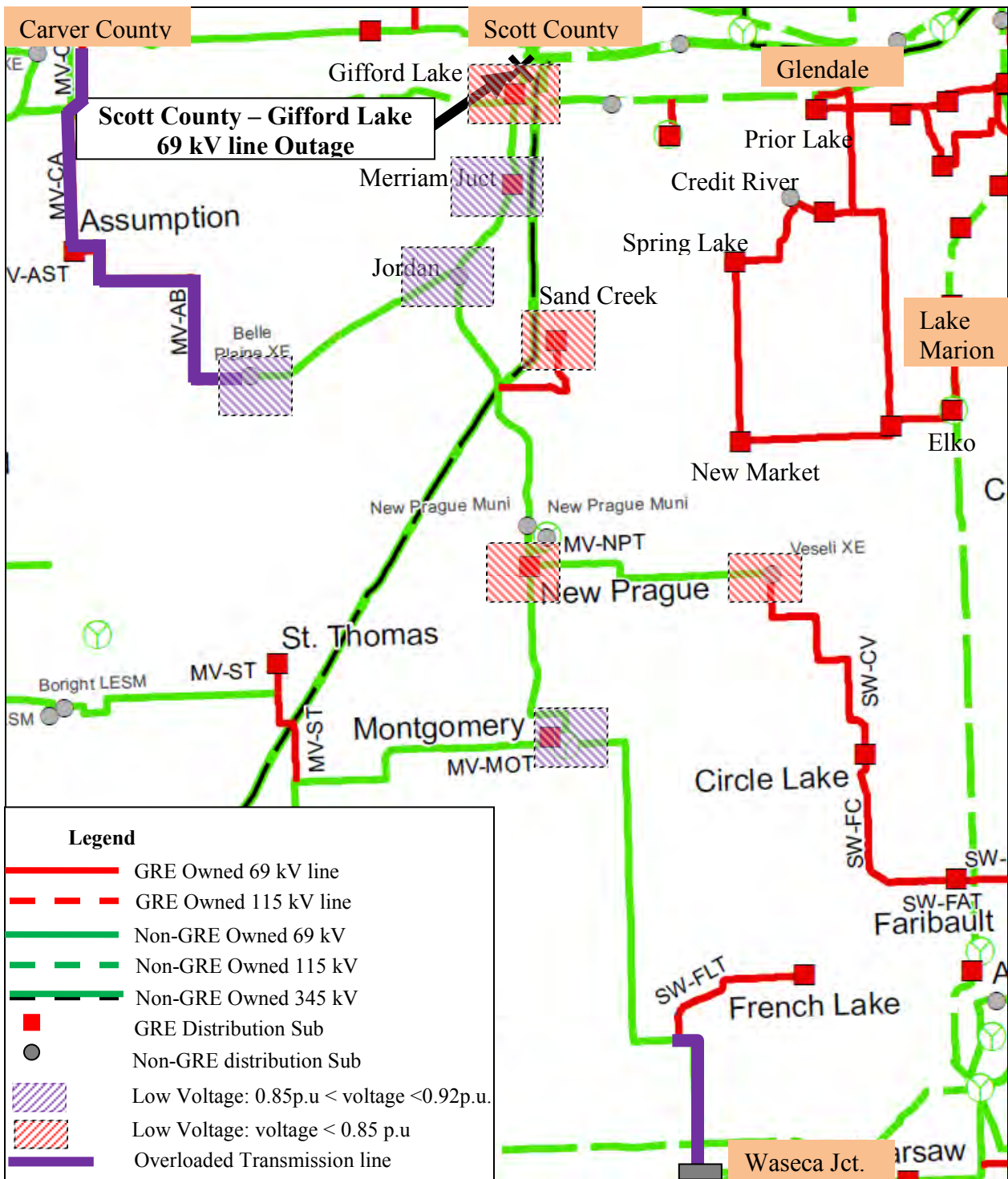
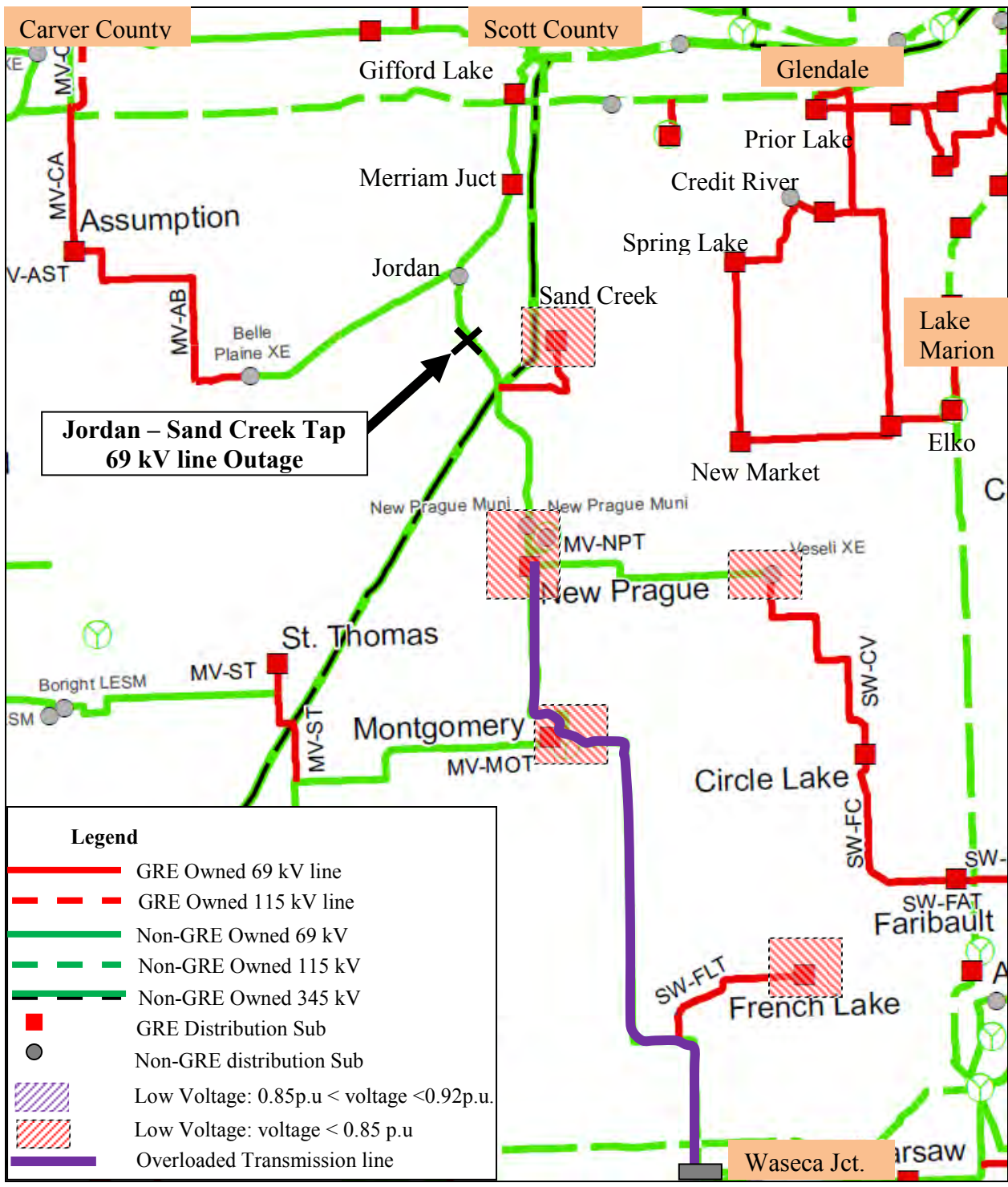

Figure 4.5: Scott County to Gifford Lake 69 kV line Outage – 2016



**Figure 4.6: Jordan to Sand Creek 69 kV line Outage – 2016**

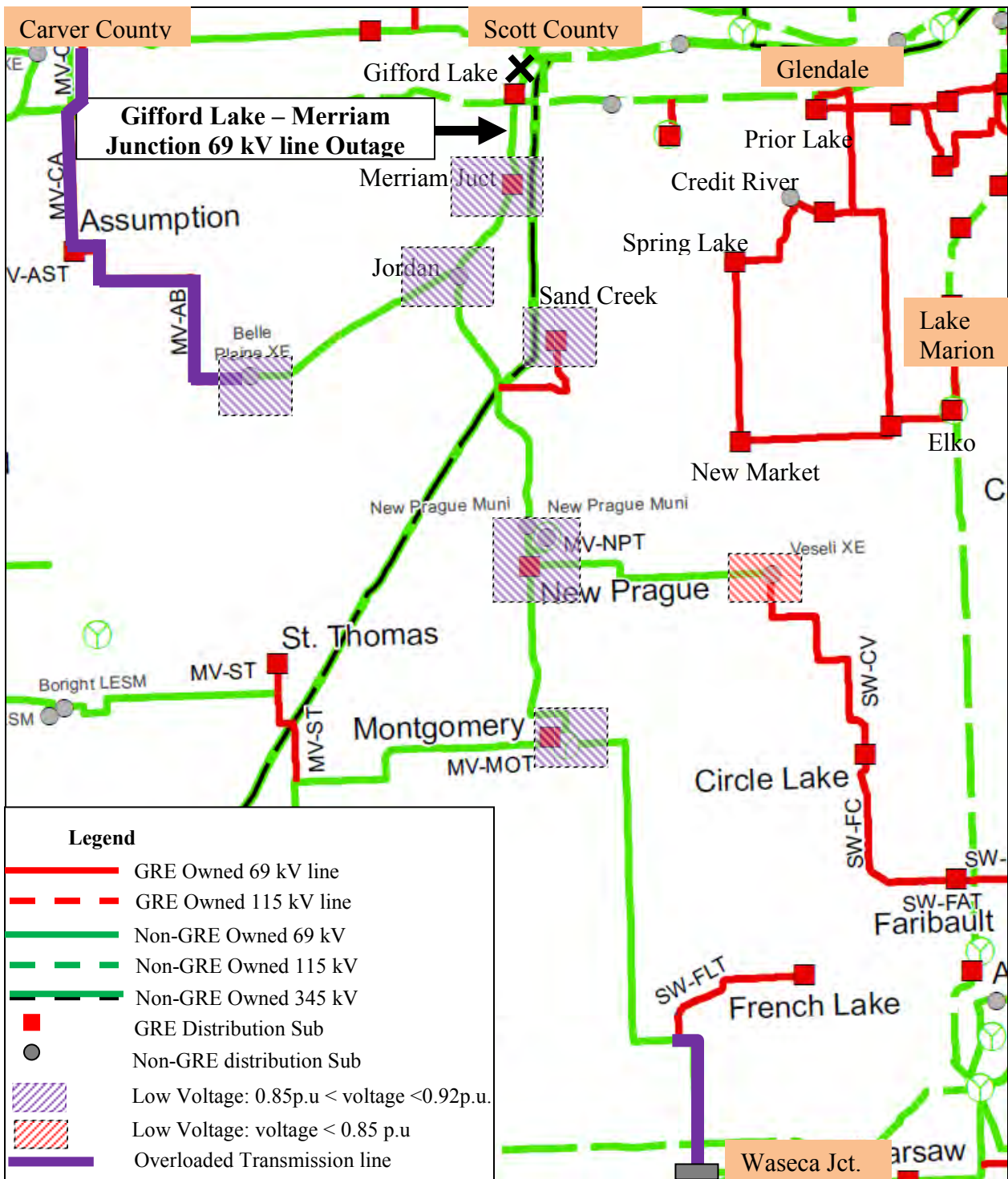
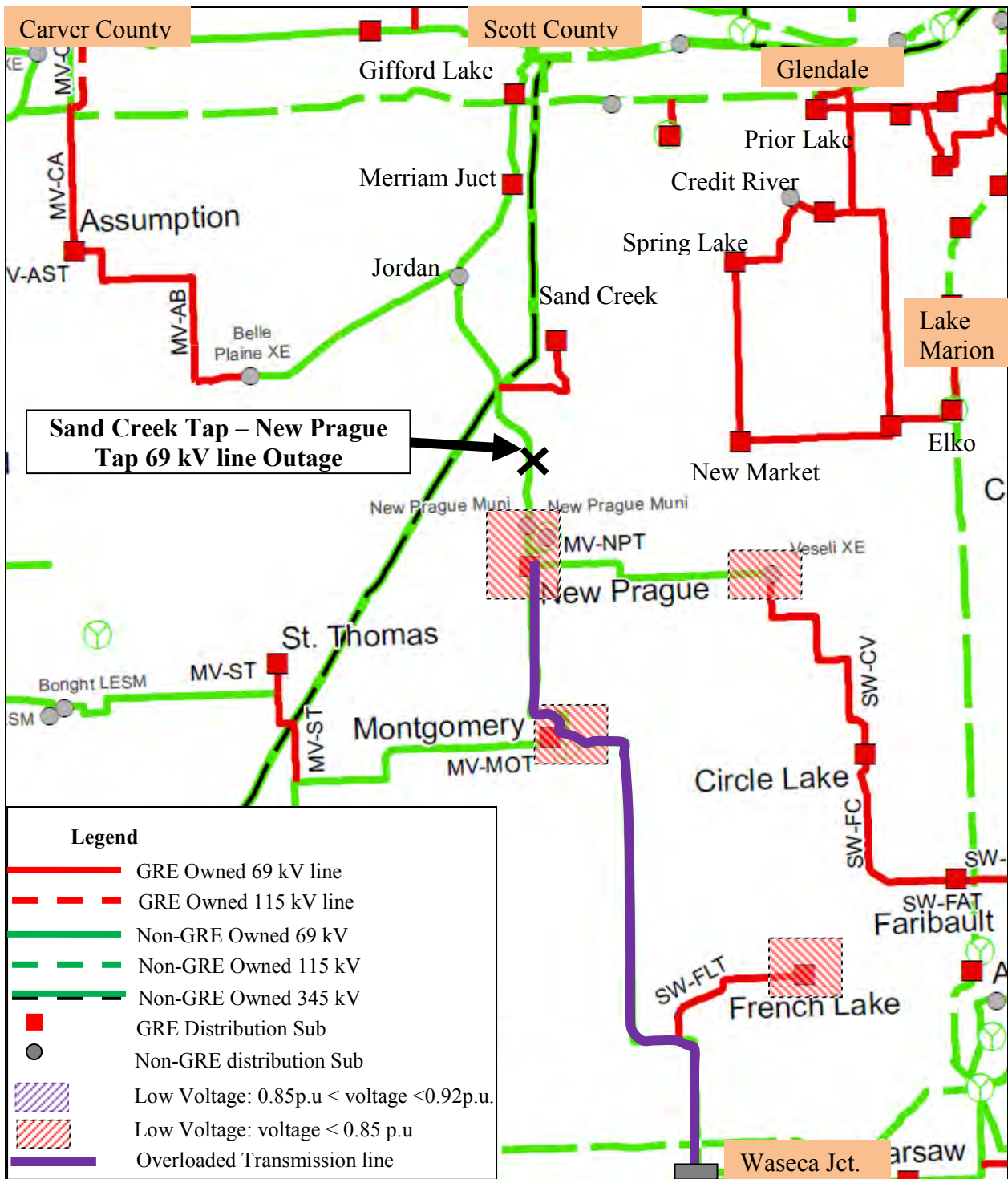

Figure 4.7: Gifford Lake to Merriam Junction 69 kV line Outage – 2016



**Figure 4.8: Sand Creek Tap to New Prague Tap 69 kV line Outage – 2016**

Note that the legend in the figures show voltage levels below 0.85 per unit and between 0.85 per unit and 0.92 per unit in different colors to differentiate the severity of the low voltages during different cases. The actual values of the low voltage and overload levels are shown on the one-line diagrams in Appendix H.

The analyses showed that the already proposed projects in the area do not improve service to the study area significantly under contingency conditions. The transmission deficiencies, both Appendix H New Prague Area Load Serving Study 23

low voltage and thermal loading concerns, in the study area are limited to the long and high impedance 69 kV network that is generally fed by the Carver County, Scott County, Loon Lake and Owatanna sources. The planned projects strengthen the 115 kV system that are sources to the study area; however, these sources are electrically too far from the load center to address low voltage problems in the area during contingencies. In addition, the 69 kV transmission lines don't have sufficient capacity to serve additional loads during contingencies. Hence, mitigation plan should be devised to address the near and long-term load serving needs of the area.

## **5. Mitigation Plans**

It is apparent from the above discussion that a stronger redundant source is required to solve major issues, such as low voltages and transmission line overload concerns, in the study area. It is noted that multiple proposed projects will strengthen existing sources to the study area. However, the 69 kV system in the study area is very long and the electrical source strength isn't sufficient and sustained. This means that even if the some of the sources to the study area are strengthened by the proposed projects, they are electrically too far to serve load at the other end of the transmission system during contingencies. Therefore, the existing transmission system requires improvements in the form or additional source to the load center of the study area to address the load serving needs of the area for long-term.

Mitigation of the low voltage and transmission line overload concerns in the study area will involve an introduction of new source to the load center. Construction of new transmission lines from either of the two strong sources in the vicinity of the study area was determined to be the best means to introduce a new source to the area. The two strong sources in the area are the Lake Marion (future Chub Lake) and Sheas Lake sources.

Sheas Lake is a 345/115/69 kV substation that is being constructed by NSP. This source will be connected along the Wilmarth to Blue Lake 345 kV line. The reliability of this transmission line and the Sheas Lake substation will increase with the installation of the Helena breaker station along the Sheas Lake to Blue Lake 345 kV line. The Helena breaker station provides termination points for both the CapX Booking County to Hampton 345 kV line and the Wilmarth to Blue Lake 345 kV line.



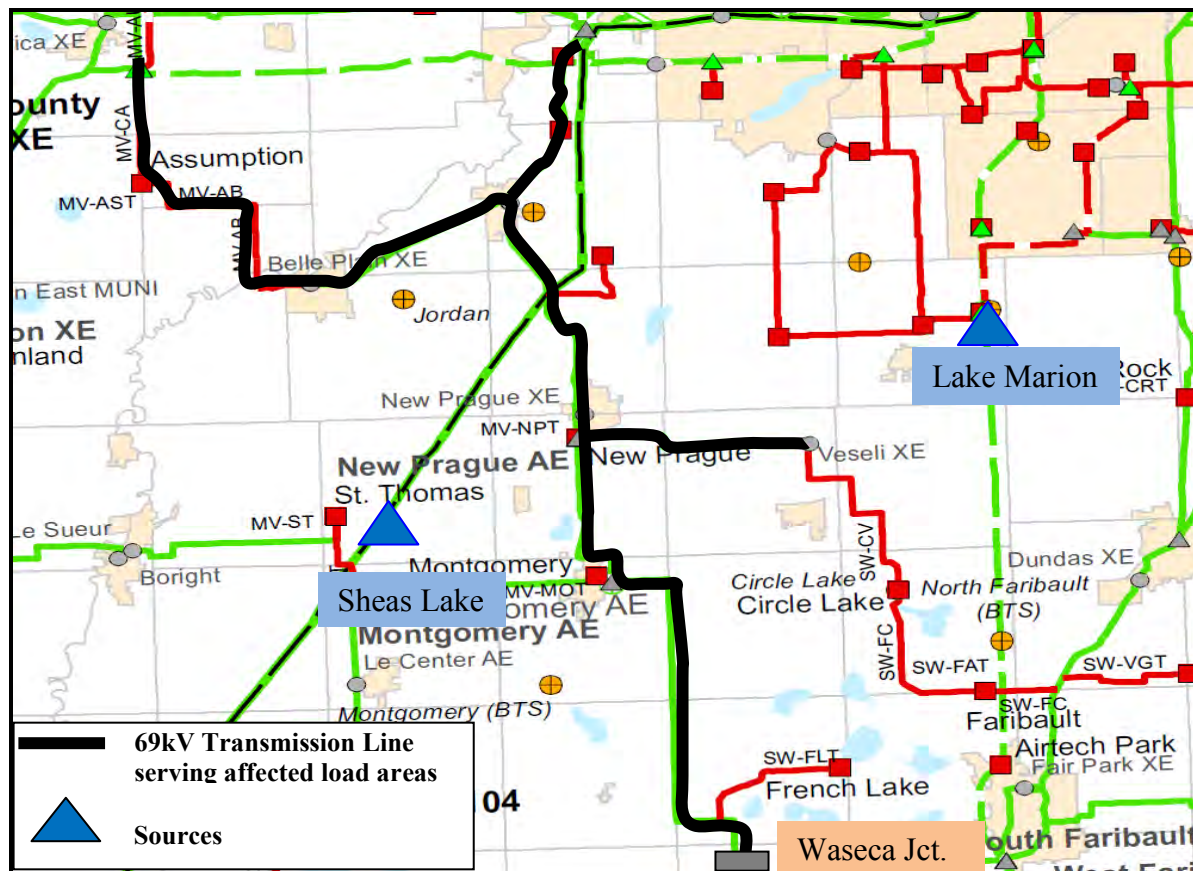

**Figure 5.1: Geographical Location of Sheas Lake and Lake Marion sources**

Lake Marion (future Chub Lake) is currently a 115/69 kV substation. As part of the Brookings County – Hampton 345 kV project, a new 345/115 kV substation will be installed next to the Lake Marion substation. This will strengthen the existing Lake Marion substation as well as other sources in the area.

The location of these sources relative to the 69 kV transmission system serving the affected load areas and the fact that these sources are the strongest sources supported by a high voltage transmission system have made them the preferred choice for sources to the study area. As discussed below, two transmission alternatives from each the two sources were devised and compared. A power flow analysis was performed using the MRO 2010 series -2016 Summer peak model with all the modeling assumptions for each alternative. The following alternatives are discussed in detail in the report:-

### 1. Using Sheas Lake as a Source:

The following two options, Option 1(a) and Option 1(b), construct new transmission lines from the Sheas Lake source to address the transmission deficiencies in the study area for a long-term.

- i. Option1 (a)-Rebuild existing lines and build a new 69 kV line from Sheas Lake to New Prague.
- ii. Option1 (b)-Build a new 69 kV line from Sheas Lake to New Prague and 115 kV line between Sheas Lake and Scott County.

## **2. Using Lake Marion (Chub Lake) as a Source (Preferred) :**

The following two options, Option 2(a) and Option 2(b), recommend construction of new transmission lines and upgrading existing transmission lines in the area. The following are the options:

- i. Option2 (a)-Build a new 115 kV line from Lake Marion to Veseli and install a 115/69 kV substation at Veseli.
- ii. Option2 (b)-Rebuild existing 69 kV line from Lake Marion Substation to New Market and build a new double circuit line between New Market and Veseli substations.(Preferred)

### **5.1 Using Sheas Lake as a Source:**

The proposed Sheas Lake substation is designed to provide connectivity to 115 kV and 69 kV voltage levels in the future. This substation connects to the CapX Brookings to Hampton 345 kV line, which makes it the strongest and most suitable source for this area. Interconnection of the Sheas Lake source with the 69 kV transmission system may cause overload problems on the 69 kV transmission system due to through flows during contingencies on the 345 kV system, such as loss of Sheas Lake to Blue Lake 345 kV line. This probable overload can be addressed with the New Prague area loads served from two different loops, which are connected by a normally open switch. The two loops are identified as the “North Loop Loads” and “South Loop Loads” follows:

- a) North Loop Load consists of all loads supported between Scott County and Carver County 69 kV transmission line via Jordan. This loop serves the Assumption , Belle Plaine, Jordan, Merriam Junction and Gifford Lake loads.
- b) South Loop Load consists of all loads south of Jordan, which includes the Sand Creek, New Prague, Veseli, French Lake and Waseca loads.

The transmission systems serving the North Loop Loads and the South Loop Loads are electrically separated by a normally open switch at Jordan along the Jordan to Sand Creek Tap 69 kV line.

The absence of any underlying 115 kV lines connected to Sheas Lake is one of the reasons for the through flow on the 69 kV lines during the Sheas Lake – Blue Lake 345 kV line outage. Any future 115 kV interconnections to Sheas Lake substation are unknown at this time. But any such projects in the future will require building a very long 115 kV transmission line to either the Scott County or Carver County 115/69 kV substations. Such a build may not be an economically viable option for the identified problems in the study area; however, it will be studied as one of the solution to address the problems in the study area in the long-term. In addition, for the loss of 115/69 kV or the 345/115 kV transformer at Sheas Lake, the system will be disconnected from the 345 kV source and will solely rely on heavily loaded 69 kV lines connecting to Wilmarth to the south. This will cause overload concerns on the 69 kV transmission system between Wilmarth and Sheas Lake, as explained below.

#### **5.1.1 Option 1(a)-Build a new 69 kV line from Sheas Lake to New Prague**

With the New Prague Area loads separated in to two load loops, the North and South Loop Loads, this option includes constructing a new 69 kV transmission line from Sheas Lake to the New Prague area to serve loads south of Jordan, the South Loop Load. This will address

the low voltage and transmission line overload concerns on the transmission system serving the South Loop Load. This option also includes rebuilding the Carver County – Belle Plaine 4/0 A 69 kV transmission line with 795 ACSR conductor. This will improve the voltage profile of the 69 kV transmission system that serves the North Loop Load and address the overload concerns on the Carver County – Belle Plaine 69 kV transmission line.

An attempt was also made to introduce a redundant 69 kV source from the east by closing the normally open switch at Veseli Tap that connects it to the West Faribault source via Circle Lake. This, however, causes transmission line overload concern on the Valley Grove to Circle Lake 69 kV transmission line. This option requires rebuilding the Valley Grove to Circle Lake 9.5 mile 1/0A conductor with 477 ACSR or larger conductor to address the overload concerns on the line when using this tie to bring the Faribault source in to assist serving the New Prague Area loads. Along with the closure of the normally open switch at Veseli, this option also requires the construction of a Valley Grove breaker station at Valley Grove Junction in order to avoid the creation of a three terminal line point at Valley Grove Junction.

Other system upgrades with this option include the replacement of the Eagle Lake Tap switches, which are limiting the conductor current-carrying capability, and the rebuild of James Town Tap – Eagle Lake Tap, 4/0A, 2.8 mile 69 kV line with 477ACSR conductor. The following summarizes the list of projects that included Option 1(a):

1. Build a new 10-mile 69kV line between Sheas Lake and New Prague Tap with 795 ACSR/ACSS conductor;
2. Rebuild 15.4-mile existing 69 kV line from Carver County to Assumption to Belle Plaine with 795 ACSR/ACSS conductor;
3. Install a new 69 kV switch termination breaker at New Prague breaker station;
4. Replace the 69 kV line switch (4S316) at Eagle Lake substation that is limiting the Eagle Lake to GRE Eagle Lake 69 kV line current carrying capability;
5. Replace the 69 kV line switch (4S317) at Eagle Lake substation limiting the Eagle Lake to James Town tap 69 kV line current-carrying capability;
6. Rebuild the 69kV line from James Town Tap to Eagle Lake Tap 2.8 mile 69 kV line with 477 ACSR conductor;
7. Construct a 3-breaker 69 kV breaker station at Valley Grove Junction;
8. Rebuild Valley Grove Junction to Faribault to Circle Lake, 9.5 mile 1/0A conductor with 477 ACSR/ACSS conductor;
9. Rebuild the New Prague Junction to New Prague Municipal , 0.4 mile 69kV line with 477 ACSR/ACSS conductor; and
10. Install a new 69 kV breaker at New Prague junction for re-terminating the line from Veseli.

### **5.1.2 Option 1(b) - Build a new 69 kV line from Sheas Lake to New Prague and 115 kV line between Scott County and Sheas Lake**

This option includes upgrading existing 69 kV transmission lines from Scott County to Jordan to 115 kV. This involves upgrading existing distribution substations, such as Gifford Lake, Merriam Junction, and Jordan, to receive 115 kV service. Along with upgrading the Scott County to Jordan 69 kV line to 115 kV, this option includes constructing a new 115 kV transmission line from Jordan to Sheas Lake to complete the 115 kV loop. A new 115/69 kV

substation at Belle Plaine is recommended to provide a loop feed to the Assumption and Belle Plaine loads at system intact and also provide a contingency support to the South Loop Load.

This option also includes constructing a new 69 kV line from Sheas Lake to the New Prague area to provide support to the South Loop Load. Similar to Option1 (a), a normally open switch is needed on the Jordan to Sand Creek Tap 69 kV line to prevent through flows that will result from the loss of Sheas Lake to Blue Lake 345 kV line under high wind output conditions. Also, similar to Option1 (a), this option requires rebuilding the Valley Grove to Circle Lake 69 kV line with 477 ACSR/ACSS conductor and closing in the Veseli normally open switch to provide a more redundant source to the South Loop Load from the east.

The following summarizes the projects included in Option1 (b):

1. Upgrade the Scott County to Jordan 69 kV line to 115 kV operations;
2. Upgrade Gifford Lake, Merriam Junction, and Jordan distribution substations to receive 115 kV service;
3. Install a new 115 kV Breaker at Scott County for line termination;
4. Build a new 10- mile 69 kV line between Sheas Lake and New Prague Tap with 795 ACSR/ACSS conductor;
5. Install a new 69 kV switch termination breaker at New Prague breaker station;
6. Rebuild the Jordan to Belle Plaine 69 kV 8 mile line with 795 ACSS conductor;
7. Establish a new 115/69 kV, 80 MVA substation at Belle Plaine;
8. Build a new 115 kV, 10 mile, line from Belle Plaine to Sheas Lake with 795 ACSR/ACSS conductor;
9. Construct a 3-breaker 69 kV breaker station at Valley Grove;
10. Rebuild Valley Grove Junction to Faribault to Circle Lake (9.5 mile) 69 kV, 1/0A conductor with 477 ACSR/ACSS conductor;
11. Rebuild the New Prague junction to New Prague Municipal, 0.4 mile, 69kV line with 477ACSR/ACSS conductor;
12. Install a new 69 kV breaker at New Prague Junction for re-terminating the line from Veseli;
13. Replace the 69kV line switch (4S316) at Eagle lake substation that is limiting the Eagle Lake to GRE Eagle Lake 69 kV line current Carrying capability;
14. Replace the 69kV line switch (4S317) at Eagle Lake substation limiting the Eagle Lake to James Town Tap 69 kV line current carrying capability; and
15. Rebuild the 69kV line from James Town Tap to Eagle Lake Tap 2.8 mile 69 kV line with 477 ACSR conductor.

## **5.2 Using Lake Marion/Chub Lake as a Source:**

The Lake Marion (Chub Lake) source is the strongest and closest source to the east of the New Prague Area. The future CapX Brookings to Hampton 345 kV line will connect at Lake Marion with a new Chub Lake 345/115 kV substation, which makes Lake Marion suitable for sourcing new transmission lines to serve loads in the study area for a long term. In addition to a strong 115 kV network, the Lake Marion source is also connected to the Black Dog generating station through a 115 kV transmission line via Burnsville. The Lake Marion to Burnsville 115 kV line section is planned to be re-conducted with bundled 795 ACSS conductor, which will address the line overload concerns as a result of high flows when the

CapX 345 kV line is energized. The Black Dog generating station provides additional redundancy making Lake Marion a strong and reliable source for load serving in the area.

The study area can be supported from the Lake Marion source with Option 2(a), which recommends constructing a new 115 kV line from the Lake Marion – Faribault Energy Park 115 kV line to NSP’s Veseli substation and installing a 115/69 kV transformer at Veseli, or with Option 2(b), which recommends rebuilding existing 69 kV transmission lines to 115 kV standard and constructing a new double circuit 69 kV line from the New Market area to Veseli substation. These two options are discussed in detail below.

### **5.2.1 Option 2(a)-Build a new 115 kV line from Lake Marion to Veseli Substation**

This option includes constructing a new 115 kV line from the Lake Marion Substation to Veseli and installing a 115/69 kV transformer at Veseli for voltage transformation. The 115 kV line ties the Lake Marion source to the New Prague area via Veseli. The following summarizes the projects included in Option 2(a):

1. Construct a new 13.5-mile 115 kV line from Lake Marion to Veseli;
2. Install 115 kV breakers at Lake Marion for new line termination;
3. Construct a 115/69 kV, 112 MVA substation at Veseli; and
4. Build a new 69 kV, 4-breaker straight bus breaker station at Veseli.

Currently, there is a 2.5 mile double circuit 69 kV line that runs between the Lake Marion substation and Lake Marion Tap. With this option, one of the double circuit 69 kV lines between Lake Marion and Lake Marion Tap will be rebuilt with 795 ACSS conductor, operated at 115 kV, and used as part of the 13.5 mile 115 kV line that is needed under this option. This leaves only one 2.5 mile 69 kV line out of the Lake Marion substation to serve loads in the Lake Marion to Glendale 69 kV system. Contingency analysis showed that the loss of this single circuit 2.5 mile 69 kV line between Lake Marion and Lake Marion Tap overloads the 69 kV line between Prior Lake Junction to Credit River Junction that consists of 4/0A conductor. To avoid the line overload during contingency, this portion of the line, from Prior Lake Junction to Credit River Junction, 3.51 mile, 69 kV line, will be rebuilt with 795 ACSS/ACSR conductor as part of Option 2(a).

The loss of the 69 kV transmission line from Lake Marion Tap to Elko will also cause an overload concern on the Credit River Junction to Cleary Lake to NSP Credit River Tap 69 kV line, as shown in Figure 5.3 below. This scenario is discussed in detail in Option 2(b). This particular line overload concern was identified in past studies and a project to rebuild the overloaded sections of the transmission line with a high capacity conductor was scheduled. Further analysis of the 69 kV system between Lake Marion and Glendale showed that the loss of the Credit River Junction to Cleary Lake 69 kV line causes low voltage problems in the Cleary Lake and Credit River areas as illustrated in Figure 5.5 below. As a solution to address the low voltage problem, two alternatives were considered:

1. Install a 10 MVar capacitor bank at Cleary Lake
2. Double circuit the Credit River to Cleary Lake 0.95 mile line and serve the Cleary Lake load from Lake Marion at system intact

The option to install a 10 MVAR capacitor bank was not preferred due to the cost, longevity, and improvements it provides as discussed in the following.

1. Installation of a 10 MVAR capacitor bank requires expanding the 69 kV bus work at Cleary Lake, a 69 kV breaker for disconnect and installing a capacitor bank. This would cost approximately \$300,000 excluding the cost to expand the 69 kV bus at Cleary Lake.
2. The incremental load serving capability of the 10 MVAR capacitor bank is significantly half that of the alternative.
3. With the installation of the capacitor bank, the Lake Marion to Lake Marion Tap, also known as the DA-AN, overloads during contingency on the Credit River Junction to Cleary Lake Tap 69 kV line and will need to be rebuilt with 795 ACSS conductor.

In contrast to the capacitor bank alternative, modifying the line rebuild Credit River Junction to Cleary Lake Tap line rebuild project that is required. This modification will be completed in such a way that the existing Credit River Junction to Cleary Lake 69 kV line will be rebuilt in a double circuit configuration and the Cleary Lake substation will normally be served from the Lake Marion substation. This alternative is preferred to the capacitor bank installation alternative for the following reasons:

1. The incremental cost of double circuiting the 0.95 mile 69 kV line is about \$175,000;
2. It provides an incremental load serving capability of 34 MW as compared to 17 MW for the capacitor bank alternative;
3. The Lake Marion to Lake Marion Tap (DA-AN) 69 kV line rebuild is not required as serving the Cleary Lake Load using one of the double circuit lines on the DA-AN line take load off of the second DA-AN line and provides sufficient capacity to serve loads in the system without overload issues;
4. Provides longer life for the Glendale transformer to server loads in the system; and
5. Provides better load serving reliability as Cleary Lake is served from a separate circuit

Figures 5.2a and 5.2b show the configuration of the 69 kV transmission system with Option 2(a) build out.

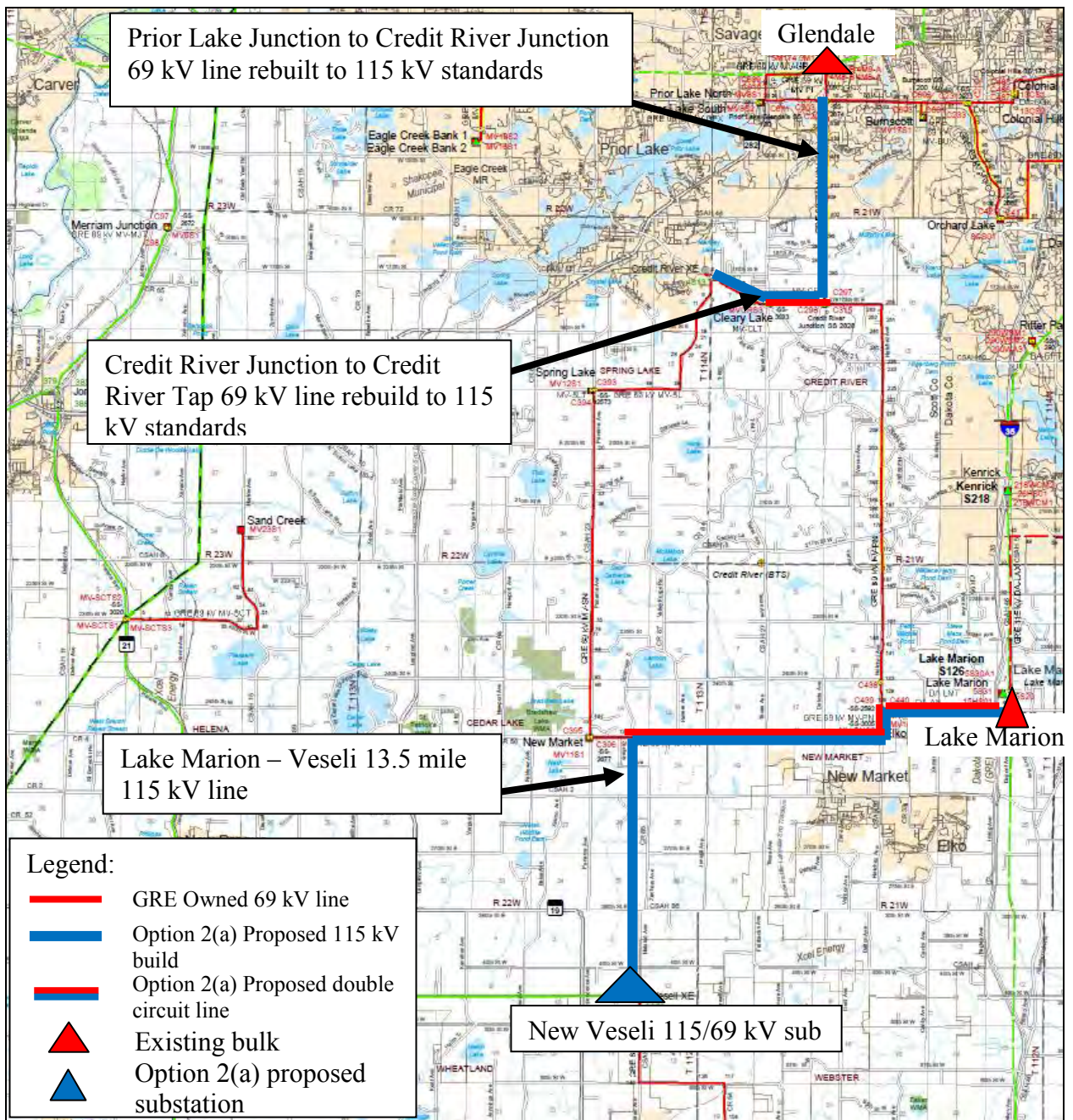
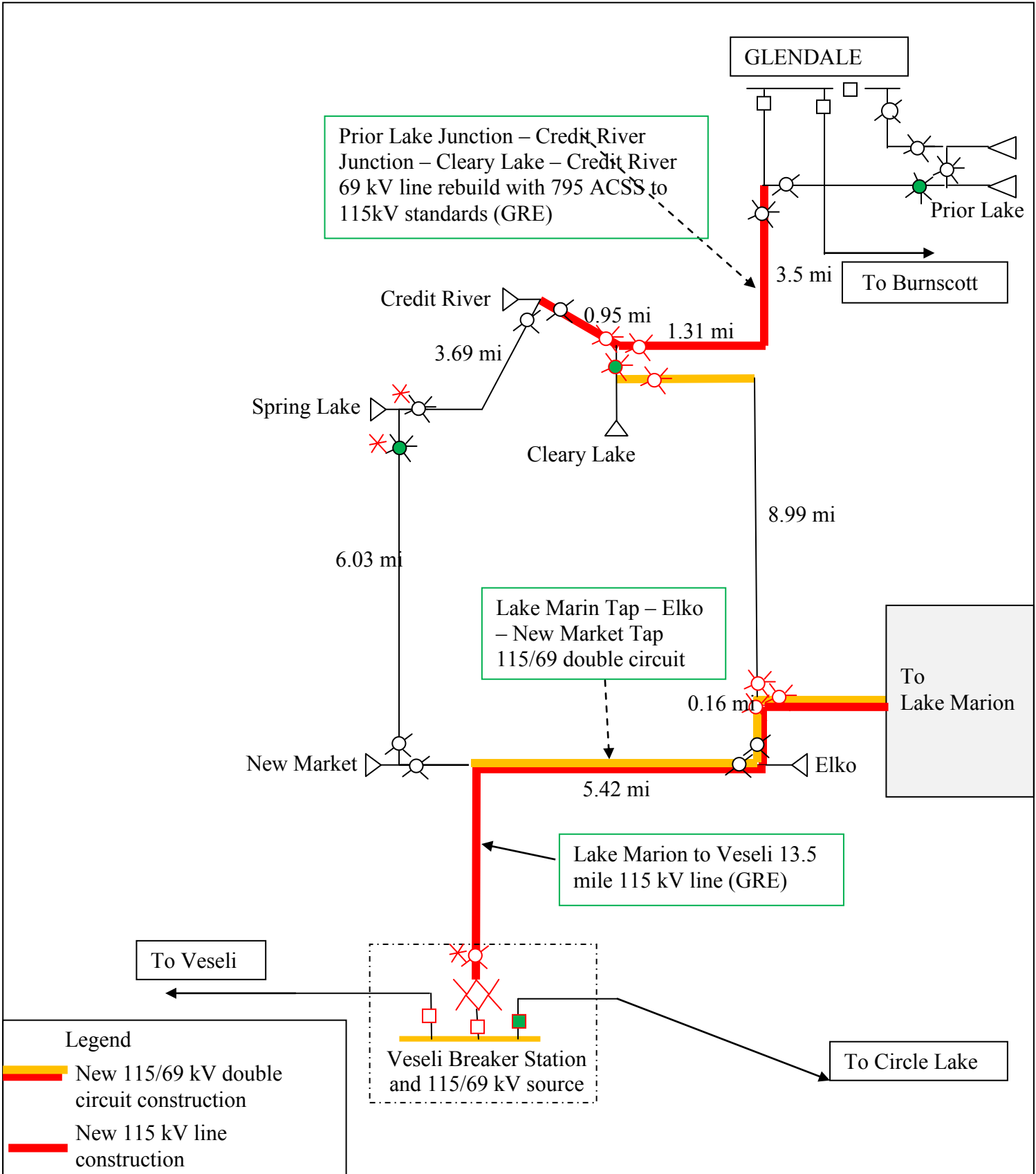

Figure 5.2a: Option 2(a) build out – Geographical Map



**Figure 5.2b: Option 2(a) build-out – one-line.**



### **5.2.2 Option 2(b)-Rebuild existing 69 kV line from Lake Marion Substation to New Market and build a new double circuit line between New Market and Veseli.**

This option includes rebuilding existing 69 kV transmission lines from Lake Marion to Elko to New Market 69 kV line and constructing a new double circuit 69 kV line from MVEC's New Market substation to NSP's Veseli substation. This option, in addition to the Lake Marion source, introduces the Glendale 115/69 kV source to assist serving the study area loads. The Lake Marion to Elko to New Market 69 kV line rebuild will be done with 795 ACSS conductor and be constructed to 115 kV standards for future 115 kV operations. Similarly, the new double circuit 69 kV line construction will be constructed with 795 ACSS conductor, and it will be constructed to 115 kV standards, but will be operated at 69 kV until load growth in the area requires 115 kV operation.

Past studies of the Glendale to Lake Marion 69 kV transmission system indicated near-term transmission line overload concerns on 4/0A conductor of the Credit River Junction to Cleary Lake to Credit River Tap 69 kV line. GRE had scheduled to rebuild these line in the 2013-14 timeframe to address the overload concerns. As this line rebuild is part of the preferred option, it will be done as part of the preferred transmission project for the areas and is proposed to be a rebuild to 115 kV standards as a need for this operation is forecast for approximately 2030.

As the recommended facilities in Option 2(b) are tied to the 69 kV system between Glendale and Lake Marion, it is worth summarizing the transmission concerns in this system as they need to be addressed for Option 2(b) to work. The following one-line diagrams illustrate the near-term transmission system concerns in the Lake Marion to Glendale 69 kV transmission system based on new load forecast of the area as documented in Section 3.2 and in Appendix C of this study. The critical contingencies for the Glendale to Lake Marion 69 kV system are:

- Lake Marion to Lake Marion Tap 2.48-mile 69 kV line outage;
- Lake Marion Tap to Elko 0.16-mile 69 kV line outage; and
- Credit River Junction to Cleary Lake 0.95- mile 69 kV line outage.

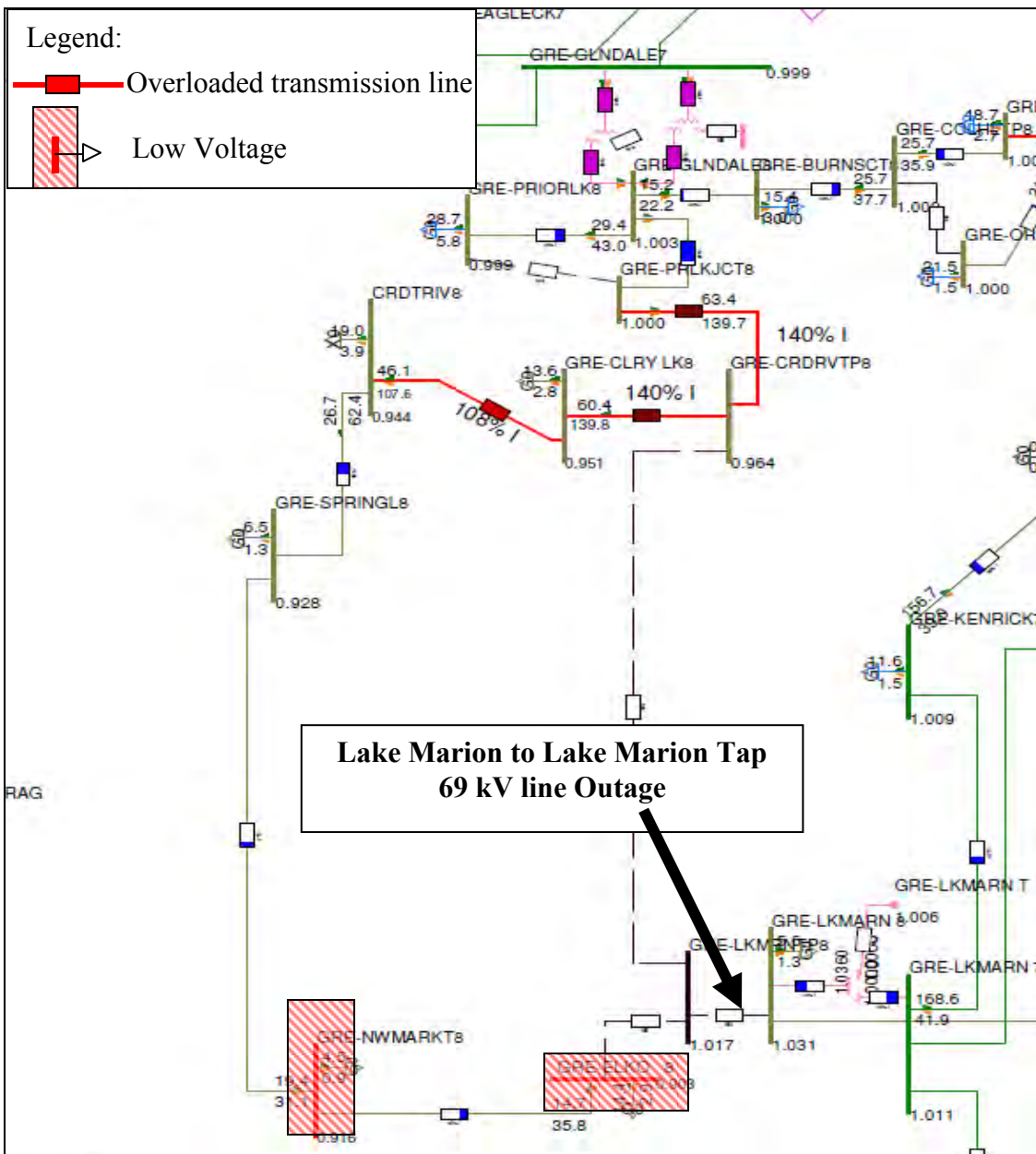

**Figure 5.3: Lake Marion to Lake Marion Tap 69 kV line outage**

The above one-line diagram shows that the Prior Lake Junction to Credit River Tap 69 kV line and the Credit River Tap to Cleary Lake Tap 69 kV line are loaded to 140% for an outage on the double circuit portion of the 69 kV line between Lake Marion and Lake Marion Tap (Figure 5.3). The Lake Marion to Lake Marion Tap 69 kV line outage also loads the Cleary Lake to Credit River Tap 69 kV line to 108% and cause low voltage concerns at Elko (0.90 pu) and New Market (0.92 pu). The line loadings violate the 100% line loading criteria. Therefore, they need to be upgraded, for example rebuilt with 795 ACSS conductor, to bring the line loading within criteria.

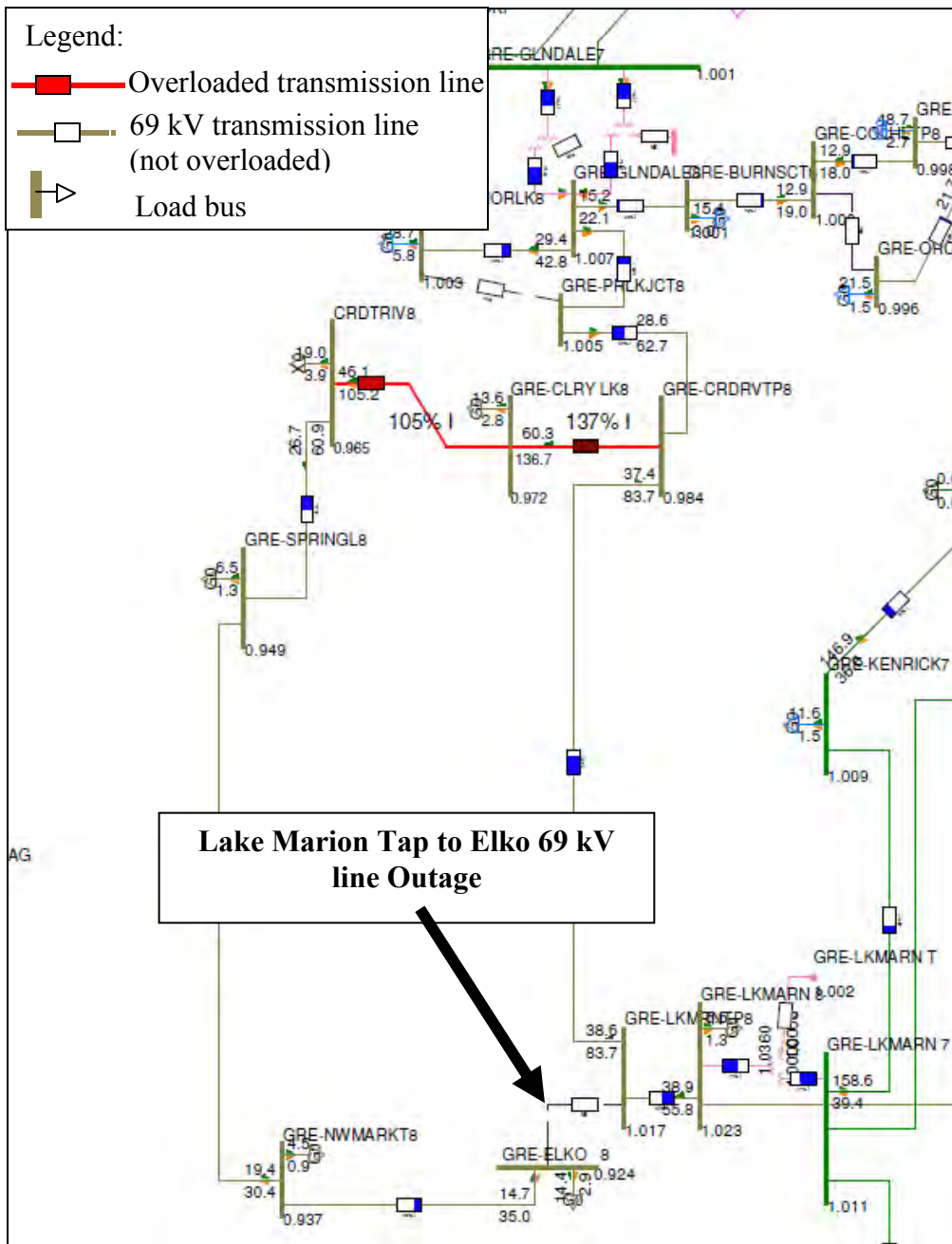

**Figure 5.4 Lake Marion Tap to Elko 69 kV line outage**

The loss of the Lake Marion Tap to Elko Tap 69 kV line causes overload concerns on the Credit River Tap to Cleary Lake 69 kV line (137%) and Cleary Lake to Credit River 69 kV line (105%) as shown in Figure 5.4. A rebuild of the overloaded lines with larger conductor addresses the line overload concern.

As Figure 5.5 illustrates, the loss of the Credit River Tap to Cleary Lake 69 kV line causes low voltage problems at Cleary Lake (0.90 pu) and Credit River (0.90 pu), and overloads the Lake Marion to Elko 69 kV line (140%) and the Elko to New Market 69 kV line (108%).

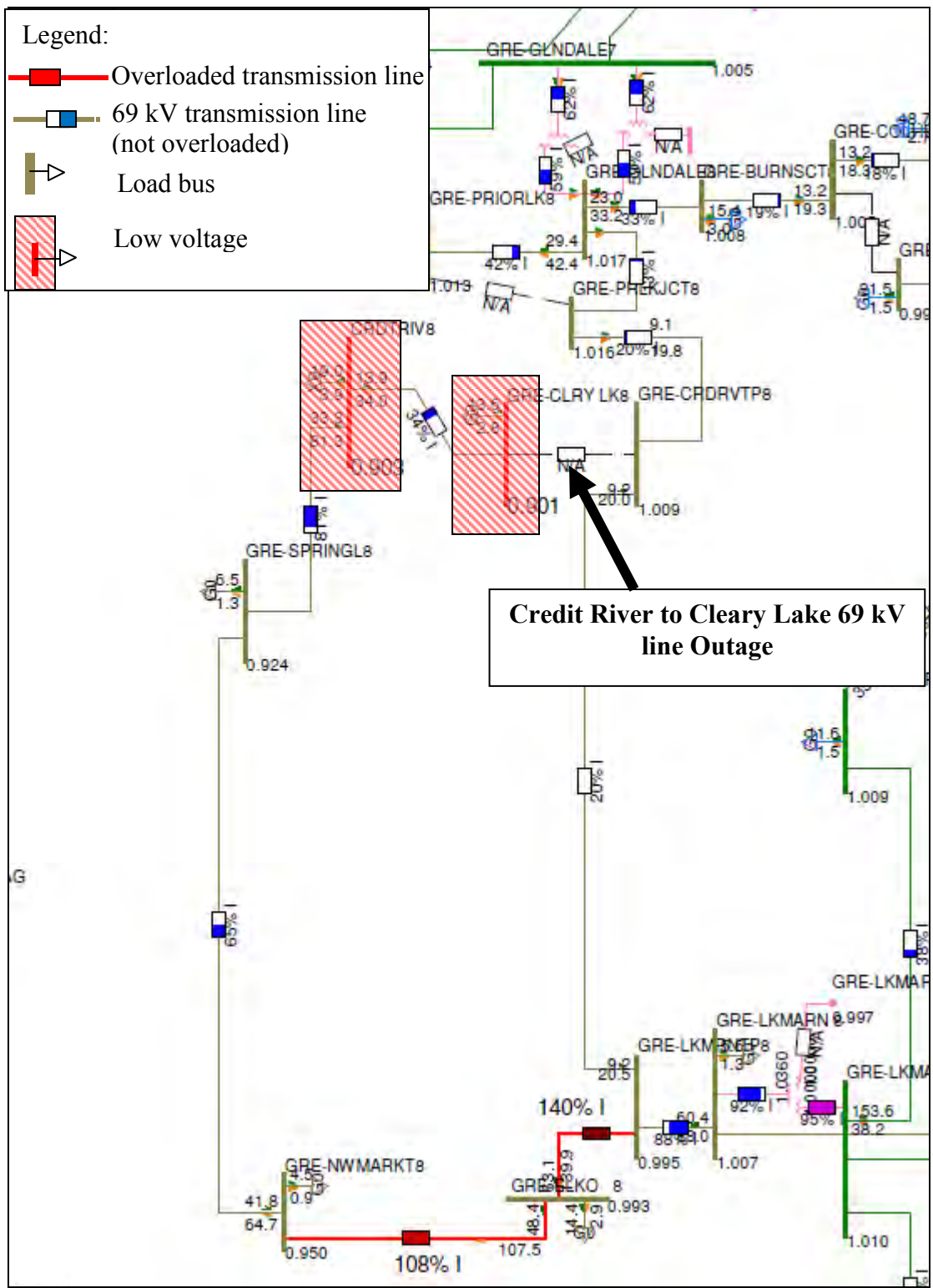

**Figure 5.5 Credit River Tap to Cleary Lake 69 kV line outage**

From the above discussion, the Glendale to Lake Marion 69 kV system requires improvement in the near-term to bring the line loading and low voltage issues within criteria. As these lines are old, the overloaded sections in these are will be rebuilt with a high capacity conductor.

This study, with Option 2(b), also showed that the Credit River Junction to Cleary Lake to Credit River Tap 69 kV line overloads during contingencies, such as loss of the Lake Marion 115/69 kV transformer or Lake Marion to Lake Marion Tap 69 kV line. Similarly, the loss of the Lake Marion 115/69 kV transformer or Lake Marion to Lake Marion Tap 69 kV line overloads the Prior Lake Junction to Credit River Tap 69 kV line in the near-term. This is due to the Glendale 115/69 kV substation serving all loads in the Glendale to Lake Marion 69 kV system in addition to providing support to the study area load via the new line, New Market to Veseli 69 kV line. In order to address these overload concerns, the overloaded sections of the transmission system will be rebuilt with 477 ACSS, or larger, conductor as part of this option.

Rebuilding the Credit River Junction to Cleary Lake 69 kV line will only address the line overload concern but not the low voltage concerns at Cleary Lake and Credit River areas for the loss of the Credit River Junction to Cleary Lake 69 kV line. To address the low voltage concern, as discussed in Option 2(a), the Credit River to Cleary Lake 69 kV line rebuild will be done in a double circuit configuration, i.e., a new 0.95 mile 69 kV line that is capable for future 115 kV operation will be constructed between Credit River Junction and Cleary Lake Tap and this circuit will be underbuilt with the existing 69 kV line between Credit River Junction and Cleary Lake Tap. The Credit River Junction switch will be retired and the Cleary Lake substation will be served from the Lake Marion substation at system intact.

The following summarizes list of projects that should be accomplished as part of Option 2(b) and the one-line diagram shows final build out of Option 2(b).

1. Rebuild Lake Marion to Elko to New Market, 8.2 miles, 4/0A, 69 kV line with 795ACSS conductor;
2. Build about 6 miles of double circuit 69 kV line from New Market Tap to NSP's Veseli substation. This line will be constructed to 115 kV standards using 795 ACSS conductor;
3. Build a new 69 kV, 4-breaker straight bus breaker station at Veseli Substation;
4. Install a 115 kV three way load break switch at New Market Tap;
5. Double Circuit the Credit River Junction to Cleary 0.95 mile 69 kV line with 477ACSR, or larger, conductor;
6. Rebuild Credit River Tap to Cleary Lake 1.3 mile 69 kV line with 477 ACSS, or larger, conductor; and
7. Rebuild Prior Lake Junction to Credit River junction 4 miles 69 kV line with 477ACSS, or larger, conductor

All the line rebuilds and new line constructions will be designed to 115 kV standards for future 115 kV operations. When load growth in the area requires system improvement, the Lake Marion to Elko to New Market to Veseli circuit will be operated at 115 kV and new 115/69 kV transformer will be installed at Veseli for voltage transformation. The need for the Lake Marion to Elko to New Market to Veseli circuit operation at 115 kV and the installation of the Veseli 115/69 kV substation is projected to be in the 2020/2022 timeframe.

Note that the Lake Marion to Elko to New Market to Veseli line that will be a radial 115 kV line when operated at 115 kV. For a stronger and reliably service to the study area and the 69 kV system between Glendale and Lake Marion, this radial line should be looped to the Glendale 115 kV bus. Therefore, overloaded transmission lines along the New Market to Spring Lake to Credit River to Cleary Lake to Glendale circuit will be rebuilt to 115 kV

standard for future 115 kV operation. In line with this proposed plan, overloaded transmission lines, such as the Prior Lake to Credit River Junction 69 kV line, Credit River Junction to Cleary Lake 69 kV line and Cleary Lake to Credit River 69 kV line will be rebuilt to 115 kV standard for continued 69 kV operation. According to the current load projections, the need for 115 kV operation is expected to be in the years between 2027 and 2030. The New Market to Spring Lake 69 kV line and Spring Lake to Cleary Lake 69 kV lines have sufficient capacity to serve expected loads in the area. These lines will be rebuilt to 115 kV standards with 795 ACSS conductor when the lines begin experiencing overload concerns. The following geographical map, Figure 5.6a, and one-line diagram, Figure 5.6b, illustrate the transmission addition as recommended by Option 2(b).

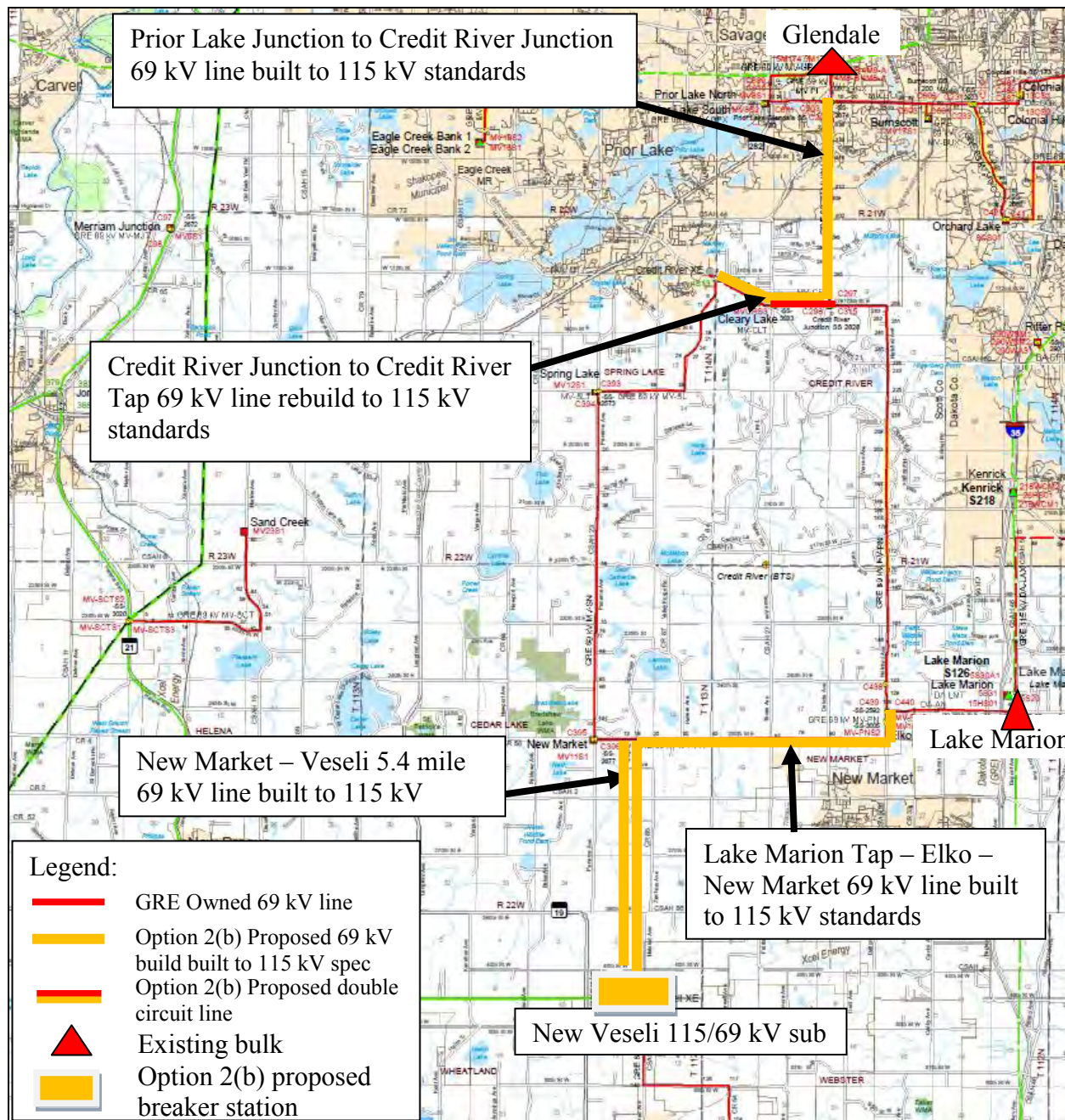
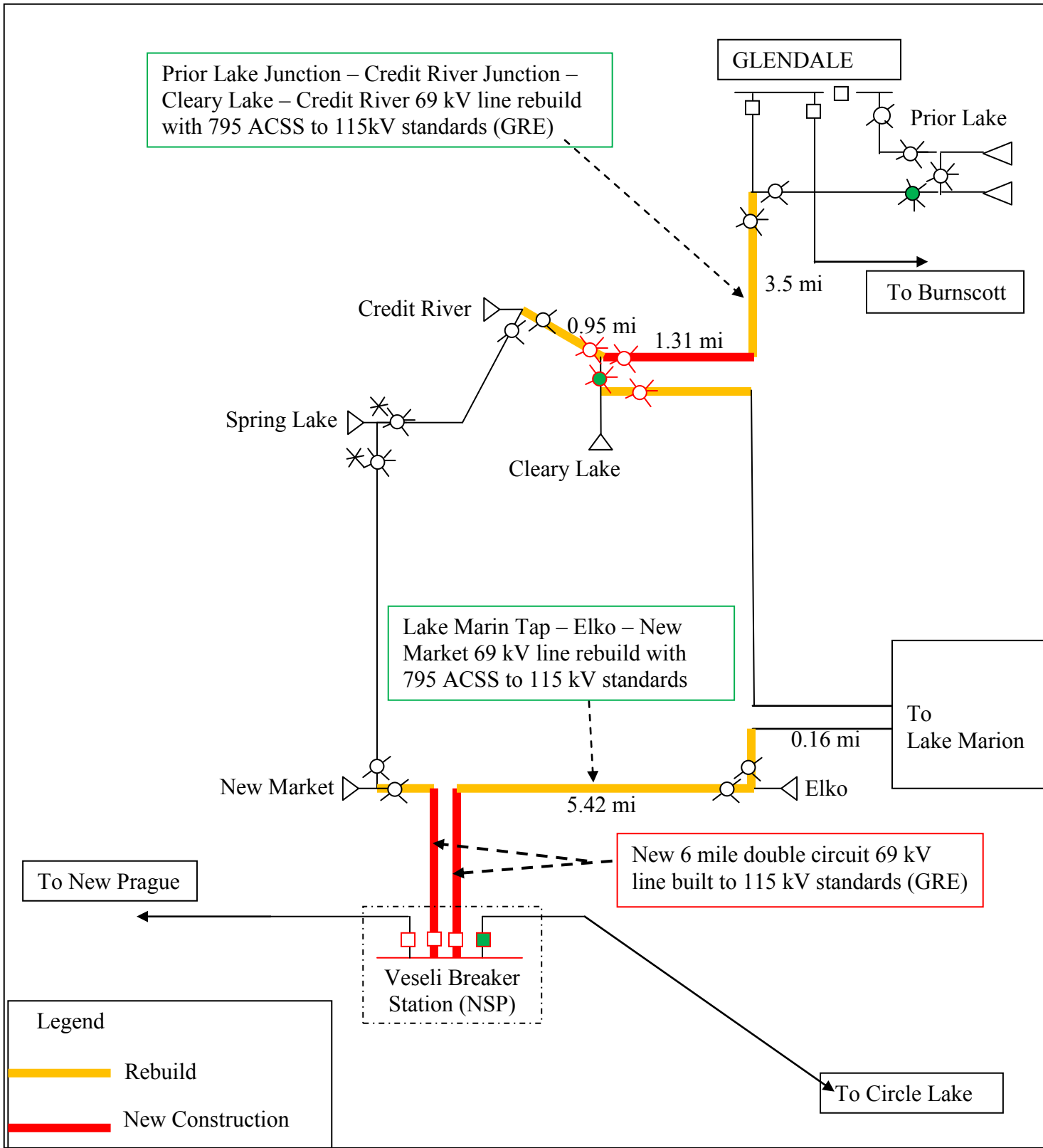

Figure 5.6a: Option 2(b) build out – Geographical Map



**Figure 5.6b: One-line diagram of Option 2(b)**

Note that all the four options analyzed in this study recommend establishing a breaker station at the location close to NSP's Jordan distribution substation. Currently, three 69 kV lines, each from Carver County, Scott County and New Prague, meet near to Jordan substation and create a three terminal line point. Each of these three lines will be re-terminated at the breaker station and, thereby; the three terminal point is eliminated. The breaker station will significantly improve the reliability of the 69 kV transmission system in the area and provide more operational flexibility.

Option 2(b) recommends closing the existing normally open switch at Spring Lake and opening the Lake Marion to Credit River Junction 69 kV line in order to avoid the creation of three terminal line points at Credit River Junction. Three terminal lines, in general, cause operational problems and put more loads at risk during contingency.

## **6. ACCC/Contingency Analysis Results:**

The load serving performance of each of the alternatives, Option 2(a) and Option 2(b), which are sourced from the Lake Marion substation were compared using an out-year model, 2016 summer peak. The study models were updated to include the recommended transmission additions for each option and contingency analysis was performed. Note that Option 1(a) and Option 1(b) was found to have an initial investment that is significantly higher than Option 2(a) and Option 2(b) as shown in economic analysis section of this study. Therefore, further analyses on the options are carried for only Options 2(a) and 2(b).

### **6.1 Load Serving Performance of Option 2(a)**

Contingency analysis showed that the transmission line overload and low voltage concerns in the study area are addressed for a long-term with the installation of facilities as recommended under option 2(a). Neither low voltage nor branch overload concerns were identified in the study area with Option 2(a).

#### **6.1.1 Incremental Load Analysis**

Incremental load analysis was performed to determine the longevity of Option 2(a). Affected area loads in the 69 kV system bounded by the Carver County, Scott County, Faribault and Owatanna as well as loads served from the Glendale to Lake Marion 69 kV system were included in the incremental load analysis. Appendix B has a table with list of loads that are used in the incremental load analysis.

The incremental load analysis showed that the existing transmission system with Option 2(a) can serve additional 40 MW load beyond the 2016 load level in the study area. The initial 2016 load level used in the analysis was 173 MW, and this incremental load amounts about 23% of the projected 2016 load level. The PV analysis showed that the Gifford Lake area will start to experience low voltage concerns after 40MW incremental load for the Scott County to Gifford Lake 69 kV line outage. This contingency also causes overload concern on the Carver County to Assumption 69 kV line after 48 MW incremental loads. Appendix D contains the PV curves showing the incremental load serving capability of Option 2(a).



## **6.2 Load Serving Performance of Option 2(b)**

Contingency analysis showed that this option addresses the transmission line overload and low voltage concerns in the study area for a long-term. No transmission line overload or low voltage concerns were identified in the study area after the addition the recommended facilities in Option 2(b).

### **6.2.1 Incremental Load Analysis**

Incremental load analysis was performed with Option 2(b) to determine the amount of additional load that can be served in the study area before experiencing low voltage or transmission line overload concerns. Loads mostly in the affected load area were chosen for this analysis. The full list of loads used for the incremental load analysis along with the initial load level is included in Appendix B. The projected summer 2016 load level in the study area, which amounts to 173 MW, was the initial load level.

The incremental load analysis showed that the transmission system with the addition of the recommended facilities under Option 2(b) can serve additional 15 MW of load in the affected areas before the 115/69 kV source at Veseli is required. With the installation of the 115/69 kV substation at Veseli and operation of Lake Marion to Elko to New Market to Veseli line at 115 kV, Option 2(b) is capable of serving 37 MW of increment load in the affected areas. This amounts about 25% of the total 2016 load level in the affected area. Gifford Lake experiences low voltage concerns in after 37 MW of incremental load.

The incremental load analysis show that the Carver County to Assumption 69 kV line overloads after 43 MW incremental load on top of the 2016 load level in option 2(b). The Cleary Lake area will start to experience low voltage concerns after 77 MW incremental load as shown in the PV curves in Appendix E.

## 7. Economic Analysis

Indicative cost estimates for the various options are provided below. Based on these indicative cost estimates and present worth analysis Option 2(b) is shown to be the least cost based on the initial facilities required for this alternative. Indicative estimates are a high level cost estimates that are used to compare alternatives.

### i. Option 1(a) - Build a new 69 kV line from Sheas Lake.

In-service Date	Projects	2012 UNIT COST
2016	Build a new 69 kV line from Sheas Lake to New Prague to 477A or 795A (10 miles)	\$4,200,000.00
2016	Install a new 69kV breaker at Sheas lake	\$650,000.00
2016	Install two new 69kV breakers at New Prague Junction to terminate line from Sheas Lake and Veseli	\$740,000.00
2016	Rebuild the 69 kV from New Prague junction to New Prague Municipal to 477A (0.4 mile)	\$115,200.00
2016	Rebuild a the Carver County - Assumption - Belle Plaine 69kV line to 795 A	\$5,359,200.00
2016	Install a new 3-breaker straight bus breaker station at Valley grove junction	\$1,400,000.00
2016	Rebuild the Faribault to Valley Grove junction 69kV line to 477 A (2.7 miles )	\$777,600.00
2016	Rebuild the Circle Lake to Faribault 69 kV line to 477A (6.9 miles)	\$1,987,200.00
2016	Rebuild the 69 kV from Jamestown tap to Eagle lake tap to 477A (2.8 miles)	\$806,400.00
2016	Replace the 69kV line switch (4S316) at Eagle Lake substation limiting the Eagle lake to GRE Eagle Lake	\$300,000.00
2016	Install a new 69 kV Breaker Station at Jordan	\$1,134,000.00
2016	New XFMR and bus work 115/69kV transformer at Sheas Lake	\$3,900,000.00
<b>Total</b>		<b>\$21,369,600.00</b>

**Total \$ 21,370,600**

**ii. Option 1(b) - Build a new 69 kV line from Sheas Lake and 115 kV line between Scott County and Sheas Lake.**

<b>In-service Date</b>	<b>115 kV line from Scott County to Sheas Lake</b>	<b>2012 UNIT COST</b>
2016	Install a new 115kV Breaker at Scott County	\$800,000.00
2016	Upgrade Jordan, Gifford Lake and Merriam junction substations to 115 kV operations.	\$1,350,000.00
2016	Rebuild line Jordan - Belle Plaine 8 miles line with 795A	\$2,784,000.00
2016	Install two new 69kV breakers at New Prague Junction to terminate line from Sheas Lake and Veseli	\$740,000.00
2016	Build a new 115kV line from Belle Plaine to Sheas Lake to 795 A (10 miles)	\$4,200,000.00
2016	Bell Plain three 115kV breakers and one 69kV breaker for new 80 MVA substation	\$5,300,000.00
2016	Install new 115/69kV at Belle Plaine (80MVA)	\$3,934,454.00
2016	Build a new 69 kV line from Sheas Lake to New Prague to 477A (10 miles)	\$4,200,000.00
2016	Install a new 69kV breaker at Sheas lake	\$650,000.00
2016	Rebuild the Faribault to Valley Grove junction 69kV line to 477 A (2.7 miles )	\$777,600.00
2016	Rebuild the Circle Lake to Faribault 69 kV line to 477A (6.9 miles)	\$1,987,200.00
2016	Rebuild the 69 kV from Jamestown tap to Eagle lake tap to 477A (2.8 miles)	\$806,400.00
2016	Replace the 69kV line switch (4S316) at Eagle lake substation limiting the Eagle lake to GRE Eagle Lake	\$300,000.00
2016	New XFMR and bus work 115/69kV transformer at Sheas Lake	\$3,900,000.00
<b>Total</b>		<b>\$31,729,654.00</b>

**Total \$ 31,730,000**

**iii. Option 2(a) - Build a new 115 kV line from Lake Marion Substation to Veseli.**

<b>In-service Date</b>	<b>Projects</b>	<b>2012 UNIT COST</b>
2016	Install new 115 kV line termination breakers at Lake Marion/Chub Lake	\$790,000.00
2016	Rebuild Lake Marion to Lake Marion Tap (DA-AN) 2.1-mile 69 kV line	\$1,027,800.00
2016	Build new line from Lake Marion Tap substation to Veseli to 11- mile of 795 ACSR conductor	\$5,959,800.00
2016	New 115/69kV 112MVA TR substation at Veseli and new 115kV line terminations	\$4,200,000.00
2016	Breakers at Veseli for terminating lines to New Prague and Faribault	\$906,750.00
2016	Install a new 115 kV three way load break switch at Lake Marion Tap	\$175,000.00
2016	Rebuild Prior Lake - Credit River Junction 3.51 mile 69 kV line	\$1,221,480.00
2016	Install a new 69 kV breaker station at Jordan	\$1,134,000.00
<b>Total Initial ( 2016) Investment</b>		<b>\$15,414,830.00</b>
2022	Install a 3-way switch near New Market on the New Market - Veseli line for new line termination from Veseli	\$175,000.00
2022	New 69 kV breaker for the future New Market - Veseli 69 kV line	\$567,000.00
2022	String the second circuit on New Market - Veseli 69 kV line	\$302,250.00
<b>Total</b>		<b>\$16,459,080.00</b>

**Total \$ 16,459,000**

**iv. Option 2(b) - Rebuild 69 kV line from Lake Marion Substation to New Market and Build a new double ckt line between New Market and Veseli.(Preferred)**

<b>Inservice Date</b>	<b>Projects</b>	<b>2012 UNIT COST</b>
2016	Rebuild Prior Lake - Credit River Junction 3.51 mile 69 kV line	\$1,221,480.00
2016	Rebuild New Market tap -Elko-Lake Marion 5.6 miles 69kV line 795A	\$1,948,800.00
2016	Build a new 5.4 mile double circuit 69 kV line built to 115kV spec	\$3,402,000.00
2016	Install breaker station at Veseli (4-breaker straight bus)	\$1,209,000.00
2016	Install breaker station at Jordan (3-breaker station)	\$1,134,000.00
<b>Total Initial ( 2016) Investment</b>		<b>\$8,915,280.00</b>
2022	Install breakers at Chub Lake	\$790,000.00
2022	New 115/69kV 112MVA TR substation at Veseli and new 115kV line terminations	\$3,822,750.00
2022	Elko distribution substation upgrade to 115 kV	\$490,000.00
2022	Rebuild Lake Marion to Lake Marion Tap (DA-AN) 2.1-mile 69 kV line	\$1,027,800.00
<b>Total</b>		<b>\$15,045,830.00</b>

**Total \$ 15,046,000**

## 8. Present Worth Analysis

Present worth analysis was performed to compare between the options and determine the best value option based on how these options perform over time. Options 1(a) and 1(b) were omitted from the present worth analysis as the initial investments of both options were found being significantly higher than the initial investments of Option 2(a) or 2(b). Option 2(b) was chosen as a benchmark for loss saving calculation. The following is the summary of the present worth analysis. The present worth spreadsheet can be found in Appendix F.

Options	Cumulative Present Worth	Cumulative Investment	PW with Loss Saving
Option 2(b)	\$27,907,000	\$19,658,000	Benchmark
Option 2(a)	\$32,879,000	\$20,438,000	\$32,327,000

The long-term transmission configurations of the two options are closely similar and so is the cumulative investment. Option 2b, however, has a lower cumulative present worth value by nearly \$4.4 million. While the long-term transmission configuration of the two options are very similar and the incremental load serving capability of the two options is also very similar with Option 2(a) having an additional 3MW load serving capability, Option 2(b) has the least initial investment, cumulative present worth and is the best value option to address the transmission needs of the area for a long-term.

As discussed in incremental load serving capability section of Option 2(b), section 6.2.1, the transmission system will serve about 15 MW incremental load when part of the recommended facilities in Option 2(b) are in-service. The following are the first phase of projects that are recommended under Option 2(b). These are expected to be in-service in the 2016 timeframe.

1. Rebuild Lake Marion to Elko to New Market, 5.6 miles, 4/0A, 69 kV line with 795ACSS conductor;
2. Build a about 5.4-mile of double circuit 69 kV line from New Market Tap to NSP's Veseli substation. This line will be constructed to 115 kV standards using 795 ACSS conductor;
3. Build a new 69 kV, 4-breaker straight bus breaker station at Veseli substation;
4. Construct a 0.95 mile 115 kV line operated at 69 kV between Credit River Junction and Cleary Lake Tap, and under build the existing Credit River Junction to Cleary Lake Tap 69 kV line;
5. Rebuild Credit River Tap to Cleary 1.3-mile 69 kV line with 795 ACSS conductor;
6. Rebuild Prior Lake Junction to Credit River Junction 3.5-mile 69 kV line with 795 ACSS conductor; and
7. Configure the normally open at Cleary Lake so that Cleary Lake is served from Lake Marion at system intact and from Glendale during the Lake Marion to Cleary Lake Tap 69 kV line outage.

When load growth in the system demands system improvement, in approximately 2022 timeframe, the Elko to New Market to Veseli 69 kV line will be operated at 115 kV with the installation of a 115/69 kV substation at Veseli. Upon the completion of this project, an additional 22 MW load, on top of the expected 2020/2022 load levels, will be served prior to the system experiencing equipment loading or low voltage concerns. At that time, the Lake Marion to Elko 69 kV line will need to be upgraded to 115 kV standards. This line does not currently experience the immediate overload concerns identified on the other 69 kV lines that need to be rebuilt at this time.

The next project in the system will be required after 37 MW incremental load from the 2016 load level. At this load level the Gifford Lake area will start to experience low voltage concern, and after 43 MW incremental load, the Carver County to Assumption 69 kV line will start to experience overload concerns. This load level, according to the current trend, will be seen, approximately, between the 2027 and 2030 timeframe. At that time, the New Market to Spring Lake to Credit River 69-kV line will need to be upgraded to 115 kV standards.

The long-term plan to address the long-term deficiencies is to rebuild the Carver County to Assumption to Belle Plain 69 kV line with 795 ACSS to 115 kV standards and to loop the Lake Marion to Elko to Veseli 115 kV radial line to the Glendale 115 kV bus. Loads served on the northern part of the Lake Marion to Glendale 69 kV system is expected to grow faster and any new construction including distribution substation high sides upgrades or new rebuilds in the system should be done to 115 kV standard.

The system will continue to be monitored as part GRE's annual detailed assessment studies. When system needs arise, the proposed projects will be constructed prior to the system experiences violations.

## **9. Conclusion**

The preferred and best value plan is Option 2(b), which rebuilds existing old, high impedance, and low capacity 69 kV transmission lines with new, low impedance and high capacity transmission line that is ready for future operations at 115 kV. This option will construct a double circuit 69 kV line from the New Market area that connects to a new breaker station at the existing Veseli distribution substation site. This connection will introduce two sources, the Glendale and Lake Marion 115/69 kV sources, to the load center where support is needed.

The new construction and rebuilds will be done to 115 kV standards. When load growth in the system requires system improvement, a new 115/69 kV substation will be installed at Veseli along with the conversion of the Lake Marion to Veseli line to 115 kV operation. The Elko distribution substation will be upgraded to receive 115 kV service upon the 115 kV operation of the Lake Marion to Veseli transmission line.

The installation of the Jordan breaker station at the intersection of the lines from Scott County, Carver County, and New Prague will eliminate the creation of four terminal lines. This breaker station will bring more operational flexibility and provide significant

reliability improvement to loads served on the 69 kV system between Scott County, Carver County and New Prague.

The study area will be served reliably for a long-term upon the installation of all recommended facilities in the preferred option, Option 2(b). The next phase of the project, such as conversion of to 115 kV operations, will be considered when load growth in the system requires it.



**Appendix A: System Historical Load**

**GRE Historical Peak Loads**

Substation	Historical Peak Loads in KW										Applied Growth Rate	2012 SUPK		2016 SUPK	
	2003	2004	2005	2006	2007	2008	2009	2010	2011	2012		KW	KVAR	KW	KVAR
New Prague	5,548	4,710	5,477	6,901	6,389	6,543	6,561	7,283	7,719	7,190	3.00%	7719	1567	8690	1760
Merriam Jct	6,550	6,238	6,943	8,152	7,104	4,466	4,288	6,538	4,928	6,272	1.50%	6538	1001	8940	1820
Prior Lake N	18,238	10,114	11,772	11,085	11,459	10,550	9,864	8,552	9,159	11,078	2.00%	11078	1860	11990	2430
Assumption	1,908	1,578	1,777	1,953	2,569	1,833	1,689	1,936	1,860	2,455	3.00%	2455	378	2760	560
New Market	10,263	9,017	4,753	5,560	4,333	3,483	3,281	3,861	4,122	4,002	2.00%	4122	837	4460	910
Spring Lake	9,166	8,114	9,231	10,617	6,123	4,740	4,431	5,398	5,789	5,686	3.00%	5789	1176	6520	1320
Gifford Lake		3,500	3,949	2,420	3,609	2,748	3,653	2,642	2,510	3,013	2.00%	3653	510	3950	800
Elko			5,459	9,858	9,354	9,426	9,030	10,419	10,551	10,974	7.00%	10974	2142	14380	2920
Cleary Lake					6,436	6,834	6,982	11,136	11,102	11,216	5.00%	11216	2254	13630	2770
Sand Creek						4,344	4,294	2,844	5,132	5,148	3.00%	5148	1042	5790	1180
Prior Lake S	14,866	17,652	15,902	16,600	15,474	14,829	14,465	13,808	14,797	15,429	2.00%	15429	3005	16700	3390
French Lake	683	1,451	2,406	1,548	2,339	1,432	1,681	2,485	2,558	2,750	3.00%	2750	519	3100	630

### SMMPA Peak Load

Substations	Historical Peak Loads in KW										2012 SUPK		Applied Growth Rate	2016 SUPK	
	2003	2004	2005	2006	2007	2008	2009	2010	2011	2012	MW	KVAR		MW	KVAR
New Prague Muni1	4210	4848	N/A	5395	7113	5424	9849	5683	5116	5692	4600	940	0.8%	4800	940
New Prague Muni 2	9632	9120	N/A	9395	9907	9280	10291	10053	10206	9991	8600	1740	0.8%	8900	1820
New Prague NCP	12943	12913	13845	13954	13865	13632	13501	13504	15017	14062	14062				

### ITCM –ALLIANT Peak Load

Substation	Historical Peak Loads in KW										2012 SUPK		Growth Rate Per Year	2016 SUPK	
	2003	2004	2005	2006	2007	2008	2009	2010	2011	2012	KW	KVAR		KW	KVAR
Montgomery	8400	8500	8800	9980	9300	8500	8000	9100	8800	8500	8500	2500	0.25%	8600	2500

### XCEL Energy Peak Loads

Substation	Historical Peak Loads in KW										2012 SUPK		Applied Growth Rate	2016 SUPK	
	2003	2004	2005	2006	2007	2008	2009	2010	2011	2012	KW	KVAR		KW	KVAR
Credit River	13610	13370	15500	17070	17451	16057	14633	16720	17626	17140	3480	1%	18997	3858	
Veseli	7040	7080	8895	4150	4192	5301	5301	5952	6012	6394	1298	1%	6250	1269	
Jordan	7560	7140	8760	9343	8789	8220	8220	7895	8623	9749	1980	1%	9770	1984	
Belle Plaine	9160	9620	9993	12758	14126	13002	13002	15576	13945	14815	3008	1%	16370	3324	

**Appendix B: System Base Load for Incremental Load**

Incremental Load Analysis

2016 Peak loads used for incremental load analysis

Bus Number	Substation	MW	MVAR
605141	VESELI 8 69.000	6.25	1.269
605142	JORDAN 8 69.000	9.77	1.984
605143	BELPLAN8 69.000	16.37	3.324
605189	CRDTRIV8 69.000	19	3.858
613190	NEW PRAG 69.000	8.9	1.82
613200	NEWPRAGN 69.000	4.8001	0.98
618715	GRE-ELKO 869.000	14.38	2.92
618716	GRE-GIFFDLK869.000	3.95	0.8
618718	GRE-SANDCRK869.000	5.79	1.18
618724	GRE-ASSMPTN869.000	2.76	0.56
618726	GRE-PRIORLK869.000	28.69	5.82
618732	GRE-CLRY LK869.000	13.63	2.77
618733	GRE-MERRIAM869.000	8.94	1.82
618737	GRE-NWMARKT869.000	4.46	0.91
618738	GRE-SPRINGL869.000	6.52	1.32
619634	GRE-FRNCHLK869.000	3.1	0.63
630134	MONTGMY8 69.000	7.26	1.98
630135	NEWPRAG8 69.000	8.69	1.76
Total		173.3	35.7

**Appendix C: Contingency analysis results of existing system**

Existing conditions - MRO 2012 Summer Peak

**Voltage violations**

2012 Summer Peak Low Voltages							
CONTINGENCY PERFORMED FROM TO CKT			SUBSTATION # NAME KV OWNER		VOLTAGE %	DROP %	
SYSTEM INTACT			605141 VESELI 8	69.0	600	96.21	
			605142 JORDAN 8	69.0	600	100.03	
			605143 BELPLAN8	69.0	600	99.45	
			605144 NPG TAP8	69.0	600	97	
			605280 NPR TAP8	69.0	600	97	
			613190 NEW PRAG	69.0	613	96.93	
			613200 NEWPRAGN	69.0	613	97.91	
			618716 GRE-GIFFDLK8	69.0	615	101.52	
			618717 GRE-SNDCRKT8	69.0	615	98.96	
			618718 GRE-SANDCRK8	69.0	615	98.8	
			618733 GRE-MERRIAM8	69.0	615	100.66	
			619633 GRE-FRLK TP8	69.0	615	98.76	
			619634 GRE-FRNCHLK8	69.0	615	98.54	
			629054 MONTGG19	13.8	627	97.74	
			630134 MONTGMY8	69.0	627	97.74	
			630135 NEWPRAG8	69.0	627	97.11	
605142 JORDAN 8 69.00 618733 GRE-MERRIAM869.00 1			605141 VESELI 8	69.0	600	88.63	7.57
			605142 JORDAN 8	69.0	600	90.77	9.26
			605143 BELPLAN8	69.0	600	92.29	7.16
			605144 NPG TAP8	69.0	600	89.5	7.5
			605280 NPR TAP8	69.0	600	89.5	7.5
			613190 NEW PRAG	69.0	613	89.4	7.53
			613200 NEWPRAGN	69.0	613	89.51	8.4
			618717 GRE-SNDCRKT8	69.0	615	90.03	8.93
			618718 GRE-SANDCRK8	69.0	615	89.86	8.94
605244 SCOTTCO8 69.00 618716 GRE-GIFFDLK869.00 1			605141 VESELI 8	69.0	600	85.23	10.98
			605142 JORDAN 8	69.0	600	86.74	13.29
			605143 BELPLAN8	69.0	600	89.13	10.32
			605144 NPG TAP8	69.0	600	86.13	10.87
			605280 NPR TAP8	69.0	600	86.13	10.87
			613190 NEW PRAG	69.0	613	86.02	10.91
			613200 NEWPRAGN	69.0	613	85.8	12.11
			618716 GRE-GIFFDLK8	69.0	615	86.4	15.12
			618717 GRE-SNDCRKT8	69.0	615	86.12	12.84
			618718 GRE-SANDCRK8	69.0	615	85.94	12.86
			618733 GRE-MERRIAM8	69.0	615	86.5	14.17
			619633 GRE-FRLK TP8	69.0	615	92.49	6.27
			619634 GRE-FRNCHLK8	69.0	615	92.26	6.28
			629054 MONTGG19	13.8	627	88.66	9.08
			630134 MONTGMY8	69.0	627	88.66	9.08
			630135 NEWPRAG8	69.0	627	86.62	10.49
605280 NPR TAP8 69.00 613200 NEWPRAGN 69.00 1			605141 VESELI 8	69.0	600	85.26	10.95
			605144 NPG TAP8	69.0	600	86.16	10.84
			605280 NPR TAP8	69.0	600	86.16	10.84
			613190 NEW PRAG	69.0	613	86.05	10.88
			619633 GRE-FRLK TP8	69.0	615	92.15	6.6
			619634 GRE-FRNCHLK8	69.0	615	91.92	6.62
			629054 MONTGG19	13.8	627	88.55	9.19
			630134 MONTGMY8	69.0	627	88.55	9.19
			630135 NEWPRAG8	69.0	627	86.63	10.48

**Continued ...**

613200 NEWPRAGN 69.00 618717 GRE-SNDCRKT869.00 1	605141 VESELI 8            69.0    600 605144 NPG TAP8            69.0    600 605280 NPR TAP8            69.0    600 613190 NEW PRAG            69.0    613 613200 NEWPRAGN           69.0    613 619633 GRE-FRLK TP8        69.0    615 619634 GRE-FRNCHLK8       69.0    615 629054 MONTGG19            13.8    627 630134 MONTGMY8            69.0    627 630135 NEWPRAG8            69.0    627	75.11    21.1 76.14    20.87 76.14    20.86 75.98    20.95 75.13    22.78 86.6      12.16 86.35    12.19 80.16    17.59 80.16    17.59 76.93    20.18
618716 GRE-GIFFDLK869.00 618733 GRE-MERRIAM869.00 1	605141 VESELI 8            69.0    600 605142 JORDAN 8            69.0    600 605143 BELPLAN8            69.0    600 605144 NPG TAP8            69.0    600 605280 NPR TAP8            69.0    600 613190 NEW PRAG            69.0    613 613200 NEWPRAGN           69.0    613 618717 GRE-SNDCRKT8        69.0    615 618718 GRE-SANDCRK8       69.0    615 618733 GRE-MERRIAM8       69.0    615 619633 GRE-FRLK TP8        69.0    615 619634 GRE-FRNCHLK8       69.0    615 629054 MONTGG19            13.8    627 630134 MONTGMY8            69.0    627 630135 NEWPRAG8            69.0    627	86.62    9.58 88.38    11.65 90.45    9 87.51    9.49 87.51    9.49 87.4      9.53 87.31    10.6 87.72    11.24 87.54    11.26 88.23    12.43 93.29    5.47 93.06    5.48 89.82    7.92 89.82    7.92 87.95    9.16
619633 GRE-FRLK TP869.00 630133 WASECAJ8 69.00 1	613200 NEWPRAGN           69.0    613 619633 GRE-FRLK TP8        69.0    615 619634 GRE-FRNCHLK8       69.0    615 629054 MONTGG19            13.8    627 630134 MONTGMY8            69.0    627 630135 NEWPRAG8            69.0    627	93.31    4.6 88.32    10.44 88.08    10.47 88.85    8.89 88.85    8.89 89.53    7.59
Jordan - Sand Creek 69 kV line outage	CASE DIDN'T SOLOVE – VOLTAGE TOO LOW	

## 2012 SUPK Branch Overloads

BRANCH	SI RATE MVA	CONT RATE MVA	LOADG %I	CURRENT MVA	CONTINGENCY FROM TO CKT
605142 JORDAN 8 69.00 618717 GRE-SNDCRKT869.00 1	48.0	48.0	50.9 98 90	24.43 47.04 43.21	SYSTEM INTACT 619633 GRE-FRLK TP869.00 630133 WASECAJ8 69.00 1 619633 GRE-FRLK TP869.00 630134 MONTGMY8 69.00 1
605143 BELPLAN8 69.00 618724 GRE-ASSMPTN869.00 1	45.4	45.4	44 100.8 124.3 115.4	20 45.75 56.43 52.41	SYSTEM INTACT 605142 JORDAN 8 69.00 618733 GRE-MERRIAM869.00 1 605244 SCOTTCO8 69.00 618716 GRE-GIFFDLK869.00 1 618716 GRE-GIFFDLK869.00 618733 GRE-MERRIAM869.00
605275 CARVRCO8 69.00 618724 GRE-ASSMPTN869.00 1	45.4	45.4	49.3 106.3 129.9 121	22.36 48.27 58.97 54.94	SYSTEM INTACT 605142 JORDAN 8 69.00 618733 GRE-MERRIAM869.00 1 605244 SCOTTCO8 69.00 618716 GRE-GIFFDLK869.00 1 618716 GRE-GIFFDLK869.00 618733 GRE-MERRIAM869.00
605280 NPR TAP8 69.00 630135 NEWPRAG8 69.00 1	35.0	35.0	8.1 72.5	2.84 25.38	SYSTEM INTACT 613200 NEWPRAGN 69.00 618717 GRE-SNDCRKT869.00
619633 GRE-FRLK TP869.00 630133 WASECAJ8 69.00 1	36.0	36.0	55 80.4 91.3 104.6 131.6 87	19.81 28.96 32.87 37.66 47.39 31.33	SYSTEM INTACT 605142 JORDAN 8 69.00 618733 GRE-MERRIAM869.00 1 605244 SCOTTCO8 69.00 618716 GRE-GIFFDLK869.00 1 605280 NPR TAP8 69.00 613200 NEWPRAGN 69.00 1 613200 NEWPRAGN 69.00 618717 GRE-SNDCRKT869.00 618716 GRE-GIFFDLK869.00 618733 GRE-MERRIAM869.00
619633 GRE-FRLK TP869.00 630134 MONTGMY8 69.00 1	36.0	36.0	47.6 72.4 83 96.4 122.7 78.9	17.15 26.07 29.89 34.72 44.18 28.4	SYSTEM INTACT 605142 JORDAN 8 69.00 618733 GRE-MERRIAM869.00 1 605244 SCOTTCO8 69.00 618716 GRE-GIFFDLK869.00 1 605280 NPR TAP8 69.00 613200 NEWPRAGN 69.00 1 613200 NEWPRAGN 69.00 618717 GRE-SNDCRKT869.00 618716 GRE-GIFFDLK869.00 618733 GRE-MERRIAM869.00
630134 MONTGMY8 69.00 630135 NEWPRAG8 69.00 1	36.0	36.0	25.3 73.2 98.4	9.11 26.36 35.43	SYSTEM INTACT 605280 NPR TAP8 69.00 613200 NEWPRAGN 69.00 1 613200 NEWPRAGN 69.00 618717 GRE-SNDCRKT869.00
CASE DID NOT SOLVE	Voltage Too Low			Jordan to New Prague outage	

**Appendix D: Contingency Analysis results of Future System**

MRO 2016 Summer Peak

**Voltage Violations**

UNDERVOLTAGE								
CONTINGENCY PERFORMED			SUBSTATION		VOLTAGE	DROP		
FROM	TO	CKT	#	NAME	KV	OWNER	%	%
SYSTEM INTACT			605141	VESELI 8	69.0	600	96.73	
			605142	JORDAN 8	69.0	600	100.48	
			605143	BELPLAN8	69.0	600	100.12	
			605144	NPG TAP8	69.0	600	97.54	
			605280	NPR TAP8	69.0	600	97.54	
			613190	NEW PRAG	69.0	613	97.46	
			613200	NEWPRAGN	69.0	613	97.67	
			618716	GRE-GIFFDLK8	69.0	615	101.86	
			618717	GRE-SNDCRKT8	69.0	615	99.3	
			618718	GRE-SANDCRK8	69.0	615	99.12	
			618733	GRE-MERRIAM8	69.0	615	101.03	
			618738	GRE-SPRINGL8	69.0	615	99.81	
			619633	GRE-FRLK TP8	69.0	615	99.52	
			619634	GRE-FRNCHLK8	69.0	615	99.28	
			629054	MONTGG19	13.8	627	98.35	
			630133	WASECAJ8	69.0	627	101.8	
630134	MONTGMY8	69.0	627	98.35				
630135	NEWPRAG8	69.0	627	97.64				
605142 JORDAN 8 69.00 618717 GRE-SNDCRKT869.00 1			605141	VESELI 8	69.0	600	50.15	46.58
			605144	NPG TAP8	69.0	600	51.47	46.08
			605280	NPR TAP8	69.0	600	51.47	46.08
			613190	NEW PRAG	69.0	613	51.19	46.28
			613200	NEWPRAGN	69.0	613	51.09	46.58
			618717	GRE-SNDCRKT8	69.0	615	49.71	49.59
			618718	GRE-SANDCRK8	69.0	615	49.41	49.71
			619633	GRE-FRLK TP8	69.0	615	73	26.52
			619634	GRE-FRNCHLK8	69.0	615	72.66	26.62
			629054	MONTGG19	13.8	627	59.25	39.1
			630133	WASECAJ8	69.0	627	92.4	9.4
			630134	MONTGMY8	69.0	627	59.25	39.1
			630135	NEWPRAG8	69.0	627	52.93	44.71

Continued...

605142 JORDAN 8 69.00 618733 GRE-MERRIAM869.00 1	605142 JORDAN 8	69.0	600	90.27	10.21
	605143 BELPLAN8	69.0	600	91.95	8.17
	613200 NEWPRAGN	69.0	613	88.63	9.04
	618717 GRE-SNDCRKT8	69.0	615	89.45	9.85
	618718 GRE-SANDCRK8	69.0	615	89.25	9.87
605244 SCOTTO8 69.00 618716 GRE-GIFFDLK869.00 1	605141 VESELI 8	69.0	600	83.01	13.71
	605142 JORDAN 8	69.0	600	85.14	15.34
	605143 BELPLAN8	69.0	600	88.02	12.11
	605144 NPG TAP8	69.0	600	83.97	13.57
	605280 NPR TAP8	69.0	600	83.97	13.57
	613190 NEW PRAG	69.0	613	83.83	13.63
	613200 NEWPRAGN	69.0	613	83.92	13.75
	618716 GRE-GIFFDLK8	69.0	615	84.72	17.15
	618717 GRE-SNDCRKT8	69.0	615	84.44	14.86
	618718 GRE-SANDCRK8	69.0	615	84.23	14.89
	618733 GRE-MERRIAM8	69.0	615	84.82	16.21
	619633 GRE-FRLK TP8	69.0	615	91.64	7.88
	619634 GRE-FRNCHLK8	69.0	615	91.37	7.9
	629054 MONTGG19	13.8	627	86.96	11.39
630134 MONTGMY8	69.0	627	86.96	11.39	
630135 NEWPRAG8	69.0	627	84.53	13.12	
605280 NPR TAP8 69.00 613200 NEWPRAGN 69.00 1	605141 VESELI 8	69.0	600	84.38	12.35
	605144 NPG TAP8	69.0	600	85.32	12.22
	605280 NPR TAP8	69.0	600	85.32	12.22
	613190 NEW PRAG	69.0	613	85.19	12.27
	619633 GRE-FRLK TP8	69.0	615	92.19	7.33
	619634 GRE-FRNCHLK8	69.0	615	91.93	7.35
	629054 MONTGG19	13.8	627	88	10.34
	630134 MONTGMY8	69.0	627	88	10.34
	630135 NEWPRAG8	69.0	627	85.82	11.82

Continued...

613200 NEWPRAGN 69.00 618717 GRE-SNDCRKT869.00 1	605141 VESELI 8	69.0	600	68.83	27.89
---	-----------------	------	-----	-------	-------



	605144 NPG TAP8	69.0	600	69.99	27.55
	605280 NPR TAP8	69.0	600	69.99	27.55
	613190 NEW PRAG	69.0	613	69.78	27.68
	613200 NEWPRAGN	69.0	613	69.84	27.83
	619633 GRE-FRLK TP8	69.0	615	83.27	16.25
	619634 GRE-FRNCHLK8	69.0	615	82.98	16.3
	629054 MONTGG19	13.8	627	74.94	23.4
	630134 MONTGMY8	69.0	627	74.94	23.4
	630135 NEWPRAG8	69.0	627	70.92	26.72
615441 GRE-LKMARN 869.00 618736 GRE-LKMRNTP869.00 1	618738 GRE-SPRINGL8	69.0	615	94.82	4.99
618716 GRE-GIFFDLK869.00 618733 GRE-MERRIAM869.00 1	605141 VESELI 8	69.0	600	84.45	12.27
	605142 JORDAN 8	69.0	600	86.69	13.79
	605143 BELPLAN8	69.0	600	89.17	10.95
	605144 NPG TAP8	69.0	600	85.39	12.15
	605280 NPR TAP8	69.0	600	85.39	12.15
	613190 NEW PRAG	69.0	613	85.27	12.2
	613200 NEWPRAGN	69.0	613	85.36	12.31
	618717 GRE-SNDCRKT8	69.0	615	85.96	13.34
	618718 GRE-SANDCRK8	69.0	615	85.75	13.37
	618733 GRE-MERRIAM8	69.0	615	86.47	14.56
	629054 MONTGG19	13.8	627	88.17	10.17
	630134 MONTGMY8	69.0	627	88.17	10.17
	630135 NEWPRAG8	69.0	627	85.91	11.73
619633 GRE-FRLK TP869.00 630133 WASECAJ8 69.00 1	619633 GRE-FRLK TP8	69.0	615	90.64	8.87
	619634 GRE-FRNCHLK8	69.0	615	90.38	8.9

Continued...

613200 NEWPRAGN 69.00 618717 GRE-SNDCRKT869.00 1	605141 VESELI 8	69.0	600	68.83	27.89
	605144 NPG TAP8	69.0	600	69.99	27.55
	605280 NPR TAP8	69.0	600	69.99	27.55
	613190 NEW PRAG	69.0	613	69.78	27.68
	613200 NEWPRAGN	69.0	613	69.84	27.83
	619633 GRE-FRLK TP8	69.0	615	83.27	16.25
	619634 GRE-FRNCHLK8	69.0	615	82.98	16.3
	629054 MONTGG19	13.8	627	74.94	23.4
	630134 MONTGMY8	69.0	627	74.94	23.4
	630135 NEWPRAG8	69.0	627	70.92	26.72
615441 GRE-LKMARN 869.00 618736 GRE-LKMRNTP869.00 1	618738 GRE-SPRINGL8	69.0	615	94.82	4.99
618716 GRE-GIFFDLK869.00 618733 GRE-MERRIAM869.00 1	605141 VESELI 8	69.0	600	84.45	12.27
	605142 JORDAN 8	69.0	600	86.69	13.79
	605143 BELPLAN8	69.0	600	89.17	10.95
	605144 NPG TAP8	69.0	600	85.39	12.15
	605280 NPR TAP8	69.0	600	85.39	12.15
	613190 NEW PRAG	69.0	613	85.27	12.2
	613200 NEWPRAGN	69.0	613	85.36	12.31
	618717 GRE-SNDCRKT8	69.0	615	85.96	13.34
	618718 GRE-SANDCRK8	69.0	615	85.75	13.37
	618733 GRE-MERRIAM8	69.0	615	86.47	14.56
	629054 MONTGG19	13.8	627	88.17	10.17
	630134 MONTGMY8	69.0	627	88.17	10.17
630135 NEWPRAG8	69.0	627	85.91	11.73	
619633 GRE-FRLK TP869.00 630133 WASECAJ8 69.00 1	619633 GRE-FRLK TP8	69.0	615	90.64	8.87
	619634 GRE-FRNCHLK8	69.0	615	90.38	8.9

## 2016 SUPK BRANCH OVERLOADS

CIRCUIT/WINDING #	TO #	TO NAME	CKT #	SI RATE MVA	LOADG %I	CURRENT MVA	CONTINGENCY FROM	TO	CKT
605142 JORDAN 8	69.00	618717 GRE-SNDCRKT	869.00 1	48.0	53.1 102.4 94.1	25.51 49.17 45.15	SYSTEM INTACT 619633 GRE-FRLK TP869.00 630133 WASECAJ8	69.00 1	619633 GRE-FRLK TP869.00 630134 MONTGMY8 69.00 1
605143 BELPLAN8	69.00	618724 GRE-ASSMPTN	869.00 1	45.4	37.9 101.8 132.4 122.5	17.19 46.19 60.11 55.62	SYSTEM INTACT 605142 JORDAN 8 69.00 618733 GRE-MERRIAM869.00 1 605244 SCOTTCO8 69.00 618716 GRE-GIFFDLK869.00 1 618716 GRE-GIFFDLK869.00 618733 GRE-MERRIAM869.00 1		
605275 CARVRCO8	69.00	618724 GRE-ASSMPTN	869.00 1	45.4	43.9 108 138.7 128.8	19.91 49.02 62.96 58.47	SYSTEM INTACT 605142 JORDAN 8 69.00 618733 GRE-MERRIAM869.00 1 605244 SCOTTCO8 69.00 618716 GRE-GIFFDLK869.00 1 618716 GRE-GIFFDLK869.00 618733 GRE-MERRIAM869.00 1		
605280 NPR TAP8	69.00	630135 NEWPRAG8	69.00 1	35.0	7.2 121.1 82.1	2.52 42.39 28.73	SYSTEM INTACT 605142 JORDAN 8 69.00 618717 GRE-SNDCRKT869.00 1 613200 NEWPRAGN 69.00 618717 GRE-SNDCRKT869.00 1		
613200 NEWPRAGN	69.00	618717 GRE-SNDCRKT	869.00	48.0	41.3 90.1	19.82 43.26	SYSTEM INTACT 619633 GRE-FRLK TP869.00 630133 WASECAJ8	69.00 1	
615542 GRE-GLNDALE869.00	618735	GRE-PRLKJCT	869.00	68.1	23.5 90	16.03 61.3	SYSTEM INTACT 615441 GRE-LKMARN 869.00 618736 GRE-LKMRNTP869.00 1		
618735 GRE-PRLKJCT869.00	618739	GRE-CRDRVTP	869.00	68.1	23.7 90	16.11 61.32	SYSTEM INTACT 615441 GRE-LKMARN 869.00 618736 GRE-LKMRNTP869.00 1		
619633 GRE-FRLK TP869.00	630133	WASECAJ8	69.00 1	36.0	59.5 199.3 107.6 111.9 150.6 102.8	21.41 71.75 38.74 40.27 54.23 37.02	SYSTEM INTACT 605142 JORDAN 8 69.00 618717 GRE-SNDCRKT869.00 1 605244 SCOTTCO8 69.00 618716 GRE-GIFFDLK869.00 1 605280 NPR TAP8 69.00 613200 NEWPRAGN 69.00 1 613200 NEWPRAGN 69.00 618717 GRE-SNDCRKT869.00 1 618716 GRE-GIFFDLK869.00 618733 GRE-MERRIAM869.00 1		
619633 GRE-FRLK TP869.00	630134	MONTGMY8	69.00 1	36.0	51.2 187.7 98.2 102.6 140.2 93.5	18.43 67.56 35.34 36.93 50.46 33.67	SYSTEM INTACT 605142 JORDAN 8 69.00 618717 GRE-SNDCRKT869.00 1 605244 SCOTTCO8 69.00 618716 GRE-GIFFDLK869.00 1 605280 NPR TAP8 69.00 613200 NEWPRAGN 69.00 1 613200 NEWPRAGN 69.00 618717 GRE-SNDCRKT869.00 1 618716 GRE-GIFFDLK869.00 618733 GRE-MERRIAM869.00 1		
630134 MONTGMY8	69.00	630135 NEWPRAG8	69.00 1	36.0	28.3 156.5 74.6 78.6 113.6 70.1	10.18 56.35 26.84 28.29 40.88 25.24	SYSTEM INTACT 605142 JORDAN 8 69.00 618717 GRE-SNDCRKT869.00 1 605244 SCOTTCO8 69.00 618716 GRE-GIFFDLK869.00 1 605280 NPR TAP8 69.00 613200 NEWPRAGN 69.00 1 613200 NEWPRAGN 69.00 618717 GRE-SNDCRKT869.00 1 618716 GRE-GIFFDLK869.00 618733 GRE-MERRIAM869.00 1		

**APPENDIX E: P-V Curves with Option 2(a)**

Option 2(a) : Incremental Load Serving Capability PV-Plots

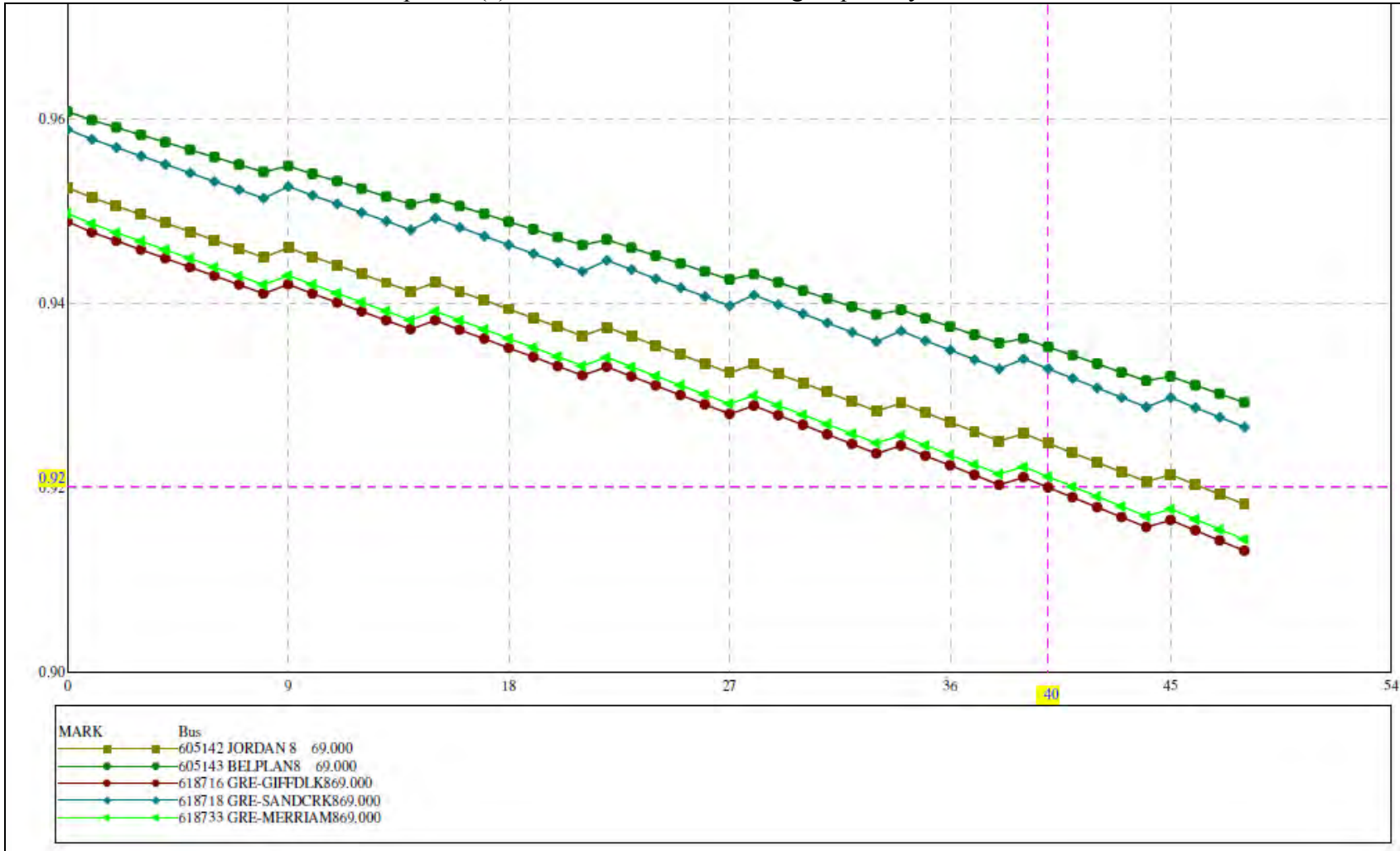

Figure E.1: Option 2a- Low voltage Limit after 40 MW incremental load due to Scott County to Gifford Lake 69 kV line outage

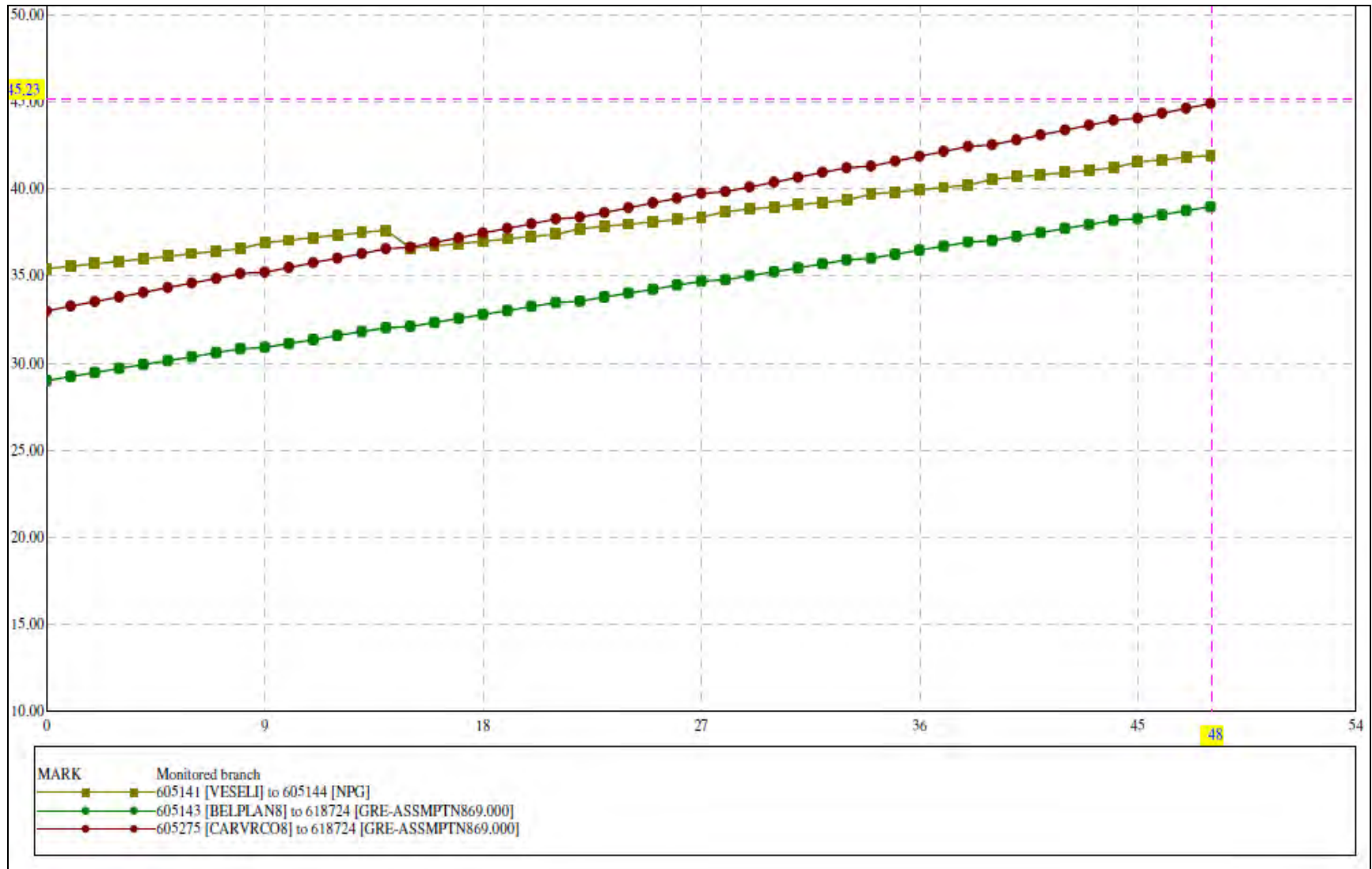

Figure E.2: Option 2a- Branch Loading Limit after 48 MW incremental load due to Scott County to Gifford Lake 69 kV line outage

**APPENDIX F: P-V Curves with Option 2(b)**

Option 2 (b) Incremental load serving Capability prior to the installation of the 115/69 kV transformer at Veseli

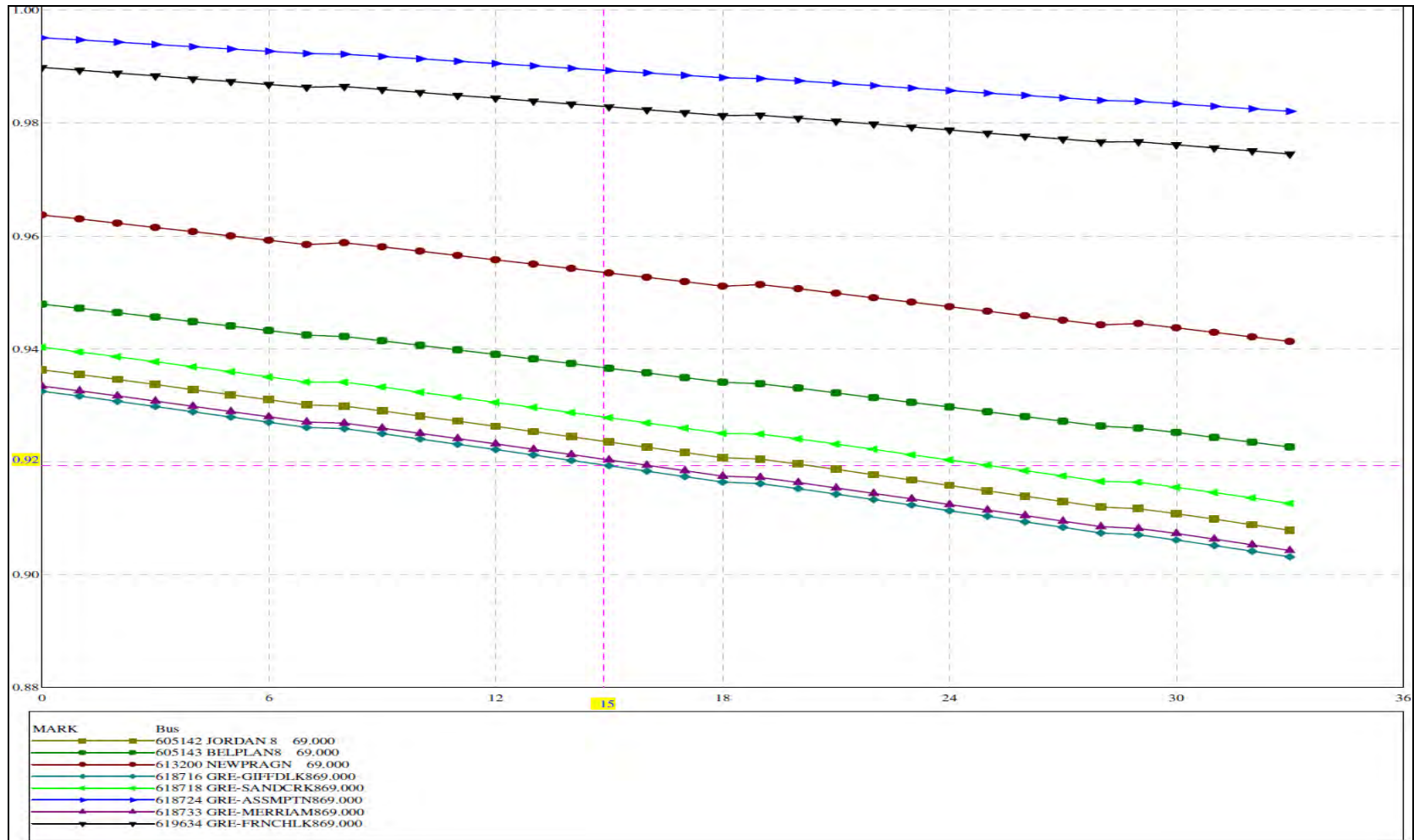

Figure F.1: Option 2 (b)- Low voltage Limit after 15 MW incremental load due to Scott County to Gifford Lake 69 kV line outage

Option 2 (b) Incremental load serving Capability After the installation of the 115/69 kV transformer at Veseli

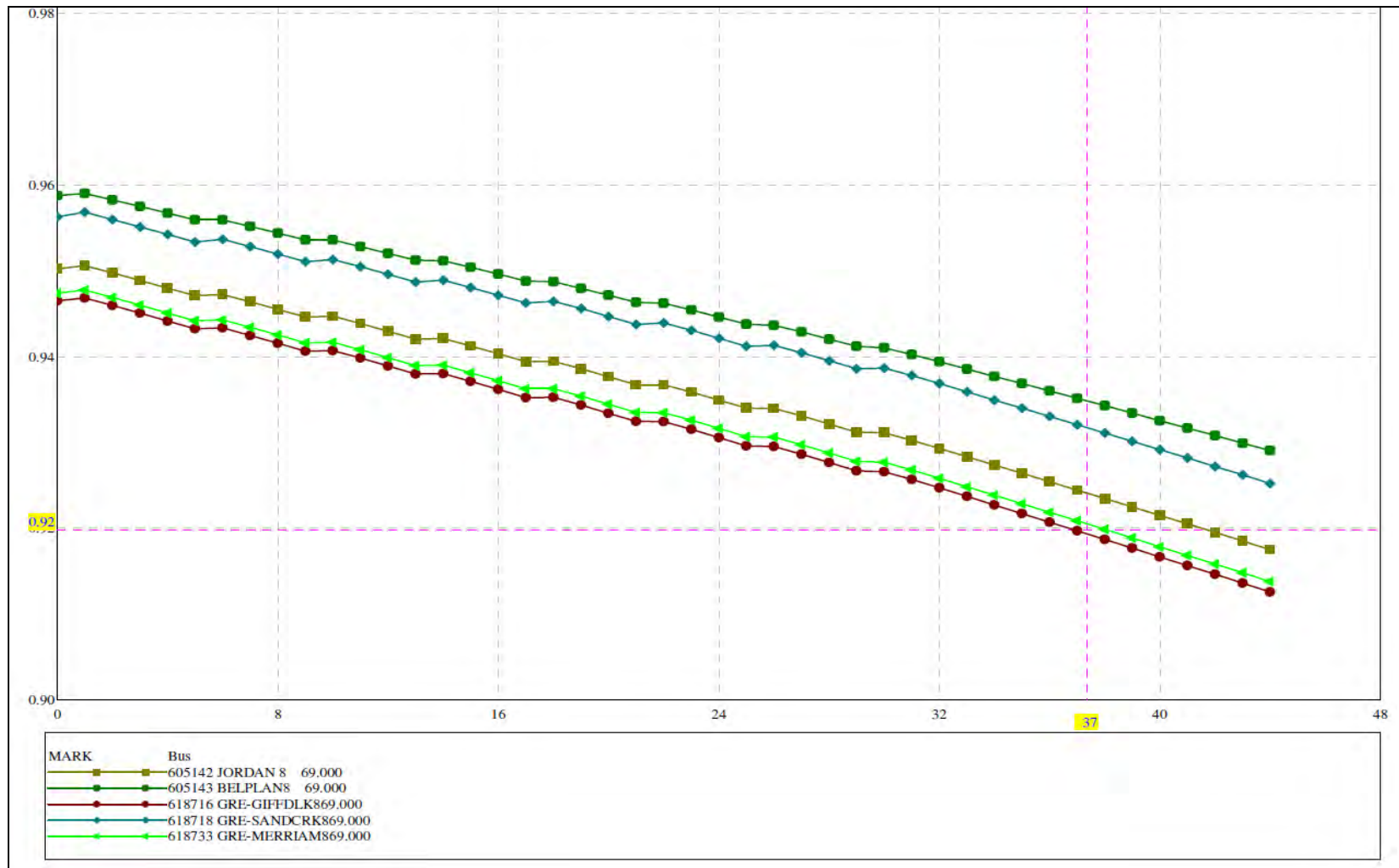

Figure F.2: Option 2(b) - Low voltage Limit after 37 MW incremental load due to Scott County to Gifford Lake 69 kV line outage

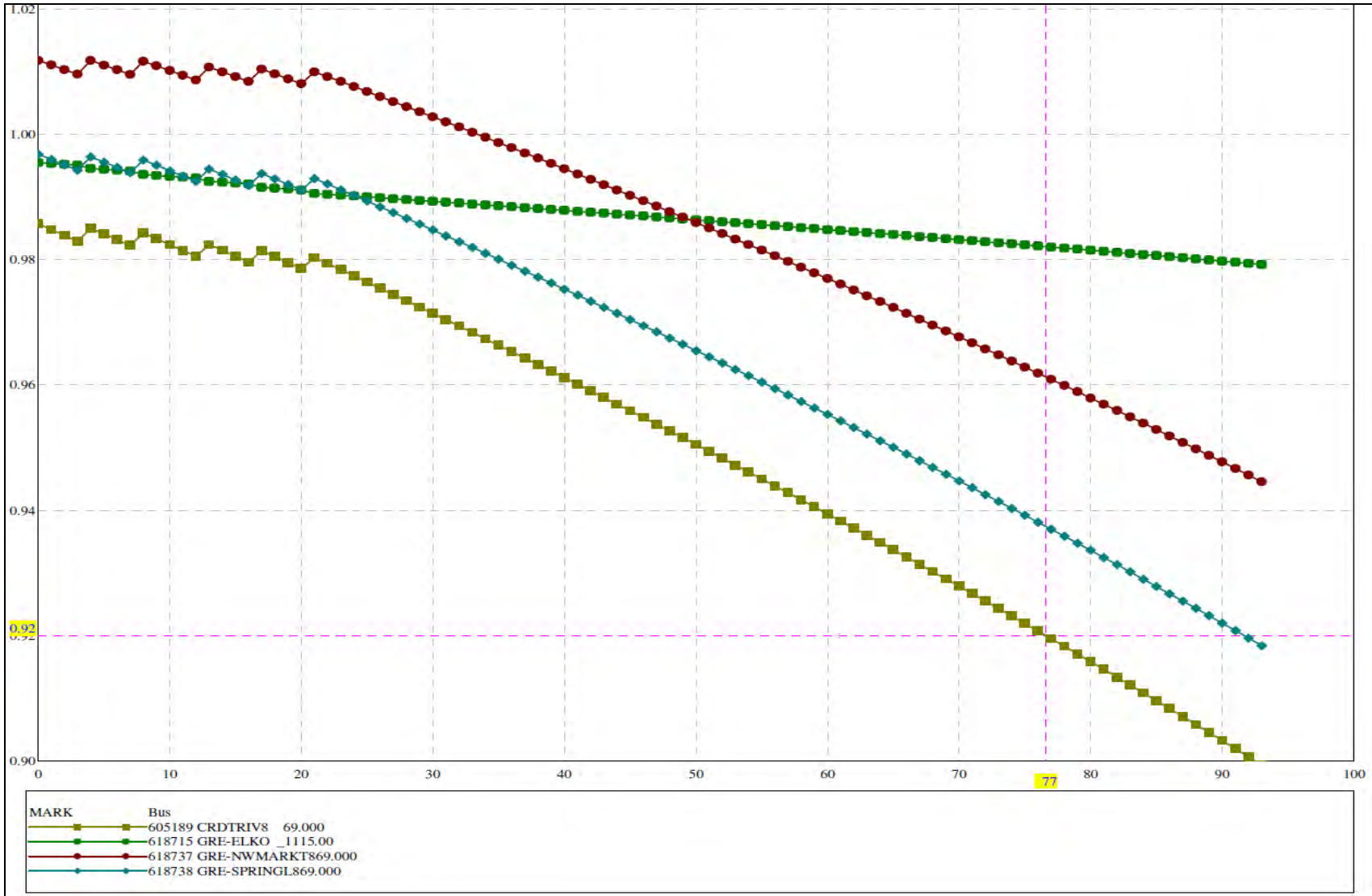

Figure F.3: Option 2(b)- Low voltage limit after 45 MW incremental load due to Credit River to Cleary Lake 69 kV line outage



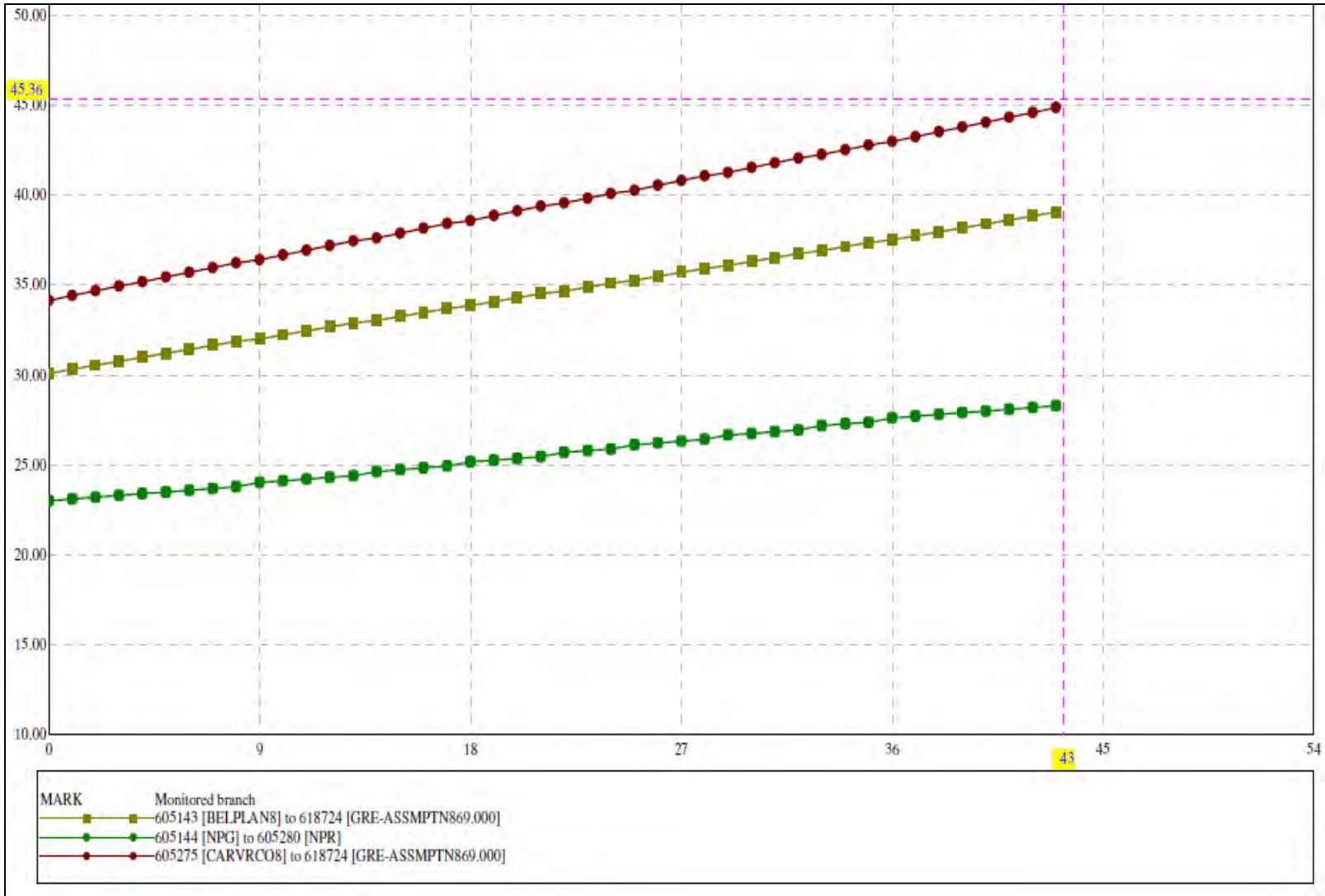

Figure F.4: Option 2(b)- Branch Loading limit after 43 MW incremental load due to Scott County to Gifford Lake 69 kV line outage

**APPENDIX G: Present Worth Table**

**Present worth spreadsheet for Option 2(a)**

		Present Worth Years 41	Cumulative Present Worth 32327	Cumulative Investment 20438	Annual Cost 2135							
The following rates will be assessed in the analysis:												
Investment: Capital Recovery:		Dist: 7.50%	Lines: 7.50%	Subs: 7.50%	Interest Rate: Investment Esc.: 6.00%			Year of study: 2012				
Property Tax:		3.50%	3.50%	3.50%	Expense Esc.: 4.00%			Year of dollar: 2012				
O&M:		2.00%	2.00%	2.00%								
G&A:		0.80%	0.80%	0.80%								
Insurance:		0.10%	0.00%	0.10%	Losses (\$/kW/yr.):	\$ 315.65						
Charge Rate:		13.90%	13.80%	13.90%					Costs are in: 1000's			
Year	Dist. Invest. 2012 Dollars	Lines Invest. 2012 Dollars	Subs. Invest. 2012 Dollars	Escalated New Invest.	Expenses 2012 Dollars	Escalated Expenses	Investment Revenue Requirement	Revenue Require.	Present Worth of Revenue Requirement	Cumulative PW 2012 Dollars	Cumulative Investment	
2012	0	0	0	0	0	0	\$0	0	0	0	0	
2013	0	0	0	0	0	0	\$0	0	0	0	0	
2014	0	0	0	0	0	0	\$0	0	0	0	0	
2015	0	0	0	0	0	0	\$0	0	0	0	0	
2016	0	8384	7031	18737	0	0	\$2,594	2594	2055	2055	18737	
2017	0	0	0	0	-126	-154	\$2,594	2441	1824	3879	18737	
2018	0	0	0	0	-126	-160	\$2,594	2434	1716	5595	18737	
2019	0	0	0	0	-126	-166	\$2,594	2428	1615	7210	18737	
2020	0	0	0	0	-126	-173	\$2,594	2421	1519	8729	18737	
2021	0	0	0	0	-126	-180	\$2,594	2415	1429	10158	18737	
2022	0	742	302	1701	0	0	\$2,829	2829	1580	11738	20438	

**Present worth spreadsheet for Option 2(b)**

		Present Worth Years	Cumulative Present Worth	Cumulative Investment	Annual Cost						
		41	27907	19658	1843						
The following rates will be assessed in the analysis:											
Investment: Capital Recovery:		Dist: 7.50%	Lines: 7.50%	Subs: 7.50%	Interest Rate: 6.00%			Year of study: 2012			
Property Tax:		3.50%	3.50%	3.50%	Investment Esc.: 5.00%			Year of dollar: 2012			
O&M:		2.00%	2.00%	2.00%	Expense Esc.: 4.00%						
G&A:		0.80%	0.80%	0.80%							
Insurance:		0.10%	0.00%	0.10%	Losses (\$/kW/yr.):	\$ 315.65					
Charge Rate:		13.90%	13.80%	13.90%			Costs are in: 1000's				
Year	Dist. Invest. 2012 Dollars	Lines Invest. 2012 Dollars	Subs. Invest. 2012 Dollars	Escalated New Invest.	Expenses 2012 Dollars	Escalated Expenses	Investment Revenue Requirement	Revenue Require.	Present Worth of Revenue Requirement	Cumulative PW 2012 Dollars	Cumulative Investment
2012	0	0	0	0	0	0	\$0	0	0	0	0
2013	0	0	0	0	0	0	\$0	0	0	0	0
2014	0	0	0	0	0	0	\$0	0	0	0	0
2015	0	0	0	0	0	0	\$0	0	0	0	0
2016	0	6572	2343	10837	0	0	\$1,498	1498	1187	1187	10837
2017	0	0	0	0	0	0	\$1,498	1498	1120	2306	10837
2018	0	0	0	0	0	0	\$1,498	1498	1056	3363	10837
2019	0	0	0	0	0	0	\$1,498	1498	996	4359	10837
2020	0	0	0	0	0	0	\$1,498	1498	940	5299	10837
2021	0	0	0	0	0	0	\$1,498	1498	887	6186	10837
2022	490	1028	3898	8821	0	0	\$2,723	2723	1520	7706	19658

# Appendix H: System One-line Diagrams

## Existing System Analysis using the 2012 SUPK model

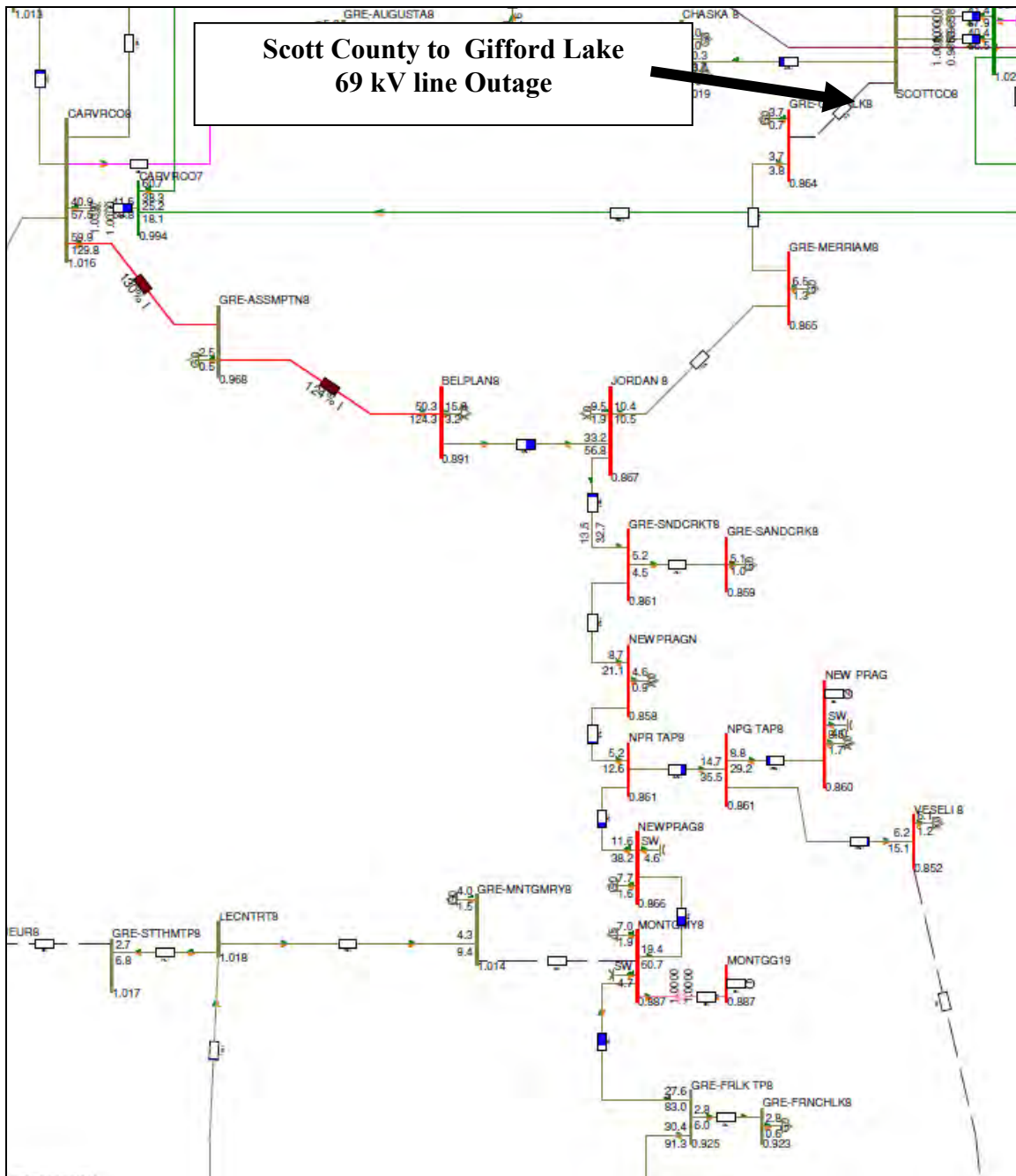
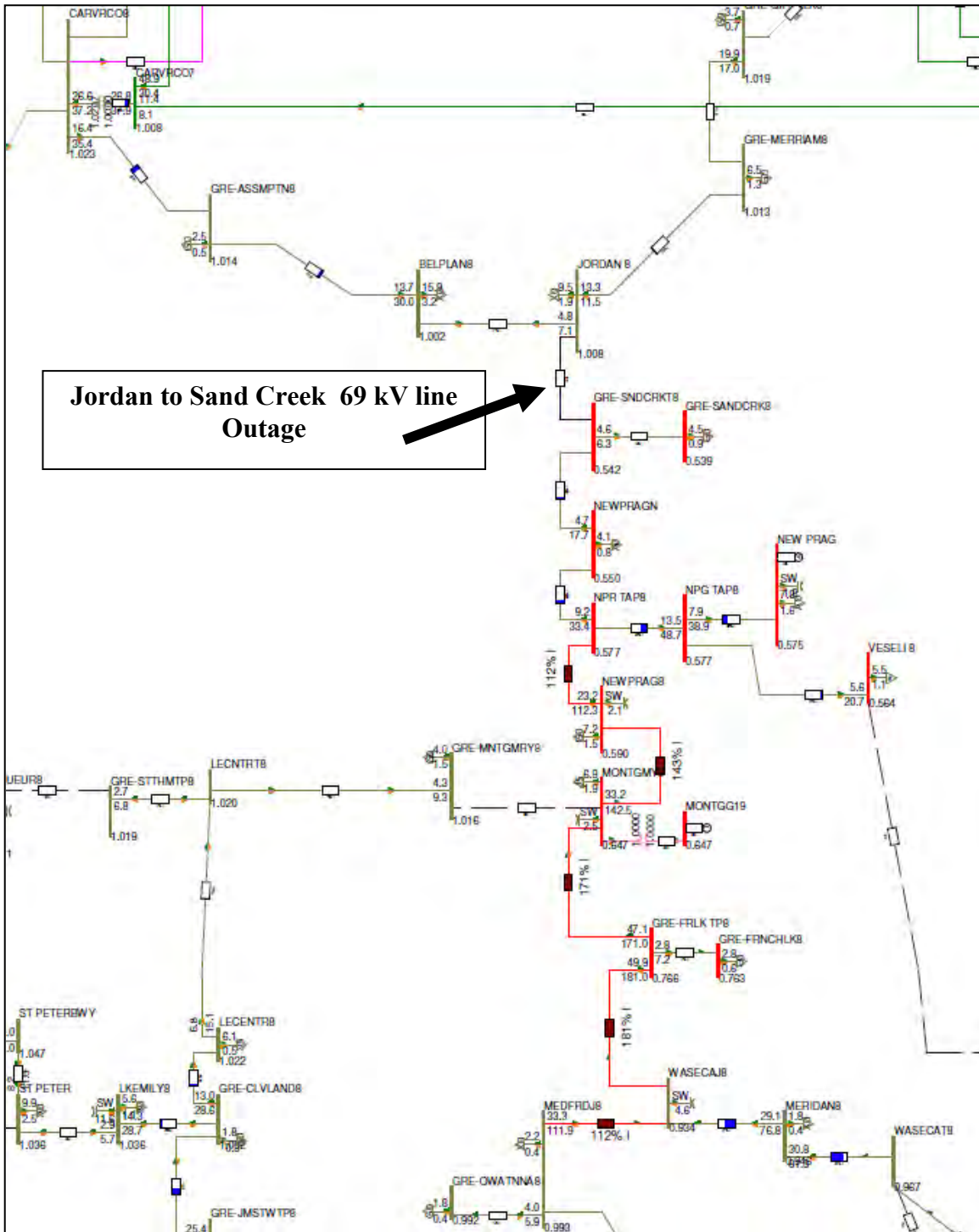

Figure H-1: Scott County – Gifford Lake 69 kV line Outage



**Figure H-2: Jordan to Sand Creek 69 kV line Outage**

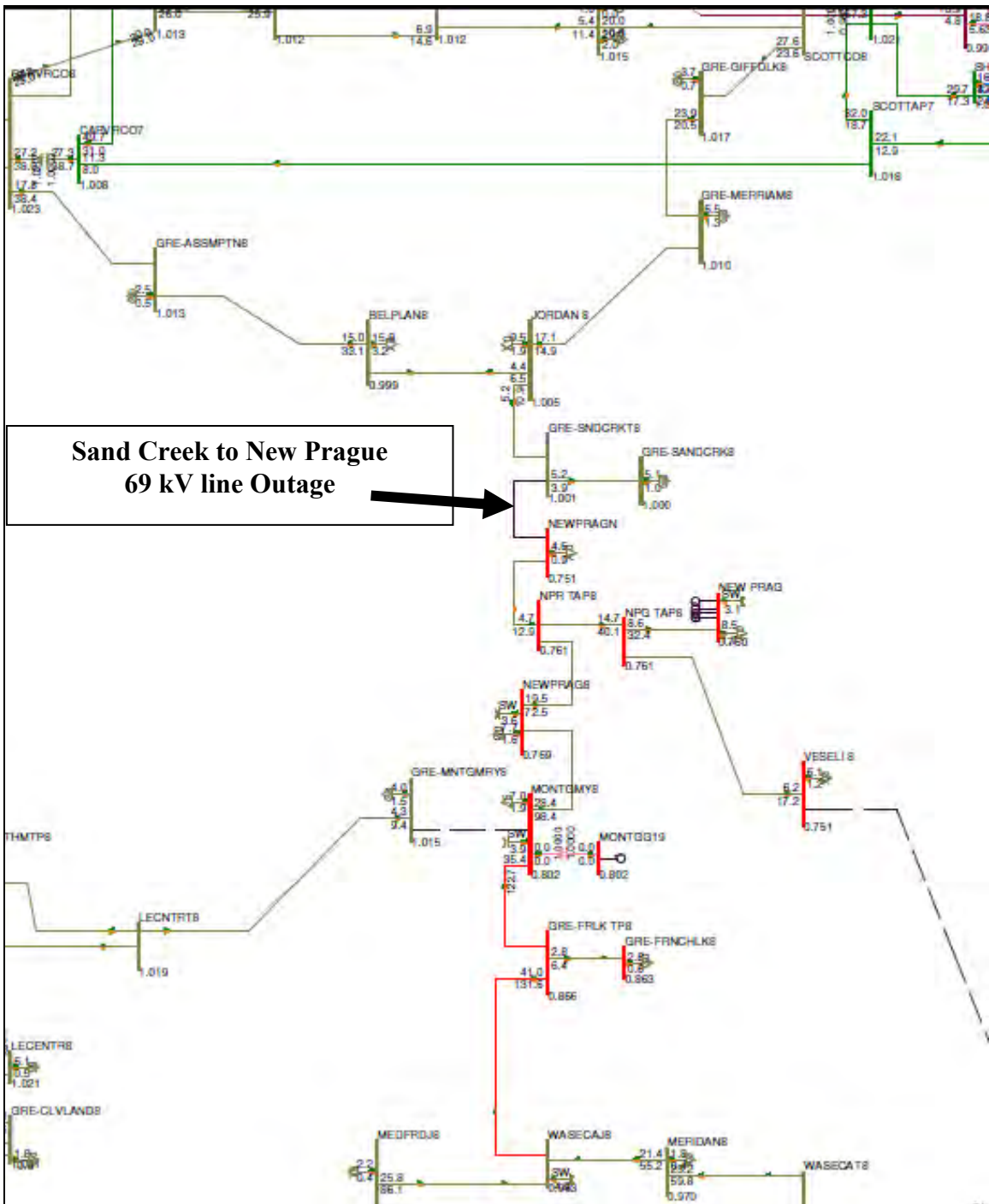
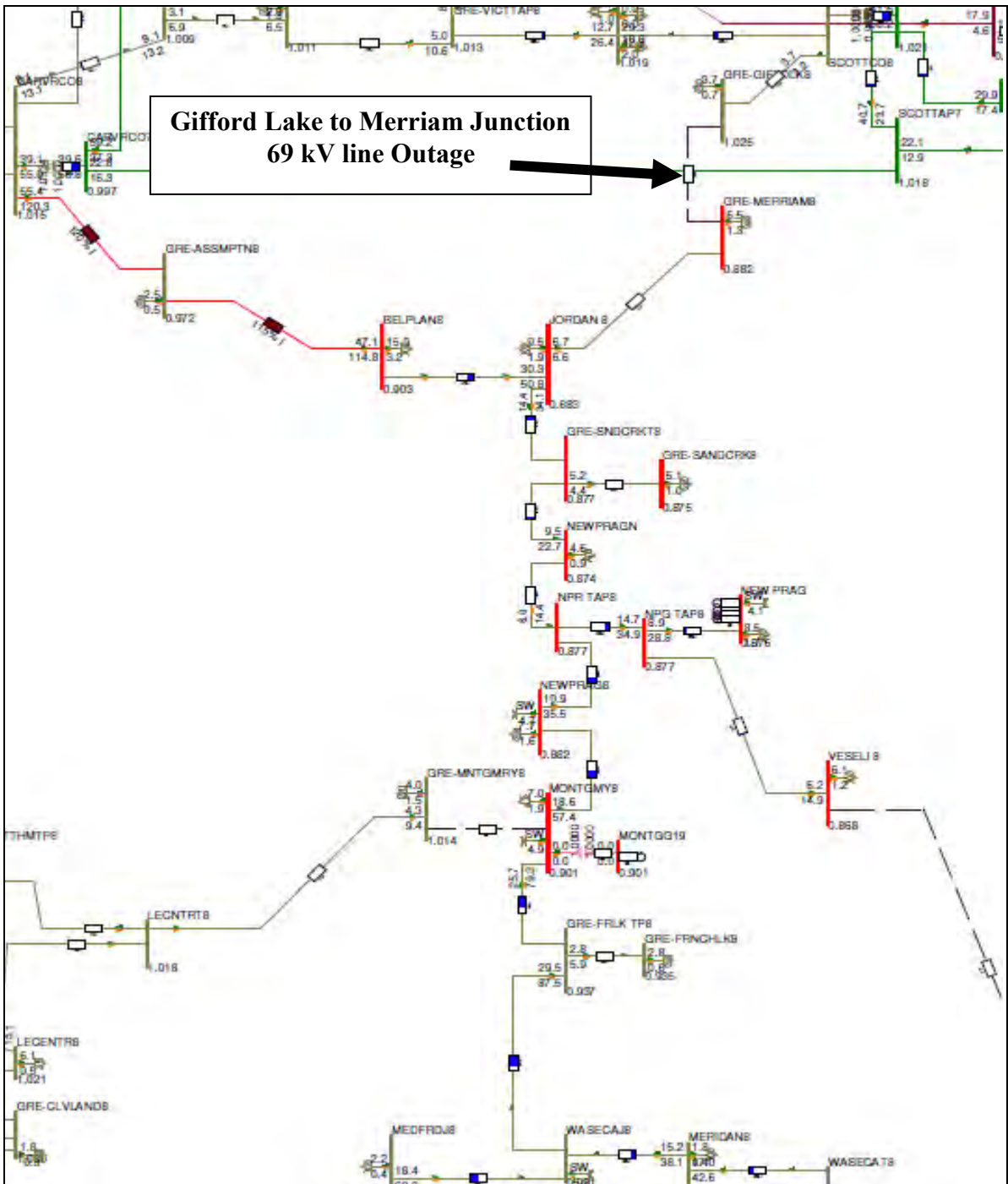
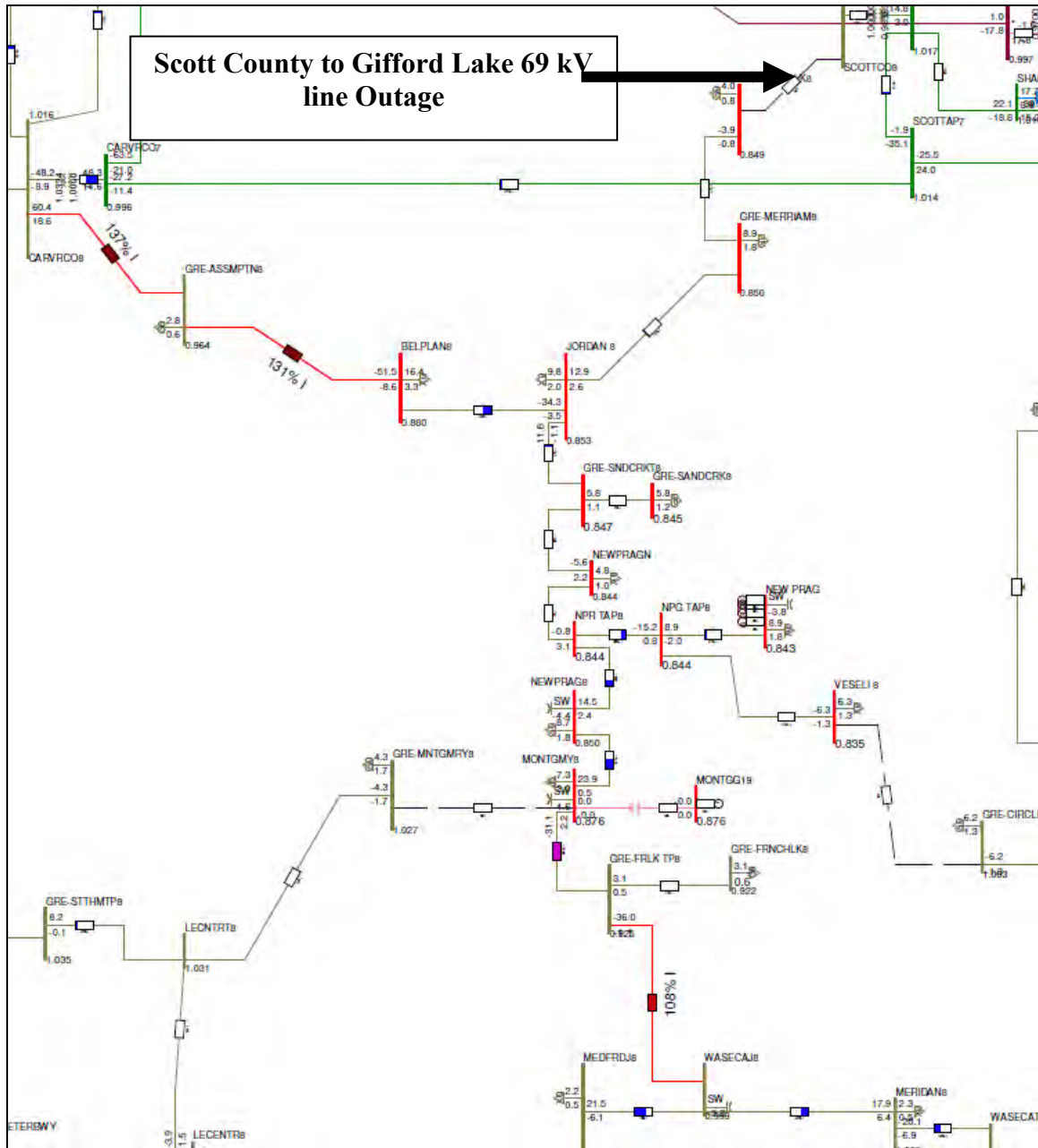

Figure H-3: Sand Creek to New Prague 69 kV line Outage



**Figure H-4: Gifford Lake to Merriam Junction 69 kV line Outage**

**Out-year Analysis using the 2016 SUPK model**



**Figure H-5: Scott County – Gifford Lake 69 kV line Outage**



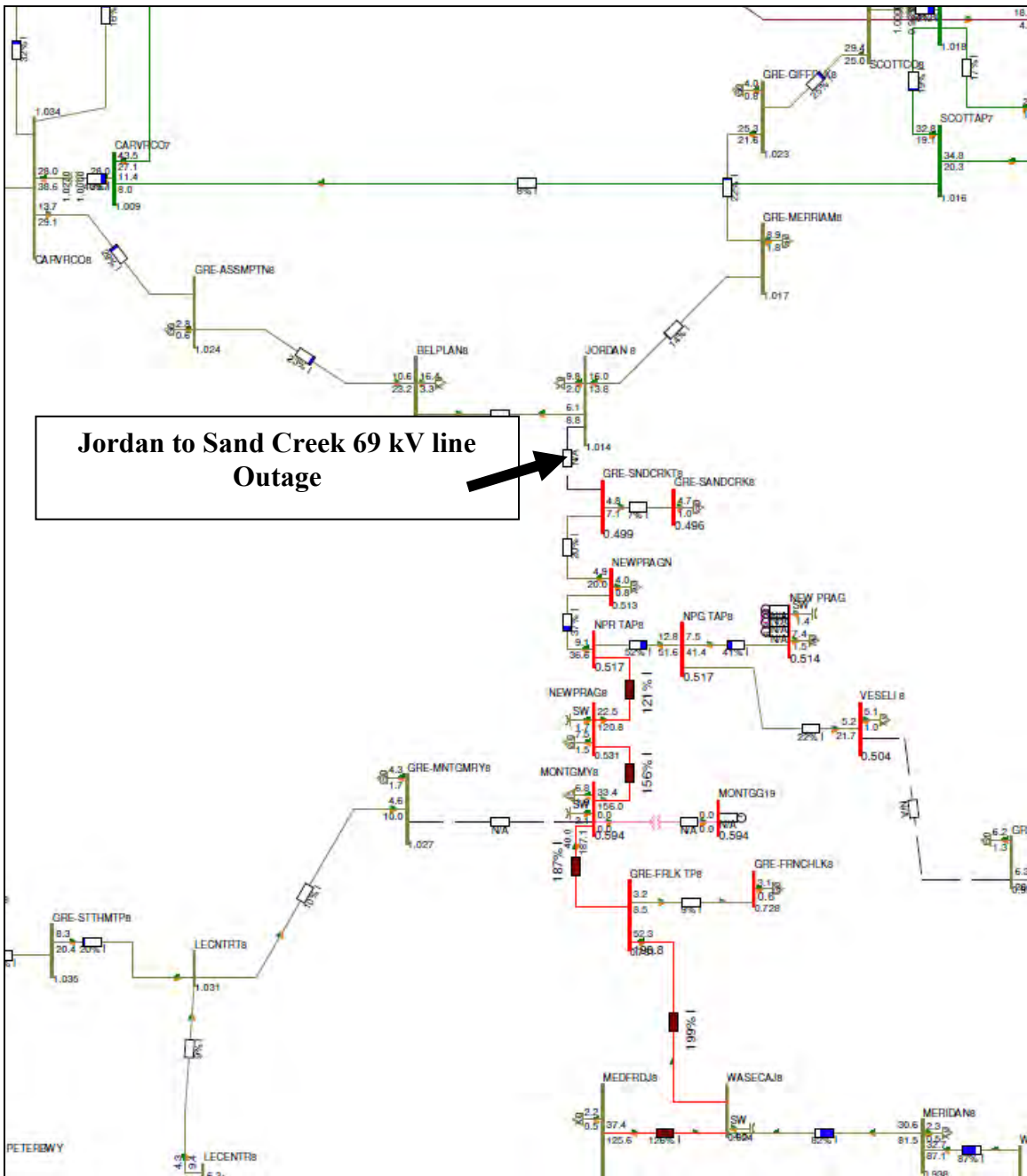
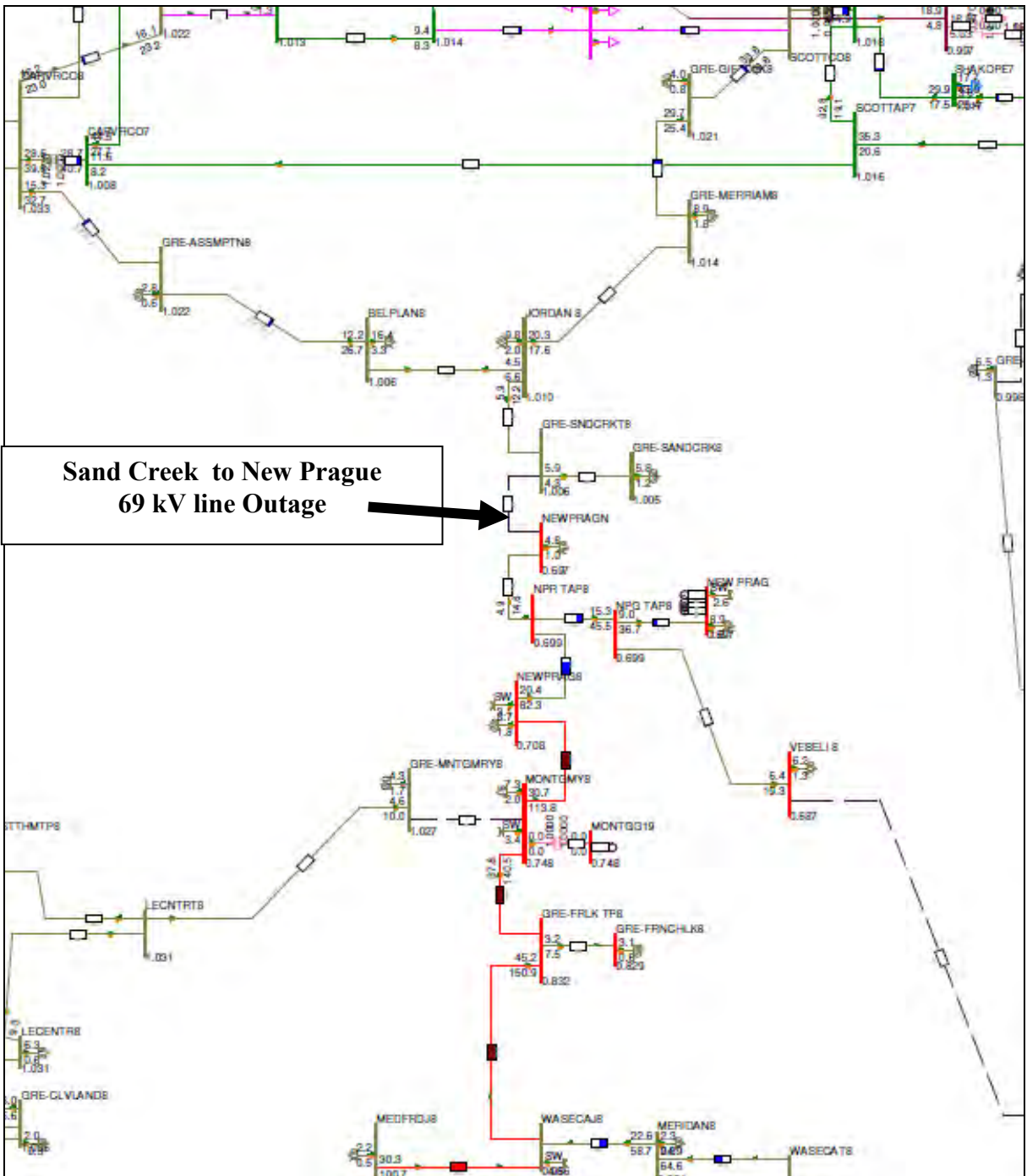

Figure H-6: Scott County – Gifford Lake 69 kV line Outage



**Figure H-7: Sand Creek Tap to New Prague 69 kV line Outage**

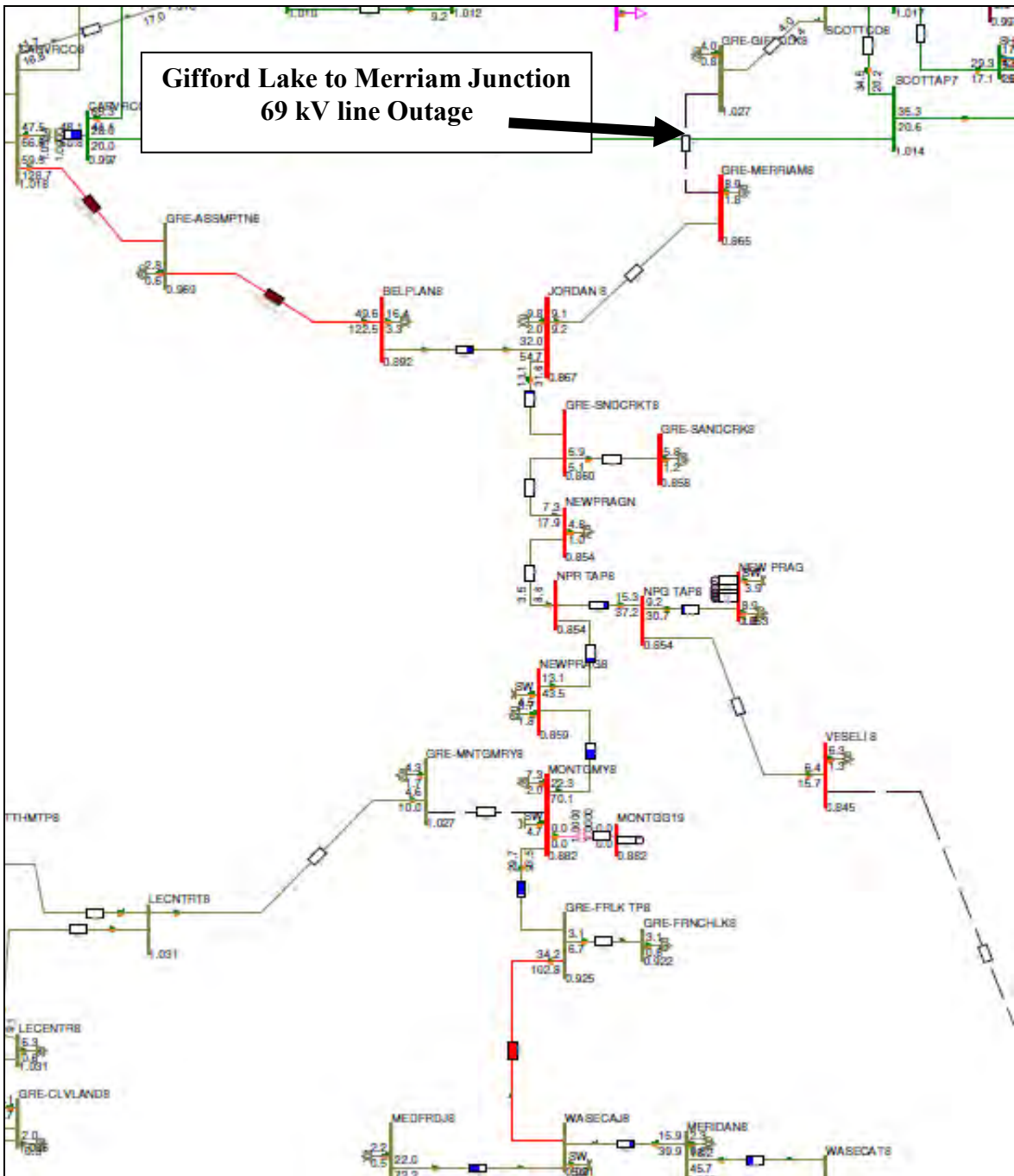
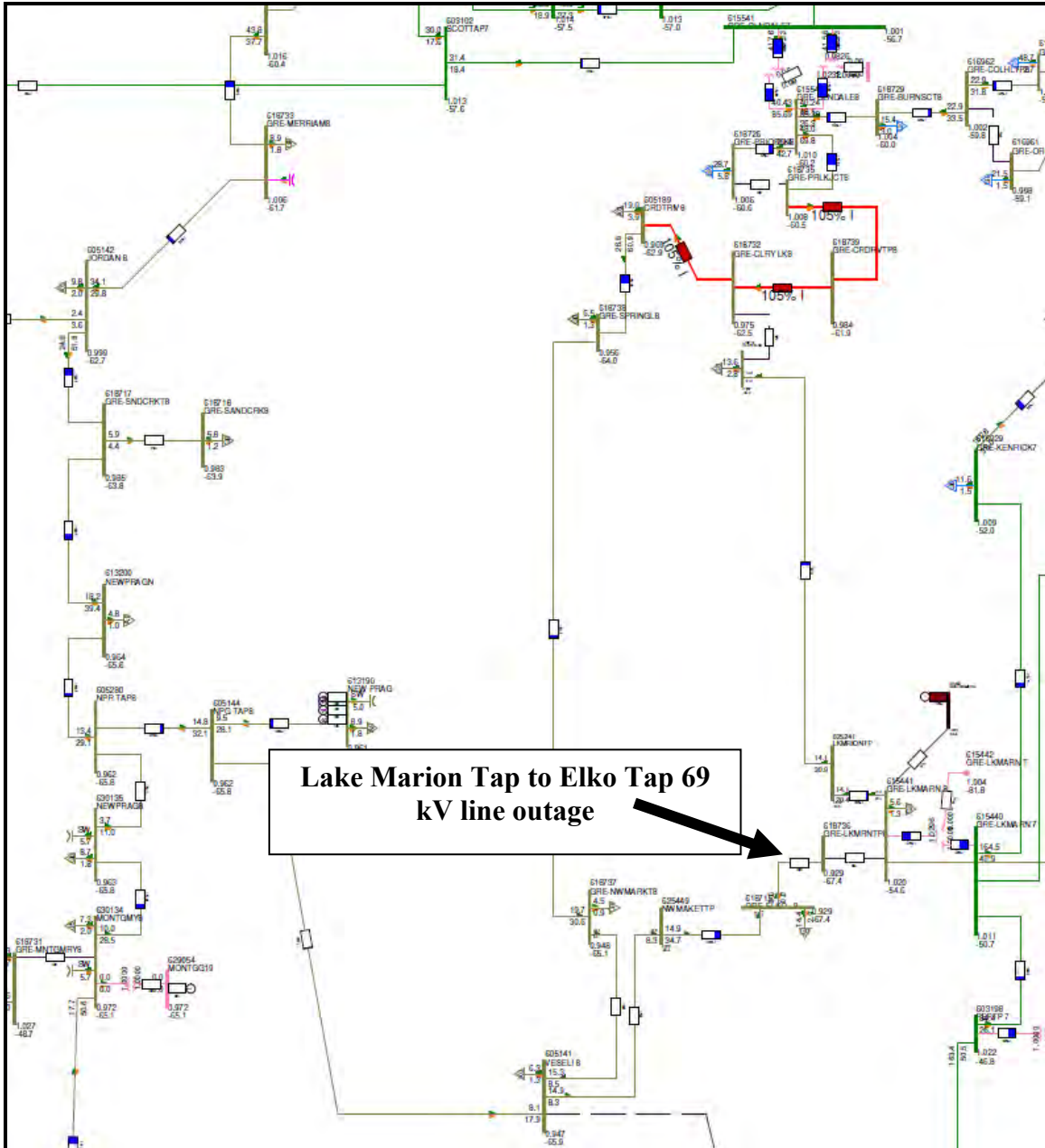
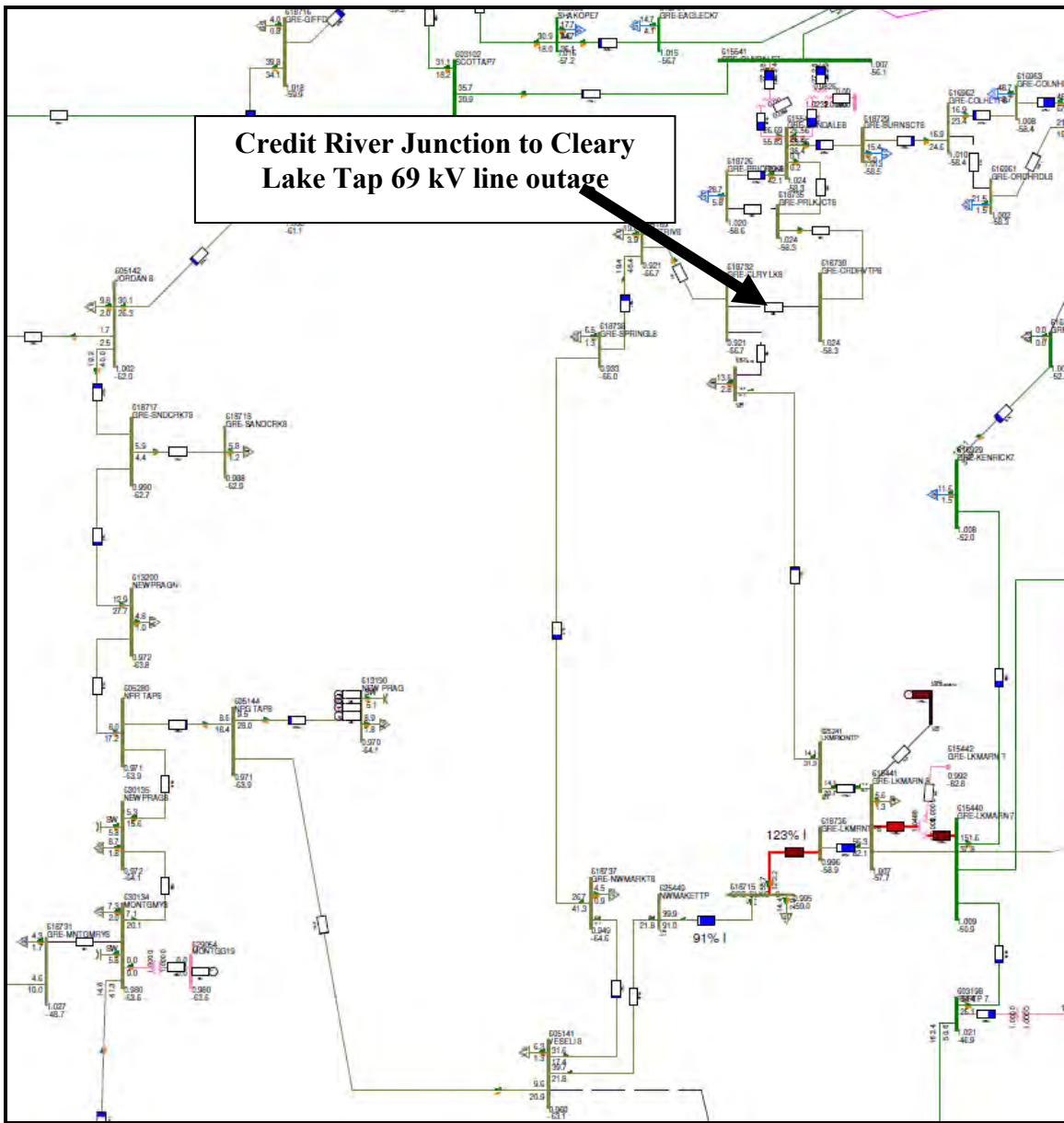

Figure H-8: Gifford Lake to Merriam Junction 69 kV line Outage

The following two online diagrams, Figure H-9 and Figure H10, are included to illustrate that the existing 4/0A overload during contingencies with the addition of the New Market to Veseli double circuit line addition. The level of overload on these transmission lines would have been significantly higher without the reconfiguration of service to the Cleary Lake substation.



**Figure H-9:** New Market Tap – Elko 69 kV line outage



**Figure H-10:** Credit River Junction to Cleary Lake Tap 69 kV line outage

**THIS PAGE INTENTIONALLY BLANK**

# **APPENDIX I**

## **Great River Energy Demand Side Management Programs**

**THIS PAGE INTENTIONALLY BLANK**



## **GREAT RIVER ENERGY DEMAND SIDE MANAGEMENT PROGRAMS**

### **A. The name of the committee, department, or individual responsible for the applicants energy conservation and efficiency programs, including load management;**

Great River Energy's Member Services Division is responsible for energy conservation and load management programs.

### **B. A list of the applicant's energy conservation and efficiency goals and objectives;**

- Per Minnesota Statute 216B.241, Subd. 1c. Great River Energy's 2012 energy conservation goal for its member cooperatives is equal to 169,012,726 kWh at the generator. This figure represents 1.5% of GRE's members average weather normalized sales for 2008-2010, less sales to customers that have received formal CIP exemptions from the Minnesota Department of Commerce. The Minnesota Department of Commerce, Division of Energy Resources has approved GRE's 2012 program plan, which includes a broad array of programs that cover the residential, commercial, industrial and agricultural sectors.
- Per Great River Energy's load management programs, the goal is to maximize the value of current load management programs by identifying new revenue streams available in a FERC approved ISO market. Opportunities include load management as market energy, regulation and/or reserves.

### **A description of the specific energy conservation and efficiency programs that the applicant has considered, a list of those that have been implemented and the reasons why the other programs have not been implemented;**

Each year, Great River Energy conducts feasibility studies on potential programs. Programs with verifiable energy reductions and no market barriers that are found to be cost effective are implemented. Programs that are difficult to quantify with market barriers, or are not cost effective are not added to the program portfolio.

A brief description of each program, by program type, that allows Great River Energy to achieve its strategic conservation and load management goals is provided below.

## **INDIRECT CONSERVATION PROGRAMS**

### Energy Education

Member cooperatives assist residential and commercial/industrial customers to help make them aware of the available energy conservation and energy efficiency programs through brochures, bill inserts, radio advertisements, newsletters, workshops, fairs, trade shows, and one-on-one consultation.

### Residential Electrical Evaluation and Consultation

The residential electrical evaluation and consultation program is targeted at customers who contact their member cooperative and express concern over their electrical usage. When a customer contacts their cooperative representative, the representative reviews general appliance

usage and costs with the customer. The review provides an overview of the customer's energy usage and provides suggestions on various means by which the customer can conserve energy.

## **DIRECT CONSERVATION PROGRAMS - RESIDENTIAL**

### Energy Assessments/Audits

Members offer free or reduced cost energy audits for residential and commercial customers. Cooperatives have staff specifically trained to conduct basic audits. In addition to the basic audits, participating members work with local Community Action Programs (CAP) agencies to target low-income households that could benefit from energy conservation education.

Commercial consumers are provided with either a walk-through energy audit performed by cooperative staff or a more comprehensive audit performed by a professional consultant. Costs for the comprehensive audit are typically shared 50 percent by Great River Energy, through the distribution cooperative, and 50 percent by the customer.

### Residential Cooling

Residential air conditioning is a critical load to Great River Energy and its member distribution cooperatives. High-efficiency air conditioners improve system load factor, reduce peak capacity requirements, improve system efficiencies, and lower customer's cooling costs. Great River Energy, through its member cooperatives, provides a rebate for central air conditioners that have a Seasonal Energy Efficiency Ratio (SEER) of 13 or greater. This increased efficiency results in energy and demand savings during Great River Energy's critical summer period.

### Residential Air Source Heat Pump (ASHP)

ASHPs provide summer cooling and spring/fall heating in residential or commercial installations. ASHPs are sized for cooling. In the cooling mode, the ASHP functions as a central air conditioner and is load managed during the summer per Great River Energy's cycled air conditioning control strategy. In the heating mode, the ASHP provides very efficient space heating to a temperature of approximately 20 degrees F. At this temperature the ASHP automatically shuts off and the secondary heating system (typically a natural gas or liquid propane furnace) heats the home. If conditions should require load control, Great River Energy also has the ability to control ASHPs during the heating season. ASHPs help Great River Energy improve load factor, reduce peak capacity requirements, and improve system efficiencies.

### Quality Installation Program for Central Air Conditioners and Air Source Heat Pumps

In addition to offering equipment rebates, GRE and its member cooperatives provide additional incentives for quality installation of high-efficient central air conditioners and air-source heat pumps. In order to generate maximum electric energy savings, it is essential that the equipment is installed correctly and according to manufacturer's specifications. The quality installation program seeks to validate four components of the installation:

- 1) Air flow
- 2) Duct Sealing
- 3) Proper sizing
- 4) Refrigerant charge

New central air conditioners and air source heat pumps with an overall efficiency of 13 SEER or higher are eligible. The system must be matched, which means the outdoor condenser unit and the indoor evaporator coil are designed by the manufacturer to work together to provide top performance and maximum efficiency.

#### Residential HVAC Tune-Up

Rebates are available to members who hire a registered and/or professional Heating Ventilation and Air Conditioning (HVAC) contractor to perform a tune-up of an existing, working Cycled Air Conditioner (CAC) or ASHP. This program is designed to improve the efficiency and maintain the operation of CACs and ASHPs.

#### Residential Cycled Air Conditioning and ASHP

The cycled air conditioning program provides customers with an incentive to allow Great River Energy to cycle (15 minutes on, 15 minutes off) their central air conditioner during periods of high peak demand. The cycling provides approximately one kilowatt (kW) of demand reduction per air conditioner. Air conditioning is a critical load to the member distribution cooperatives and to Great River Energy. The program helps improve system load factor, reduce peak capacity requirements, and improve system efficiencies.

#### Residential Geothermal

Ground Source Heat Pumps (GSHPs) have proven to be one of the most efficient space conditioning options with the added potential of significant energy savings. Acceptance of this technology continues to grow nationwide. GSHPs use the latent heat in the earth as a heat sink and a heat source. By utilizing a series of buried heavy-duty plastic pipes filled with a food-grade antifreeze solution as the heat transfer medium, GSHPs are highly efficient in both heating and cooling modes. This high efficiency results in reduced kWh usage in the cooling season and can also significantly reduce the total energy used to heat a home when compared to alternative heating systems. Along with the kilowatt hour (kWh) savings, there is capacity savings when the GSHP is part of the load management program.

#### Income Eligible: AC Tune-UP

Participating member distribution cooperatives offer air conditioning tune-ups to low-income customers in conjunction with local CAP agencies. The role of a CAP agency is to help identify customers that would benefit from this service and to provide instruction to local HVAC service vendors authorized under this program to provide tune-ups. The tune-up service includes:

- Cleaning condenser coil
- Checking Freon level and pressures
- Checking indoor filter
- Testing all controls
- Blowing out drain line
- Visually inspecting the entire system
- Educating homeowner on operation

The low-income air conditioner tune-up program improves air conditioner efficiency, which in turn lowers the customer's energy bill.

### Income Eligible

Participating member distribution cooperatives provide renters or rental property owners with help to improve the energy efficiency of the property. Programs include high efficiency space heating and cooling, lighting retrofit, appliance replacement, energy saving water kits, Habitat for Humanity, and air conditioner tune-ups.

### Residential Lighting

Lighting makes up ten percent of a typical home's electricity consumption. The home lighting program is an energy conservation program in the form of a rebate that encourages the conversion from incandescent lighting to more energy efficient lighting – particularly compact fluorescent lighting (CFLs) and light emitting diodes (LEDs). Promotions are also offered throughout the year at major retailers for instant in-store savings (Wal-Mart and Target).

### Bulb Recycling

This program is designed to support Minn. Stat. §115A.932 to encourage residential members to properly recycle CFLs. Great River Energy offers \$0.50 per lamp rebate through local retailers. Free recycling was available in 2008-2009 through participating Menards stores.

### High Efficiency Water Heat

Customers replacing old inefficient electric water heaters with new high efficiency electric water heaters receive a cash rebate from a participating distribution cooperative. The minimum acceptable water heater has insulation of R16 or greater, and an energy efficiency factor of 0.92. The average water heater replaced has an efficiency factor of 0.82 or less.

### Residential Dual Fuel and Pool Heat

Dual fuel space heating is a heating option for the conditioned living space in residential customers' homes that use only electric heat as the primary heat source. Cooperative members must have a backup heat source (propane or fuel oil) to provide heat to the entire living area or pool. Member incentives may include all or a portion of the costs to install load controls on equipment.

### Hot Water Savings

This program offers an opportunity for residential members to purchase and install a variety of energy saving water equipment at a significantly reduced price. The kit includes shower head, kitchen aerator, bathroom aerators, hot water temperature card, and teflon tape to assist with the installation. Kits are provided at no cost to income-eligible members and CAP agencies for installation in income-eligible properties.

### Electric Vehicle and ChargeWise<sup>SM</sup>

Great River Energy provides a specific rate for charging on and off-road electric vehicles such as Plug-in Hybrid Electric Vehicles (PHEV), golf carts, forklifts, etc., which can operate "around-the-clock" from a nightly eight hour charge. Great River Energy will rebate up to \$500 of the installation cost for the ChargeWise<sup>SM</sup> kit. The ChargeWise<sup>SM</sup> program requires the program participant be a residential customer of an all requirements member.

## **DIRECT CONSERVATION PROGRAMS – COMMERCIAL, INDUSTRIAL, and AGRICULTURE (CI&A)**

### Agriculture

Agricultural prescriptive and custom rebates are available to members for the installation of various types of high efficiency agricultural equipment. Rebates are offered for the following applications:

- Ventilation
- Dairy-Free Heater
- Dairy Plate Cooler
- Hog Farrowing
- Compressor Heat Recovery Systems
- Scroll Compressors for Bulk Tank
- Low Pressure Irrigation Systems
- Livestock Water Heaters

### Compressed Air

This program rebates members for installing compressed air systems, equipment updates or system improvements that result in lower energy usage.

### Custom

The CI&A energy grant and rebate program provides cash incentives to qualified applicants for energy efficiency improvements to their business, industry, or farm. Interested customers must complete a grant application form, which describes the intended energy efficiency improvement measures and calculates the expected energy and demand savings. The individual member cooperative evaluates the proposal for viability and cost effectiveness, and those that rank the highest are awarded grants to help offset the cost of their project. Grant funds are typically used for the installation of high efficiency lighting, motors, adjustable speed drives, refrigeration compressors, high efficiency air conditioning, and other energy-conserving equipment. The program also includes a New Construction Rebate for Lighting and Motors. This rebate is on a per fixture basis or on the horsepower rating of the motor.

### Energy Assessments/Audits

Members offer free or reduced cost energy audits for residential and commercial customers. Cooperatives have staff specifically trained to conduct basic audits. In addition to the basic audits, participating members work with local CAP agencies to target low-income households that could benefit from energy conservation education.

Commercial consumers are provided with either a walk-through energy audit performed by cooperative staff or a more comprehensive audit performed by a professional consultant. Costs for the comprehensive audit are typically shared 50 percent by Great River Energy, through the distribution cooperative, and 50 percent by the customer.

## **COMMERCIAL HEATING VENTILATION AND AIR CONDITIONING (HVAC)**

Program rebates are offered to members for qualifying commercial cooling equipment installation. Only new and complete central air conditioning units and remote condensing unit retrofits qualify.

### Commercial GSHPs

GSHPs have proven to be one of the most efficient space conditioning options with the added potential of significant energy savings. This high efficiency results in the reduction of kWh usage in the cooling season and can also significantly reduce the total energy used to heat a building when compared to alternative heating systems. A number of building types are able to take advantage of the benefits of heating and cooling with GSHPs and the program targets schools, churches, and other commercial and industrial buildings where appropriate.

### Commercial New Construction Lighting

Prescriptive and custom rebates are available for lighting projects in retrofit, new construction and LED traffic signal retrofit applications. Specific dollar amounts, per fixture, vary based on the type of luminaries installed, lamp wattage, length and number of lamps per fixture.

### Commercial Retrofit Lighting

Rebates are offered for retrofit lighting projects in existing structures. They are determined individually, based on equipment being removed and replaced with more efficient lighting or controls. For projects not covered by the prescriptive rebate application form, a custom rebate will calculate the energy savings and determine the rebate amount.

### Commercial Motors and Drives

This program offers rebates for new or existing retail businesses. Rebates are determined on an individual basis using the prescriptive rebate forms for the motors and drives being installed. Motors that meet the National Electrical Manufacturers Association (NEMA) Premium Efficiency Motor Standards for retrofit applications are eligible.

### Commercial Whole Building Energy Efficiency

Member cooperatives provide energy efficient educational materials and speakers for little or no cost to members at community meetings, key account meetings and other public informational gatherings. Member cooperatives also offer design assistance, building commissioning, building recommissioning, and audits that are specific for the commercial, industrial, or agricultural members needs.

### Vending Controls

Rebates are available for control devices that are either occupancy or moisture sensor-based installed on beverage vending machines, glass-front beverage machine coolers or glass-front refrigerated display case doors.

## **DIRECT LOAD CONTROL PROGRAMS**

### Interruptible CI&A Loads

The Interruptible CI&A Loads Program provides a reduced electric rate to CI&A customers that can reduce their demand by a minimum of 25 kW during periods of high demand.

### Interruptible Air Conditioning

The interruptible air conditioning program is available to residential, commercial, and industrial members annually from May through September. During these months members agree to have their air conditioning systems interrupted for up to six (6) hours on event days.

### Interruptible Irrigation

Interruptible commercial irrigation systems, generally agricultural, turf growers, or golf courses, can be interrupted once per day for up to four hours.

### Dual Fuel Space Heating

Dual fuel space heating systems are a combination of interruptible electric and non-electric space heating. Both the primary and secondary heating systems are sized for the entire heating load of the home. During periods of high electric demand, the interruptible electric heating system is shut off and the secondary (non-electric) heating system heats the home.

### Electric Thermal Storage (ETS) Space Heating

The ETS space heating program uses off-peak electric energy to provide 100% of a home's heating requirements. During the nightly eight-hour ETS charge time, heat is stored in a water or ceramic medium. There are three commonly available storage heating configurations: central furnaces, room or dispersed heaters, and slab. Customers receive a special off-peak rate in return for allowing Great River Energy to control their systems each day during the on-peak hours.

### Electric Thermal Storage (ETS) Water Heating

The ETS water heating program uses off-peak electric energy coupled with a high efficient water heater with sufficient storage capacity to supply the user's hot water needs. The water heaters are charged between 11:00 pm and 7:00 am each evening.

### Interruptible Water Heating

Interruptible water heaters can be interrupted during periods of high electric demand for up to eight hours per day. Customers receive a special interruptible rate in return for allowing Great River Energy to control their water heaters during peak periods.

### Electric Thermal Storage (ETS) Pool Heating

The ETS pool heating program uses off-peak electric energy to heat water for swimming pools. Swimming pools can be sufficiently heated during the nightly eight-hour off-peak charge time. Member distribution cooperatives provide participants a reduced electric rate for the ability to interrupt this load during the on-peak hours.

### Off Peak Electric Vehicles and "ChargeWise<sup>SM</sup>"

The Electric Vehicle and "ChargeWise<sup>SM</sup>" program charges electric vehicle batteries using only off-peak energy between 11:00 pm and 7:00 am nightly. Examples of qualifying vehicles are electric forklifts, golf carts, and residential PHEVs and EVs.

## **WELLSPRING RENEWABLE ENERGY PROGRAM**

The Wellspring renewable wind energy program is a voluntary “green pricing” program that offers wind-generated electricity to cooperative members. Great River Energy was the first utility in the five-state region to offer such a program. Green pricing is a voluntary service that allows members the opportunity to purchase 100 kWh blocks of renewable energy and pay a premium on their electric bill to cover the incremental cost.

## **EVALUATED PROGRAMS**

### Pool Pump

The Pool Pump program is currently available on a pilot basis. The program is available to members that have an in-ground swimming pool. Members replacing an old inefficient pump with a new high efficiency pump can receive a rebate from their participating distribution cooperative.

### PC Power Management

Connexus Energy, Dakota Electric, and Minnesota Valley Electric Cooperative are currently evaluating PC Power Management based on the “Electricity Savings Opportunities for Home Electronics and Other Plug-In Devices in Minnesota Homes”. The report was completed in 2010 by the Energy Center of Wisconsin. The program allows a member to download an internet application that manages the energy used by a home PC based on an energy use profile that automatically switches the computer to a hibernate mode when it is not used for a predetermined length of time.

### Data Centers

Data center rebates are not a specific program, rather they are covered under the custom grant program or by individual measures done at the site (HVAC, Lighting, Controls, etc.)

### Battery Energy Storage

The intent of the program was to store off-peak energy in lead acid batteries to be discharged during the on-peak hours. Great River Energy’s analysis showed that the cost of the units and the kWh capacity was not able to yield a positive return on investment, via energy arbitrage, over the life of the unit.

### Ice Energy Storage

The potential to store off-peak energy in large insulated vessels to be discharged during on-peak hours was investigated. The units are deployed in conjunction with existing commercially packaged HVAC rooftop units. When the HVAC unit calls for cooling, a pump circulates coolant through coils in the ice and transfers the cold fluid to a separate condenser installed in the HVAC unit. The program was not found to be cost effective.



**C. A description of the major accomplishments that have been made by the applicant with respect to energy conservation and efficiency;**

**Conservation and Efficiency**

Great River Energy has met the CIP goals outlined not only in 2010 when the legislation took effect, but also the goals established internally for 2008 and 2009. Additional information on the success of the conservation and load management programs is provided in the tables on the following pages.

**2008:** 78,000,000 kWhs saved (0.7% of member sales)

**2009:** 94,000,000 kWhs saved (0.85% of member sales)

**2010 All Requirements Members\*:** 117,226,945 kWh saved at the generator equaling 1.34% of member sales.

**2011 All Requirements Members:** 110,152,388 kWh saved at the generator equaling 1.27% of member sales.

**2012 All Requirements Members (preliminary):** 83,744,605 kWh saved at the generator equaling 1.0% of member sales.

*\* Twenty (20) all-requirements members purchase all of the power and energy needed to satisfy their electricity sales from Great River Energy, with limited exceptions for amounts historically supplied by the Western Area Power Administration ("WAPA") or from renewable generation facilities directly interconnected at a distribution level. Great River Energy has the responsibility and obligation to plan for and supply all of the future power and energy needs of the all-requirements member rate class.*

*Eight (8) fixed members purchase a finite contractual amount of power and energy from Great River Energy that does not change based on their current actual use or need. As such, the energy conservation savings achieved by the fixed members does not reduce Great River Energy's power supply obligations or impact its need for future generation resources. Some fixed members purchase power and energy historically supplied by WAPA or from renewable generation facilities directly interconnected at the distribution level. The fixed members have made arrangements for other wholesale suppliers to assume responsibility and obligation to plan for and supply all of their future power and energy needs.*

*Total kWh saved do not include kWh savings generated through supply side investments. In 2010 GRE and its member cooperatives realized an additional 66,699,755 kWh in savings associated with improvements to generation and cooperatives distribution assets.*

*Generator kWh savings add 11.5% to the energy savings that are realized at the end use member. This amount is an average reflecting the line-losses that occur through the Transmission and Distribution of electricity to end use members.*

**CIP Savings and Expenditures – All Requirements Members Only  
Great River Energy  
2008-2012**

<b>CIP Year</b>	<b>Annual kWh</b>	<b>Lifetime kWh (based on average measure lifetime)</b>	<b>Annual KW</b>	<b>Aggregate KW (based on measure of lifetime)</b>	<b>Annual CIP Spending</b>	<b>Aggregate CIP Spending</b>
<b>2008</b>	70,432,275	880,403,438	125,825	125,825	\$16,248,830	\$16,248,830
<b>2009</b>	79,467,727	998,114,651	77,418	203,243	\$18,759,091	\$35,007,921
<b>2010</b>	117,226,945	1,441,891,424	41,634	244,877	\$20,598,092	\$55,606,013
<b>2011</b>	110,152,388	1,371,764,400	35,400	280,277	\$18,306,921	\$73,912,934
<b>2012</b>	83,744,605	1,042,899,483	20,189	300,466	<i>Pending</i>	<i>Pending</i>
<b>Total</b>	<b>461,023,940</b>	<b>5,735,073,396</b>	<b>300,466</b>	<b>300,466</b>	<b>\$73,912,935*</b>	<b>\$73,912,935*</b>

\*Total amounts do not include spending for 2012; GRE and its all-requirement member cooperatives spent approximately \$6,000,000 on participant incentives in 2012. All additional costs associated with the delivery, administration, evaluation, and advertising and promotion of these programs is being collected. Historically these costs have represented more than 100% of the costs associated with participant incentives. Total kWh saved does not include kWh savings generated through supply side investments. In 2010 GRE and its member cooperatives realized an additional 66,699,755 kWh in savings associated with improvements to generation and cooperatives distribution asset

## Demand Side Management

<b>Additional Controlled Load Great River Energy 2010-2012</b>			
<b>Additional Controlled Load Installed by Customer Class (kW)</b>			
	<b>2010</b>	<b>2011</b>	<b>2012</b>
<b>Residential</b>	9,500	9,000	8,700
<b>Commercial</b>	12,000	1,000	6,000
<b>Total*</b>	<b>21,500</b>	<b>10,000</b>	<b>14,700</b>
<b>Total Controlled Load Installed by Load Type (MW)</b>			
	<b>2010</b>	<b>2011</b>	<b>2012</b>
<b>Dual Fuel</b>	135	137	140
<b>Cycled Air Conditioning</b>	100	104	106
<b>Interruptible Water Heating</b>	36	38	39
<b>Irrigation</b>	30	31	31
<b>Interruptible C&amp;I</b>	158	165	170
<b>Total MW</b>	<b>459</b>	<b>475</b>	<b>486</b>

\* The effect of energy conservation and load management programs on load is implicit in Great River Energy's forecasts. The forecast is calculated using raw load data, and does not make any adjustments that attempt to measure the impact of energy efficiency or load management activities. DSM and conservation programs do have a significant effect in reducing the need for new resource additions. In aggregate, Great River Energy's load management programs are capable of reducing summer and winter peak loads by 15%.

### **D. A description of the applicant's future plans through the forecast years with respect to energy conservation and efficiency.**

Great River Energy and its Members have developed a robust portfolio of energy efficiency programs that provide measureable value for member-consumers in Minnesota. These programs are a dynamic and active part of Great River Energy's planning and daily operations and provide member-consumers with options for managing their energy use and associated costs.

The key to maintaining success hinges on the ability to promote current programs while developing new programs that find a sustainable balance between reducing energy and maintaining member-consumer satisfaction. Success can be seen not only in the achievement of conservation goals but also in the creation of new programs. An ongoing goal at Great River Energy is to create new programs that provide more opportunities for member-consumer

participation. On average, Great River Energy creates two new energy efficiency programs each year. Recent goals have been achieved by reaching out and partnering with large retailers such as Wal-Mart and Target. Continuing to reach out to local retailers and others across the industry will enable Great River Energy to identify new opportunities that will lead to successful achievement of its strategic conservation goals.

**E. A quantification of the manner by which these programs affect or help determine the forecast provided in response to part 7849.0270 subpart 2, a list of their total costs by programs, and a discussion of their expected effects in reducing the need for new generation and transmission facilities.**

<b>Energy Conservation and Demand Side Management Budgets 2013-2015</b>			
	<b>2013 Approved Budget</b>	<b>2014 Proposed</b>	<b>2015 Proposed</b>
<b>Energy Conservation</b>			
Residential	\$6,394,148	\$6,394,148	\$6,394,148
Commercial	\$2,605,852	\$2,605,852	\$2,605,852
Income Eligible	\$1,189,076	\$1,189,076	\$1,189,076
<b>Total</b>	<b>\$10,189,076</b>	<b>\$10,189,076</b>	<b>\$10,189,076</b>
<b>Demand Side Management</b>			
Residential	\$6,178,798	\$6,178,798	\$6,178,798
Commercial	\$388,839	\$388,839	\$388,839
<b>Total</b>	<b>\$6,567,638</b>	<b>\$6,567,638</b>	<b>\$6,567,638</b>
<b>Total Budget*</b>	<b>\$16,756,714</b>	<b>\$16,756,714</b>	<b>\$16,756,714</b>

\*2013-2015 Budget projections are based on the statutory mandated spending requirements and will change with changes in subsequent years revenues. Currently Minnesota Statutes §216B.241, Subd. 1b. requires that cooperative associations spend a minimum of 1.5% of their gross operating revenues from service provided in the state, excluding gross operating revenues from service provided to large electric customer facilities indirectly through a distribution cooperative electric association. Cooperatives are allowed to use 50% of this minimum spending requirement on load management program expenditures.

# **APPENDIX J**

## **List of Landowners within Proposed Routes**

**THIS PAGE INTENTIONALLY BLANK**

154TH STREET PARTNERS LLC	AAKER JANINE KAYE	AAKER STEVEN A & JANINE	ABHE & SVOBODA INC
AMBROZ CHARLES J & CYNTHIA A	ANDERSON BOYD A & STEPHANIE	ANDERSON BRIAN L	ANDERSON DAVID J & KATHLEEN M
ANDREW PANKRATZ	ANTHONY NOVAK	ARGALL MARGARET E & ARGALL REV	ARGALL MARGARET E & QUALIFIED
ARNOLD AND MARIAN PAVEK	AUDETTE TIMOTHY J & STEPHANIE	BANGS KATHLEEN E	BANKS WESLEY
BARSNESS DAWN M	BARTELDS SHIRLEY A	BARTUSEK BRUCE GLENN	BARTUSEK ELMER J & EVELYN
BARTUSEK MARGARET A	BARTUSEK RICHARD G	BARTZEN THOMAS J & JAMIE K	BAUCHE PAMELA A
BEDEAUX GERALD D & DIANE F	BEITZELL JR JAMES B & JAMES B	BENHARDUS WALTER L & LINDA L	BENSON ANDREW L & KARA L
BERC MARILYN A	BERNDTSON ROBERT J & ELAINE	BETZ MICHAEL W & PATTIE A	BIRD WILLIAM A & ERIN
BIREN PATRICK M & DAWN M	BJ ONE LLC	BOHNSACK LEROY M	BOLKCOM JEFFREY W & JEANNE M
BORCHARDT DENNIS & PATRICIA	BORGLUND RONALD C & JOYCE E	BORK BRIAN & LAURI	BOYSEN WILLIAM & MARIETTA
BRAKE TIMOTHY J & DEANNA K	BRANDT DOUGLAS G & RITA M	BRANTNER BARRY J	BRECKNER RONALD C & JUDITH A
BRESSER RICHARD	BROWN CHET D & BRENDA K	BUCKINGHAM THOMAS & SUZANNE	BUI VINH Q

BUKKILA STEPHEN R & JOAN E	BURTON BRYAN R & YVONNE A	CARLSON PHILLIP A	CARLTON MARSHA P
CASEY FAMILY LIMITED PRTNRSHIP	CASSEM GRANT R & SUSAN K	CAVANOR MARK S & BETH ANN F	CENTRAL BANK
CERVENKA STEVEN J & BARBARA	CHADWICK PARK TOWNHOMES	CHAV HENG	CHLAN FAMILY
CHLAN JR ALBERT J ET AL & C/O	CHLAN KENNETH M & CATHY M	CHLAN MICHAEL	CHLAN RICHARD A
CHLAN RITA	CHLAN RONALD J & KATHLEEN M	CLARK KURTIS W & AMY	CLOUTIER DAVID C & LAURA L
COWAN SCOTT A	CUNDIFF DANIEL	CURTIS JAMES B & CATHY L	DAHL GENEVIEVE K
DANIEL R KUBES FAMILY TRUST	DANKERS STUART L & LINDA L & T	DEDEN JOSHUA G & ANNETTE M	DEGROSS RALPH M & BRENDA A
DELONG DOUGLAS M	DIANE WEYRICK	DIETZ MARY E	DOELZ PAUL W & EUNICE A
DOMJAN MIKLOS & CARMEN	DOUGLAS FETTE	DREW CHRISSIE R	DUALE MOHAMED & QUEEN HANSHI
DUDGEON TROY R & JENNIFER L	EAGLE CREST RENTAL LLC	EARL LARRY E	EITREIM DANIEL M & REBECCA JO
ELEANOR SIREK	EMIL AND ANGELA SIREK	ENGELKEN RONALD B & GLORIA G	ERICKSON C MARVIN & KAREN
ERICKSON CHRISTOPHER & ANNA M	ERICKSON GARY & MARGARET A	ERICKSON LESLYE M	ERICKSON MICHAEL L & SANDRA
ERKEL ROBERT L & KATHLEEN J	ETTER JR GERALD E	FAHRENKAMP DONALD D	FISCHER GERALD W & LAURE J



FJORDBAK NORMAN E & BETTY L	FLANAGAN THOMAS J & KERRI L	FLATEN JEFFREY C & MARY K	FLINK THOMAS J
FOLGER THOMAS J	FORBORD WILLIAM V & ELIZABETH	FOSTER KENT M & LORI A	FOX ROBIN A
FRANDRUP SHASTA R	FRANK PAUL	FRIEDGES CHARLES	FRIEDGES TRACEY R
GALLUP DAVID A	GILES RICHARD D & MARLENE A	GILKEY SCOTT C & LAURA G	GOODELL JEFFREY B & JACQUELINE
GR PROPERTIES INC	GRABER JESSE B	GRAHAM DAVID J & GRETCHEN M	GRANT ERIC J & JACKIE J
GRIEP CHARLES A & ROBERTA J	HAILSTONE MARK H & MELODY A	HANDZIJA HARIS	HANSON BRENDA A
HANSON CHAD	HANSON GEORGE H	HANSON RONALD G & ELIZABETH	HAUGH JAMES M & CATHERINE C
HAVLICEK MOLLY & TIM	HAWKINSON JAMES P & BEVERLY R	HEDLUND MARK A & JANICE M	HEISE KEVIN & JOAN
HENNEPIN PARK RES DIST	HENNING JEFFREY E & LUCILLE A	HENRY SCOTT J & LYNETTE M	HIRMAN DENNIS & SANDRA L
HOLCOMB KELLY L	HOLM PAUL H & JACQUELYN M	HOLMES RANDY R & DEBRA L	HONKEN PAUL E & SUSAN A
HOREJSI GREGORY J & DEBORAH L	HOSEY LAWRENCE	HOWARD LAND GROUP LLC	HUSEBY STEVE M & ANN M
JACOBS SUSAN M	JAMES SCHMITZ	JAMES TUPY	JAXE PROPERTIES LLC & C/O JAME
JERRY SIREK	JLS SERVICES LLC	JOEL AND MARY OLSON	JOHN AND MARIE NOVAK

JOHNSON BRAD C & TAMMIE L	JOHNSON DEAN R & JUDY M	JOHNSON DOUGLAS S & JOYCEANN M	JOHNSON GARY E & KAREN P
JOHNSON MARTIN P & KELLY N	JOHNSON REID P & CYNTHIA A & J	JOHNSON STEVEN P & SUSAN M	JURGENSEN NANCY K
KACK TODD L & JULIE A	KARAN DAVID & SUSAN	KASTEN KURTIS K & VICKY L	KATH JACKIE
KEARNEY JAMES J	KEIMIG JEFFREY J & TERRI L	KELLY MICHAEL G & CHRISTINE L	KERN MARY LOU
KETTERLING JAMES J & LYNN D	KISSOON DEONARINE & KATHLEEN	KJOS MICHAEL T & ANN M	KLETT JAESEN R
KNIGHT ARTHUR F & STEPHANIE M	KNUTSON TREVOR D & LEANNE T	KOEHNEN DANIEL P & MARGARET	KOHLHOF MICHELLE & JOHNATHON
KOLL ERIC T & ROBIN C	KOSKOVICH JAMES T	KRUEGER NATHAN A & TRACY	KRUGER KRISTOPHER L & LISA A
LA LA LA LLC	LARSEN GORDON N & DIANE A	LASALVIA ANTHONY J & PAULA J	LAURSEN PAUL A & RUTH A K
LAWRENCE AND JOYCE ADAMEK	LEAM HOUTH & TY LIN	LEGACY HEIGHTS LLC	LEIN BRIAN R & BRENDA K
LEIRA PROPERTIES LLC	LEPLEY REBECCA A	LINDSOE CORY M	LOVEJOY HARVEY & DIANE
LOVELETTE DONALD & CONSTANCE	LUNNEY DANIEL T & RAELEE A	LUZAR MICHAEL S	LYSENKO ANATOLIY & LUYBOV
MAHONEY JOHN B & JOAN T	MAHOWALD CLAUDE A & JANET & LI	MANDERS SIDNEY V JR & ELAINE A	MANTHE MITCHELL D
MAQSUDI HAMID AZIZ & AQELA SAR	MARIE NYBO	MARK MICHEL	MARK PAVEK

MARK VESELY	MARTIN PETER E	MATT AND ROBIN MCKINLEY	MATTSON WAYNE H & SHARON D
MCCALVY DANIEL J & LISA M	MCGREGOR MARK R & BARBARA A	MCLAUHLIN JAMES P	MCPHAIL GREGORY J & ROBYN M
MEDIN LESLIE	MEDLAND MARLOWE P	MEINKE ROBERT A	MESENBRINK CONSTRUCTION
MESENBRINK JOHN E & MARY C	MESSER MARY JANE	MEYER SHAWN G	MICHEL ROBERT D & CINDY L
MIKUNDA MICHAEL V & DIANE G	MINN VALLEY ELEC COOP	MISHUK BRIAN & KERRY MISHUK	MONSON ALICE GAIL
MOORE SANDO S	MOSKOVKIN SERGEY	MUSCATO STEPHEN & JOY W	NAGPAL ANJU
NELSON DEAN	NELSON ERIC C	NERUD DANIEL J & DAWN E	NGO HIEN T & RANDY VO
NGUYEN HONG T & TAI D	NGUYEN LUCIENNE & HA	NGUYEN THANH N & MY T & ERIC H	NIEMANN LORRAINE S
NIESON JASON S & SHANNON L	NORTHERN STATES POWER CO	NORTHERN STATES POWER CO & PRO	NOVAK JOHN J & MARIE A
NYBO JAMES C & GAYLE T	ODEGARD THOMAS R & KIMBERLY A	O'DONNELL JAMES R & DEBRA K	OELTJEN BRET A & LISA L
OLSON TIMOTHY WILLIAM	OPHUS TIMOTHY J & JENNIFER	OSTER DOUGLAS	OVERCASHIER RODNEY & TERESA
PAHL CHRISTOPHER D	PALMER SCOTT & SUSAN	PALMQUIST MARK S & ALEXANDRA M	PARKER BRUCE J
PATTERSON WILLIAM & GWENDOLYN	PAUTZKE KENNETH E	PENDINO AMY & DMYTRI	PETERSON BRYAN D & CARINA A

PEXA BRYAN F & BONNIE M	PEXA DALE & FRANCES	PEXA EMIL A & BRENDA L	PEXA ROBERT J
PHELPS TERESE & RYAN HIGGINBOT	PHILIP A TENNEY LIVING TRUST	PIEPER DANIEL J & ANN M	PIERRET JEFFREY J
PLADSEN TODD F	POKORNY WAYNE A & CATHERINE	POPOVICH MARKO & KELLY WALL	PRIOR LAKE CITY OF & CITY MANA
PRIOR LAKE MINI STORAGE INC &	PROGRESS DEVELOPMENT	PURCELL DENNIS J	PYLE RICHARD H & SHARI L
RABENORT GREG A & MARY E	RADLOFF JEFFREY J & TONI K	REES SCOTT A	REM METRO SERVICES
REMER CHRISTOPHER D & SUSAN M	RERAT SHIRLEY A & % EUGENE RER	RICHTER KERSTEN J	RIDLEY AARON JOHN
RIEF MICHAEL J	RIESGRAF ASHLEY M	RIVER CREDIT LLC	RIVERA LISA R & JASON D
ROCK ANDREW P	RONALD AND JAYNE STICHA	RONALD VESELY	RONNING SCOTT A & KAREN A
ROONEY CHRISTOPHER & CHRISTINE SAVAGE MEDICAL BUILDING LLC	RUNNING GREGORY L & DIANA M	SABALASKEY LAURA J	SANDEEN CHRISTOPHER & CHRISTY SCHALWIG PROPERTIES LLC
SCHMIDT CHARLES A	SCHMITZ JAMES C & SHARON J	SCHAFFER SCOTT E	SCHUENEMAN GARY
SCHULTZ ADAM D & KIMBERLY M RZ	SCHULTZ ORVILLE	SCHULTZ ORVILLE O & BARBARA	SCHUMACHER KARL G & XIANMEI SH
SCOTT COUNTY HWY DEPT	SCOTT COUNTY HWY ENGINEER	SCOTT COUNTY TAXATION DEPT	SELBY SCOTT E & KIRSTEN R

SELLIN CYNTHIA L	SEURER LAURA & ATTN: GARY A ER	SHANNON FARLEY	SHARKEY MARGARET L
SHEFCHIK ANDREW	SHIMOTA EDWARD J & DOROTHY M	SHIMOTA FRANCIS J & DEBRA A	SHIMOTA WILBERT F & CAROLINE
SIEBERG TIMOTHY & MICHELE	SIMONES DANIEL J & LINDA S	SIMONES JONATHAN L	SIPPEL JAMES T & KRISTIN K
SKLUZACEK JOSEPH & KIMBERLY	SMISEK ARNOLD J & MARY A	SMITH SCOTT L & KRISTEN J	SNYDER CRAIG E & WENDY L
SPELBRING CHAD D & CINDY L	STACH ROBERT & MAARI	STEELE LYNDON L	STENSBY DANIEL L & ROXANN P
STEVEN AND ANDREA SMYTHE	STEVEN AND BARBARA CERVENKA	STEVERMER ERIC E	STICHA MARVIN D & LUANN
STIELE DOUGLAS F & KELLEY M	STRAWHACKER TIMOTHY A & LISA	STRIPSKY KELLI M	SUTHERLAND RYAN
SWEERS BENJAMIN & JULIE	TATTERSALL CRAIG J & MELISSA S	THE RONALD WAYNE BAAR LIVING T	THEODORE AND DEANA NOVAK
THOMAS SIREK	THOMPSON GENE A & BARBARA A	THREE RIVERS PARK DISTRICT	THYDEAN CHRIS J
TIMOTHY AND JULIE LOFTUS	TORBORG KENNETH P & BEVERLY M	TRENCE PETER G	TURNER JAMES D
TURNGREN MELANIE J	TWIN CITIES HABITAT FOR HUMANI	UNDERHILL TODD M & BARBARA B	UY MARTINEE R & MELISSA T K
VAREBERG KEVIN & TAMMY	VELISHEK TIMOTHY A & LISA J	VERNON AND TAMMY KES	VICTORY FIELDS LLC
VILANDRE KRISTA L & KARLA A	VU DANG M & TUYET T NGUYEN	WAGNER DARIN L	WAGNER DONALD J & JUDY L

WAGNER RALPH M &  
GERALDA & LIV

WASBOTTEN JAMES &  
SANDRA E

WERSAL GERARD G &  
CYNTHIA M

WILLIAM AND AMY  
SIREK

WILSON CATHLEEN A  
& WILLIAM W

WYATT 1-KEARNEY  
CREDIT RIVER L

ZASTROW WILLIAM F  
& AMY K

ZWEBER LEON &  
JUDITH

WAGNER RANDAL A &  
LOU ANN

WATRY SCOTT A

WETZEL LISA T &  
JOHN A DUFFY

WILLIAM AND MARY  
SIREK

WIXON DANIEL M

YATES JAMES E &  
CHRISTINE S

ZWEBER BENJAMIN M  
& MARY C

WAGNER TIMOTHY R  
& MARY K

WAYNE M & MARY K  
TONSAGER REVO

WEYRAUCH JACK G  
& LEANNE J

WILLIAM BRANDT

WOZNEY  
ALEXANDER J

YOUNG  
CHRISTOPHER R &  
DIANE K  
ZWEBER  
CHRISTOPHER J &  
WENDY J

WARMKA WARREN T  
& RUTH A

WELLS DIRK E

WHITE BONNIE K

WILLIAMSON DENISE  
G

WROBLEWSKI  
EDWARD J & SARAH  
A  
YULE JUSTIN M

ZWEBER JON J & LISA  
M