

**ATTACHMENT G – Decommissioning Plan and
Cost Estimate**

DECOMMISSIONING PLAN

Buffalo Ridge Wind Energy Facility

Docket No. IP-70061/WS-19-394

Buffalo Ridge Wind, LLC

REVISED January 27, 2022

Decommissioning Plan for the Buffalo Ridge Wind Energy Facility

1.0 INTRODUCTION

1.1 Background

Buffalo Ridge Wind, LLC (“BRW”) has filed a Site Permit application with the Minnesota Public Utilities Commission (“Commission”) to construct and operate an up to 106 Megawatt (“MW”) wind energy facility that will consist of 40 wind turbines, either 36 GE 2.82 MW turbines and 4 GE 2.52 MW turbines or 36 GE 2.82 MW turbines and 4 GE 2.32 MW turbines, as well as associated 20.6 miles of access roads, 28 miles of underground electrical collection, an approximately 1,400-foot-long 115kv generation tie line (gen-tie), and associated facilities known as the Buffalo Ridge Wind Energy Facility (“Buffalo Ridge” “Project”). See **Attachment A** for a figure showing the Project Area and facilities. The Project is located in Lincoln and Pipestone County, Minnesota and spans approximately 17,600 acres of farmland. All project infrastructure and activities will be in Lincoln County. A power purchase agreement has been signed with Great River Energy for a duration of 25 years and commercial operation date (COD) is anticipated for the end of 2022.

1.2 Decommissioning Plan Objective

At the end of the Project’s useful life, BRW plans to decommission the facility. The purpose of this Decommissioning Plan is to establish the protocols for disassembly of the wind energy facility at the end of its useful life and to financially guarantee funding of the decommissioning process so that there is assurance that the site can be restored to a condition as close to a pre-construction state as feasible. As part of this Decommissioning Plan, BRW has provided a third-party, detailed, estimated cost schedule, prepared by Atwell, LLC, for Project decommissioning activities (see **Attachment B**).

BRW will furnish a financial surety, bond, or other form of surety equal to the total estimated cost schedule to Lincoln County. That financial surety will ensure that if BRW is no longer solvent to finance the decommissioning process, adequate funds will be available to Lincoln County for administering and financing the decommissioning and reclamation process.

This Decommissioning Plan has been created to establish the approach and estimated cost for the following activities:

- Site Preparation and obtaining of necessary permits required for the structural dismantling activities (crane pads, crane paths, etc.)
- Installation of soil erosion and sedimentation control best management practices (BMPs)
- Disassembly and removal of existing turbines
- Abandonment or removal of existing infrastructure associated with the turbines and the gen-tie line
- Scarification and reseeded of disturbed areas, where applicable
- Establishment of vegetation on disturbed soils
- Mitigation for potential impacts on sensitive environmental features including agricultural

soils

- Mitigation for potential impacts to agricultural facilities, agricultural drainage tiles, and public drainage ditches, if affected

The Decommissioning Plan has been developed per the following guidelines:

- Conformance with Minnesota Administrative Rules 7854.0500, subp.13
- Energy Environmental Review and Analysis (EERA) Large Wind Energy Conversion System (LWECS) Application Guidance
- EERA Recommendations on Review of Solar and Wind Decommissioning Plans (Commission Docket Number E999/M-17-123)

1.3 Anticipated Life of the Project

BRW estimates that the Project will have a useful life of at least 25 years. Once the Project has reached its useful life, this Decommissioning Plan intends to lay out the steps necessary to reconstitute the land to the condition it was in prior to operation of the Project and guarantee that BRW has a surety, bond, or other form of surety in place that will cover the cost of that decommissioning effort.

2.0 DECOMMISSIONING PROCESS PROTOCOL

2.1 Decommissioning Notification

Once BRW has determined that the Project has reached the end of its useful life and is ready to be decommissioned, BRW will first notify participating landowners, local governments, and the Commission of initiation and commencement of planned decommissioning activities via a mailed letter 10 days prior to those planned activities. This letter will also provide the name and contact information of an individual designated by BRW to manage landowner inquiries. Once restoration is completed, BRW will notify all participating landowners, local government, and the Commission of decommissioning completion via a mailed letter within 30 days.

2.2 Decommissioning Permits and Approvals

Table 1 provides a list of permits and/or approvals that may be required for decommissioning of the Project. Permits will be assessed on a project-specific basis for applicability prior decommissioning.

Table 1. Permits and Approvals

Regulatory Authority	Permit/Approval
Federal	
U.S. Army Corps of Engineers(USACE)	Federal Clean Water Act Section 404 coordination (General, Individual, or Nationwide Permit if required)

Regulatory Authority	Permit/Approval
U.S. Fish and Wildlife Service	Coordination for review of threatened and endangered species
U.S. Environmental Protection Agency (Region 5) in coordination with the MPCA	Spill Prevention, Control, and Countermeasures (SPCC) Plan
Federal Aviation Administration	Notice of Proposed Construction or Alteration (Determination of No Hazard - Form 7460-1)
	Notice of Actual Construction or Alteration (Form 7460-2)
State of Minnesota	
Minnesota State Historic Preservation Office (SHPO Office)	Cultural and historic resources review including State and National Register of Historic Sites review
Minnesota Office of State Archaeologist (OSA)	Informal OSA consultation for archaeological resources review
Minnesota Pollution Control Agency (MPCA)	Clean Water Act Section 401 Water Quality Certification (Individual Permits only, conditionally certified under General and Nationwide Permits)
	Case-specific Beneficial Use Determinations
	NPDES/SDS – MPCA General Stormwater Permit for Construction Activity
Minnesota Department of Natural Resources	License to Cross Public Lands and Water
	Temporary Projects General Permit No. 1997-0005 (construction dewatering and dust control)
	Endangered species coordination
	Public Waters Work Permit
Minnesota Board of Water and Soil Resources/Rock County Soil and Conservation District	Wetland Conservation Act Local Governmental Unit approval
Minnesota Department of Transportation	Oversize/Overweight Permit for State Highways
	Access/Driveway Permits for MnDOT roads
	Utility Permit

Regulatory Authority	Permit/Approval
Local	
Lincoln County	Drainage Permit
	Roadway Access Permit
	Over-weight and Over-width Load Permit
	Working in Right-of-Way Permit
Townships	Right-of-way permits, crossing permits, road access permits, and driveway permits

2.3 Decommissioning Preparation Activities

The first step in the Decommissioning Plan will be for BRW to contact all participating landowners to determine their preference on removal or abandonment of infrastructure. For example, some landowners may prefer to leave access roads in place that benefit their farming activities. Electrical collection lines may also be left in place at the landowner's request to reduce disruption of their fields.

Per section 11.4 of the LWECS Application Guidance document, BRW is providing the decommissioning, abandonment, and removal condition language for reference from the landowner lease agreements below:

Removal of Improvements. (a) Within eighteen (18) months after termination or expiration of the Easement Term, Operator shall, unless otherwise agreed by Owner, remove all of the Improvements on the Owner's Property and restore the Owner's Property to its approximate original condition that existed before Operator constructed its Improvements all at Operator's sole cost and expense. At termination or expiration of the Easement Term, Operator shall be required to remove facilities down to a level of forty-eight (48) inches below grade and return the grade to a condition comparable to conditions prior to Operator's installation of Improvements on the Owner's Property. If Operator fails to remove any portion of the Improvements or restore the Owner Property as required within the required time period, that portion of the Improvements shall be considered abandoned by Operator and Owner may remove that portion of the Improvements from the Owner's Property and dispose of it in its sole discretion without notice or liability to Operator. In the event Operator fails to remove any of the Improvements or restore the Owner's Property as required, and Owner removes any portion of the Improvements or restores the Owner's Property at Owner's expense, Operator shall reimburse Owner for all reasonable costs of removing that portion of the Improvements or restoration of the Owner's Property as required by the Site Permit and/or this Agreement, less any salvage or resale value received by Owner, within thirty (30) days after receipt of an invoice from Owner. If Operator fails to pay or reimburse Owner for any decommissioning, removal or restoration costs, Owner may withdraw such funds from the Decommissioning Security or pursue any other lawful remedy or recourse.

Once the landowner coordination has occurred and the extent of disturbance areas are understood, BRW will develop a Storm Water Pollution Prevention Plan (SWPPP) and submit for a National Pollutant Discharge Elimination System (NPDES) permit based on the anticipated disturbances for both demolition and new temporary construction required for component removal. Crane pads and potential crane walks will be installed to support the turbine removal process after soil erosion BMPs are in place. Other permits (such as those that may be needed for impacts to wetlands or other sensitive environmental features) will also be obtained, as applicable.

2.3.1 Erosion Control & Sedimentation Control Measures

General erosion control measures will be utilized, as appropriate, in the SWPPP and consist of the following BMPs:

- Silt fence or straw wattle installation on the downslope and adjacent to sensitive water features
- Slopes greater than four to one should be protected with erosion control blankets or mulch blankets
- Stabilization of disturbed soils with seed application
- Stripped topsoil shall be placed in soil stockpiles and placed in a manner to not interfere with natural drainage to waterways which could promote soil erosion. Topsoil stockpiles should be surrounded by either silt fence or straw wattles. If the stockpile is to remain for an extended period of time, it should be temporarily seeded.
- Temporary construction entrances should be established consisting of 1”x 3” aggregate to reduce erosion onto roadways.
- Dust control
- Dewatering activities requiring a filtration bag

Before any demolition begins, the Project will first be disconnected from the electrical grid by following all safety energy industry standards and best practices to allow for the safe dismantling of the project components including turbines, electrical collection lines, and substation components. The general process for disconnecting the Project from the grid is as follows:

- Power down and lock all turbines to prevent the flow of electricity from the Project to the substation
- Place generator step-up transformer (GSU) breaker in open position (if this is an option on GSU)
- Place the GSU disconnect switch in the open position
- Place collection feeder breakers in open position to electrically disconnect the Project
- Place the collection feeder disconnect switches in the open position
- In coordination with the Transmission Operator, de-energize the gen-tie line between the Buffalo Ridge wind plant/ substation and the Point of Interconnection (POI) substation, which will effectively de-energize the main step-up transformer (GSU)
- Remove the POI connection wires from the substation and gen-tie line, disconnecting Project substation from Grid
- Safely begin the dismantling of substation, turbines, and electrical components of the Project

2.4 Removal of Facilities

Decommissioning will include the dismantling and removal of the wind towers, wind turbine generators, foundations, meteorological towers, access roads, underground collection lines, pad mounted transformers, collection substation, gen-tie line, and the operations and maintenance (O&M) facility to a depth of four feet, unless requested by the landowner or other entity. Turbine tower sections will be dismantled utilizing cranes. A single large crane is typically used to disassemble the turbines, and smaller cranes would lift the parts onto trucks to be hauled away. Meteorological towers will also be similarly removed.

After dismantling and excavating the facility onsite, high value components will be removed for scrap value. The remaining materials will be left on the landowner property where expressly requested by the landowner or will be reduced to transportable size and removed from the site for disposal. Unsalvageable materials will be disposed of at authorized sites in accordance with applicable regulations.

Following the dismantling and removal of Project infrastructure, BRW will return the Project Area as close to preconstruction conditions as reasonable in accordance with the lease agreement between the landowner and BRW.

2.4.1 Turbines and MET Tower

The disassembly and removal of this equipment will essentially be the same as its installation, but in reverse order. For turbines, the rotor (hub and blades) are removed from the nacelle and, with the help of a smaller crane, turned horizontally and set on the ground. Next, the nacelle will be removed from the top of the tower, followed by each portion of the tower. Turbine tower portions will be sized on-site for transport by regular sized haul trucks (no oversize permits or specialized equipment needed). Once the turbine rotor has been removed, a crew and small crane will disassemble it into the hub and three loose turbine blades. When the rotor is disassembled, the blades will be sized for transport by regular size haul trucks (no oversize permits or specialized equipment needed). The hub can also be removed once it is disassembled from the blades. Turbine foundations will be removed to a depth of four feet. BRW will work with landowners regarding whether the landowner prefers to keep extracted concrete on their property. If landowners prefer to keep extracted concrete, the concrete will be crushed and provided to the landowner. If the landowner prefers not to keep the extracted concrete, the concrete will be reduced in size by excavator attachments and transported for disposal off-site.

The MET tower will also be removed in a similar fashion to the turbines. A small crane will be used to dismantle the structure from the top down and will be loaded onto trucks to be removed from the site.

2.4.2 Access Roads

Access roads may require upgrading / widening to allow removal of oversized turbine parts from landowner property and will be assessed at the time of decommissioning. BRW will work with landowners regarding whether the landowner prefers to keep the access roads in place following decommissioning. Any access roads that were upgraded or widened to facilitate decommissioning, will be returned to their original state following decommissioning if the landowner chooses to keep the access roads. In the event landowners do not want to keep the access roads, or portions thereof,

the access roads will be removed, and the land will be restored. Any geotextile fabric that is encountered during demolition will be taken to an approved landfill.

2.4.3 Underground Collection and Pad Mounted Transformers

Where feasible, all underground collection lines buried above four feet below the surface will be removed unless requested by the landowner or other entity to remain in place. BRW will work with landowners or applicable entities to determine if underground collection lines may be left in place when located above four feet below the surface to minimize impacts to the environment. If the underground collection lines are to be removed, a trench will be opened, and the cables pulled out. The cables will be cut into manageable sections and removed from the site.

Pad mounted transformers will be disconnected from the collection system and wind turbine generators once the electrical system has been shut off and hauled offsite. The concrete pads will be crushed and either hauled offsite or provided to the landowner, if requested.

2.4.4 Collection Substation and O&M

All above ground structures at the collection substation including the conductors, switches, transformers, fencing, and other components will be dismantled and removed from the site. Additionally, the structures at the Project O&M facilities will be removed. All concrete foundations will be crushed and either hauled offsite or provided to the landowner, if requested. Where feasible, all underground infrastructure associated with the substation or O&M, including underground conduits and grounding wires, will also be removed to a depth of four feet, unless it has been negotiated with the landowner that this infrastructure may be abandoned in place.

2.4.5 Gen-Tie Line

Cables will be removed from gen-tie poles, stripped of insulation, and spooled for recycling. The gen-tie poles will be disassembled and loaded onto a trailer. Recyclable parts will then be hauled off to a scrap yard for recycling. The cost estimate presented includes the cost to haul material to the scrap yard. Voids left from the removal of the poles will be backfilled with surrounding subsoil and topsoil and fine graded to provide suitable drainage.

2.5 Salvage and Disposal

After dismantling the Project, high value components will be removed for scrap value. The remaining materials will be left on the landowner property where expressly requested by the landowner or will be reduced to transportable size and removed from the site for disposal. Materials will be disposed where disposal is permitted and where there is capacity for the disposal. Generally, turbines, transformers, electrical components, and towers are refurbished and resold or are recycled for scrap. All unsalvageable materials will be disposed of at authorized sites in accordance with applicable regulations. Decommissioning of the turbines will include removal and transport of generators and towers offsite to disposal facilities and/or sale of towers and generators.

2.6 Hazardous Materials

During decommissioning, hazardous materials will be temporarily stored and utilized. These hazardous materials may consist of fuel, lubricating oil, hydraulic oil, propylene glycol, and other materials required for the decommissioning. Also, decommissioning will require the removal of

pad mounted and grounding transformers that contain large quantities of cooling fluids, likely consisting of mineral oil.

Due to the presence of hazardous materials during decommissioning, there is the potential for spills and/or leaks. The primary concerns associated with these spills and/or leaks are the potential impacts to surface and ground water resources and the potential for soil contamination. A Spill Prevention, Control, and Countermeasure Plan (SPCC) will be created for decommissioning. The SPCC plan will detail the appropriate storage, cleanup, and disposal of hazardous wastes to ensure potential impacts are avoided.

Any wastes generated will be handled and disposed of in accordance with Minnesota Rule Chapter 7045, local rules and regulations, and the site specific SPCC. Any monitoring, transportation, or handling of materials will be conducted by trained and qualified personnel utilizing established procedures and proper equipment.

2.7 Restoration

Following the dismantling and removal of Project infrastructure, BRW will return the Project Area as close to preconstruction conditions as reasonable. BRW will implement the following:

- All areas where infrastructure has been removed will be graded and reseeded, as appropriate.
 - BRW will coordinate with local Natural Resources Conservation Service staff to revegetate non-cropland and pasture areas disturbed during decommissioning with native seed mixes appropriate to the region. Reseeding with native seed mixtures will be used on restoration areas except in cropland areas and in areas where landowners indicate preference for other seeding plans. Reseeding of cropland areas will be conducted in coordination with the landowner.
 - After removal of all foundation materials, the areas will be filled with clean, compatible sub-grade material compacted to a density similar to the surrounding sub-grade material.
- Topsoil will be removed prior to removal of structures from all work areas and stockpiled and separated from other excavated material. The topsoil will be replaced to original depth and original surface contours reestablished where feasible. Any topsoil deficiency and trench settling shall be mitigated with imported topsoil consistent with the quality of the affected site.
- Areas compacted by equipment used in the decommissioning may be tilled in a manner adequate to restore the topsoil and subgrade material to a density consistent with the surrounding areas and then will be reseeded. The depth of compaction relief will depend on site-specific conditions.

3.0 COST

The total net cost of decommissioning is estimated to be approximately \$4,705,728. This equates to approximately \$117,644 for each of the 40 turbines that will be decommissioned. The gross cost of decommissioning is \$5,576,528, which equates to approximately \$139,414 per turbine.

4.0 SCHEDULED UPDATES

A final Decommissioning Plan incorporating comments and information from the permit issuance process and any updates associated with the final construction plans, will be filed with the Commission at least fourteen 14 days prior to the pre-construction meeting. The Decommissioning Plan will be updated every five years following the commercial operation date. The Decommissioning Plan will also be updated if there is a change in ownership. Table 2 below provides an anticipated schedule for updates of the Decommissioning Plan for the 25 year life of the Project.

Table 2. Update Schedule

Version	Date
Update 1	2027
Update 2	2032
Update 3	2037
Update 4	2042
Update 5	2047

5.0 DECOMMISSIONING SECURITY

BRW will establish a financial surety, bond, or other form of surety with Lincoln County for the total estimated decommissioning costs located within the county. A preliminary form of the agreement was shared with Lincoln County on February 25, 2020. It is anticipated that financial assurance will be provided for 50 percent of total decommissioning costs by year 10 of operation and fully funded by year 20 of operation, prior to the expiration of the PPA. However, the amount of the assurance, a timeline for funding of the assurance, a description of how the amount of security available will be reconciled with the changing cost estimates reflected in the Decommissioning Plan, which will be updated every five years, and the proposed beneficiary of the security will be finalized with Lincoln County prior to Project operation.

Attachment A

Buffalo Ridge Wind Project Area & Facilities Map

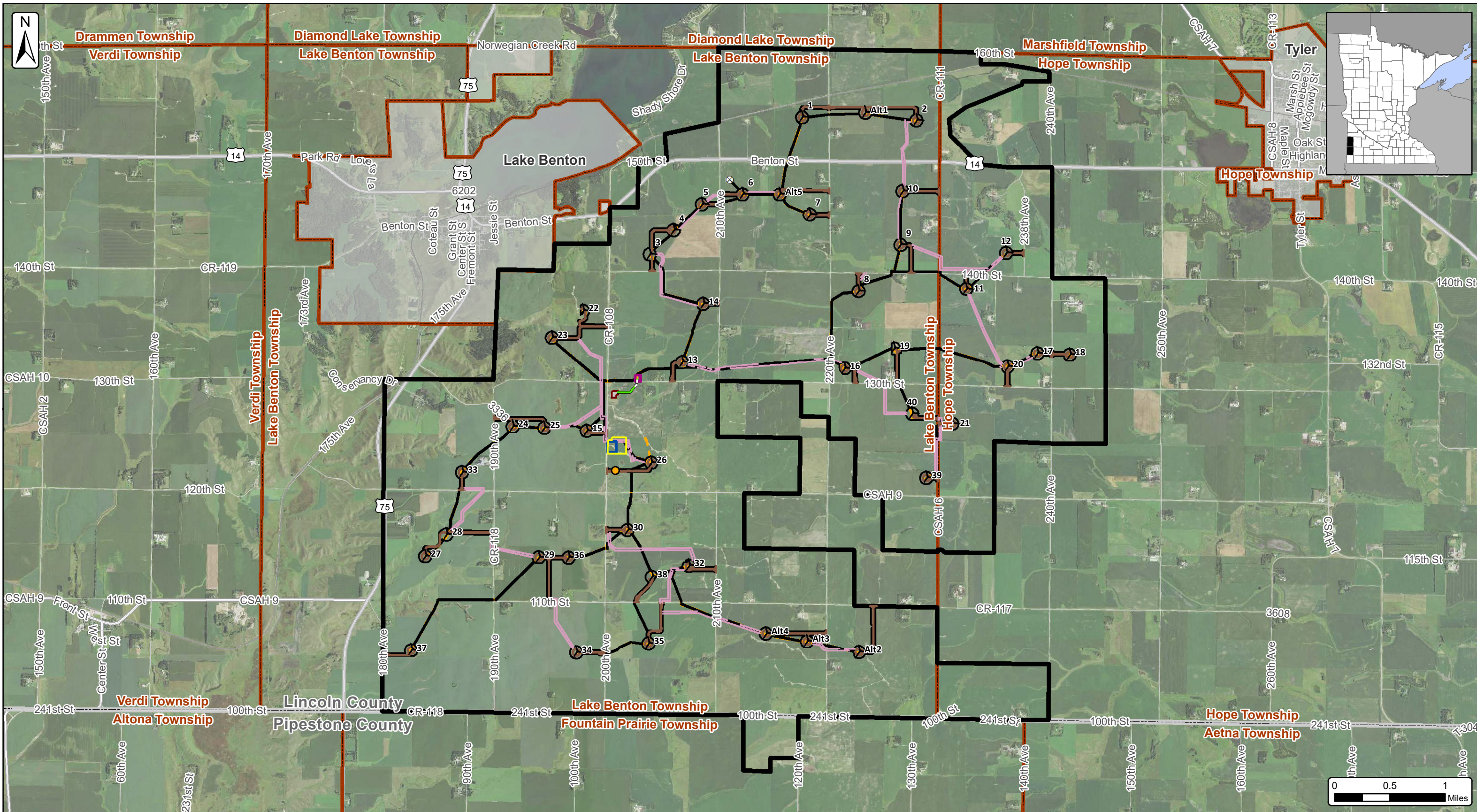

Buffalo Ridge Wind, LLC
Figure 1 - Project Area and Facilities
 Lincoln County & Pipestone County, Minnesota
 Date: 1/27/2022

<p>Project Facilities</p> <ul style="list-style-type: none"> Turbine Layout (11/12/2021) ADLS Location MET Tower Proposed Construction Easement (12/15/2021) Proposed Generation Tie Line (12/02/2021) Proposed Crane Path (12/15/2021) 	<ul style="list-style-type: none"> Proposed Access Road (12/15/2021) Existing Buffalo Ridge Substation Proposed Collection Corridor (12/15/2021) Proposed Laydown Yard/Batch Plant (12/09/2021) Proposed Substation (10/18/2021) Proposed O&M Area (05/16/2019) 	<ul style="list-style-type: none"> Project Area 5/9/2019 (±17,609 Ac.) Counties Townships Cities
--	---	--



SOURCE: USDA NAIP
IMAGERY 2019

Attachment B

Buffalo Ridge Wind Project Cost Estimate



BUFFALO RIDGE WIND PROJECT – DECOMMISSIONING COST ESTIMATE

To: Danell Herzig, Buffalo Ridge Wind, LLC

From: Timothy Jones, Civil Engineer, Atwell, LLC

Date: January 27, 2022

Re: **Buffalo Ridge Wind Project – Third Party Decommissioning Estimate**

Cost Estimate

Estimated Cost of Decommissioning

Buffalo Ridge Wind, LLC (BRW) retained Atwell, LLC (Atwell) to develop an independent, third party cost estimate for the decommissioning of the Buffalo Ridge Wind Project (Project). The decommissioning cost estimate provided herein includes an estimate of the cost to return the site to a condition compatible with the surrounding land and similar to the conditions that existed before development of the Project. This estimate is based upon the described Project and decommissioning methods summarized in the Buffalo Ridge Wind Energy Facility Decommissioning Plan dated January 27, 2022 and associated with Minnesota Public Utility Commission (PUC) Docket Number IP-70061/WS-19-394.

Included in the estimate are the costs to decommission the power generating equipment associated with the Project, as well as the costs to retire the Project facilities, with all turbine foundations removed to a depth of 4 feet below grade. These costs are offset by the estimated revenue that will be received for scrap value of steel, aluminum, and copper equipment. No resale of the Project facilities for reuse is considered and thus, accordingly, the cost estimate provided herein is a “no resale” estimate.

At the time of decommissioning, the above-grade steel structures and turbine nacelles are assumed to have significant scrap value that will offset a portion of the cost to remove these items. However, the Project will also incur costs for removal and disposal of the wind turbine generator blades, foundations, and other Project facilities, along with the costs for the restoration of the site following the removal of salvageable equipment and disposal of other items.

Table 1. Decommissioning Cost (In Current U.S. Dollars)

Item	Quantity	Unit	Unit Price	Cost Estimate
1.0 Field Activities				
1.1 Field Equipment, facilities, & personnel	1	Lump Sum	\$907,218	\$907,218
1.2 Site Facilities - Rental	1	Lump Sum	\$8,620	\$8,620
1.3 Field Management	15	Weekly	\$18,282	\$274,235
2.0 Substation & Gen-Tie				
2.1 Substation & Switchyard Removal	1	Lump Sum	\$500,000	\$500,000
2.2 Gen-Tie Removal	4	Each	\$2,500	\$10,000
3.0 Tower and Nacelle Units				
3.1 Construct/remove temporary crane pads	40	Each	\$7,593	\$303,720
3.2 Turbine Removal	40	Each	\$30,000	\$1,200,000
3.3 Turbine Foundation Removal	40	Each	\$15,000	\$600,000
3.4 Turbine Sizing & Loadout (Salvage Value)	40	Each	(\$21,770)	(\$870,800)
4.0 Pad Mounted Transformer & Collection Line Removal				
4.1 Pad Mount Transformers	40	Each	\$1,734	\$69,364

Item	Quantity	Unit	Unit Price	Cost Estimate
4.2 Underground collection line (~28 miles of electrical collection line)	28	Miles	\$11,189	\$313,292
5.0 Tower Access and Site Roads				
5.1 Restoration of Gravel Road (~20.6 miles of gravel road)	21,270	Cubic Yard	\$11	\$235,459
5.2 Culvert Removals	12	Each	\$488	\$5,859
6.0 Site Restoration				
6.1 Site Restoration, Seeding, and Revegetation (~20.6 miles access roads, 5.6-acre substation, and 0.5 acres/turbine site)	1	Lump Sum	\$405,000	\$405,000
7.0 Ancillary Equipment Removal				
7.1 Meteorological Tower Removal	1	Each	\$1,681	\$1,681
7.2 ADLS Radar Removal	2	Each	\$1,992	\$3,984
8.0 Administrative & Project Management Tasks				
8.1 Office, Project Management (5%)	5	Percent	\$197,881	\$197,881
8.2 Contractor OH & Fee (13%)	13	Percent	\$540,215	\$540,215
NET TOTAL COSTS:				\$4,705,728
GROSS TOTAL COSTS:				\$5,576,528
<i>Net Cost/Turbine</i>		<i>40 each</i>	<i>\$117,644</i>	
<i>Gross Cost/Turbine</i>		<i>40 each</i>	<i>\$139,414</i>	
<i>Net Cost/MW</i>		<i>106 each</i>	<i>\$44,394</i>	
<i>Gross Cost/MW</i>		<i>106 each</i>	<i>\$52,609</i>	

Cost Assumptions

This estimate is based upon the described Project and decommissioning methods summarized in the Buffalo Ridge Wind Energy Facility Decommissioning Plan dated January 27, 2022. The tasks associated with decommissioning were each estimated separately to include labor requirements, equipment needs, and duration. Production rates were established in accordance with similar decommissioning plans. Labor rates prevalent to the geographic area of the Project were obtained by referencing U.S. Department of Labor wage determinations. Typical average markups that are industry standard were applied for contingency, overhead, and fee. Atwell used the following estimating methods and assumptions as follows:

- Labor costs were developed by reviewing U.S. Department of Labor wage determinations and rates published by RS Means. An average rate was developed that includes base wage, fringe, and payroll tax liability. The final rate used in the estimate is an average of 40 hours standard (ST), and 10 hours overtime (OT) per week, assuming a 50-hour work week during decommissioning activities.
- Equipment rates (commonly referred to as yellow iron rates) used in the estimate are developed based on historical vendor quotes derived from RS Means. Rates include fuel, maintenance, and wear and tear of ground engaging components. Rates utilized assume the use of rental equipment, not owned.
- Mobilization and demobilization costs reflect the actual cost to mobilize equipment, facilities and crew to the Project site. A substantial portion of this cost is for the crane and crew required for turbine removal. This amount does not include the front loading of cost from other tasks.
- Work was estimated on a unit cost basis, priced by task that follows the progression of work from start to finish. Unit costs are developed by including the labor, equipment and production rate required for each individual task. Historical vendor quotes and estimator's experience are utilized to establish the crew, equipment and production for each individual task.
- Turbine removal will require the construction and subsequent removal of temporary crane pads. The estimated cost of crane pads is based on an engineered design from a similar project.
- All concrete foundations will be removed to a depth of 4 feet below grade. Gravel from road removal will be utilized to backfill to within 6 inches of final grade, and then an additional 6 inches of topsoil will be applied. Concrete foundation removal will be accomplished with the use of excavators with concrete breakers. Processed concrete will be transported offsite under the same assumptions as road gravel.
- The costs for temporary facilities have been included in the restoration cost. These include

one office trailer, two storage units, portable toilets, first aid supplies and utilities.

- Field management during construction activities is included in the estimate. These costs include one superintendent, one health and safety representative and two field engineers. These positions are critical to the safe and successful execution of work.
- Contractor Home Office, Project Management, Overhead and Fee can vary widely. As such, averages were developed for the estimate and added as a percentage of total cost. These include 5 percent for Home Office and Project Management, and 13 percent for Overhead and Fee. Note that Contractor contingency costs are not included. Several other miscellaneous costs have been approximated, including permits, engineering, signage, fencing, traffic control, utility disconnects, etc. In the context of the overall estimate, these are incidental costs that are covered in the estimate markups.

**ATTACHMENT H – Typical Generation-Tie Line and
Substation Drawings and Photograph**

Typical Drawings and Photographs

Detail of Proposed Substation and Generation-Tie Line Location..... Page 3

Substation General Arrangement.....Page 4

Substation Profiles.....Page 5

Representative Photo of Collector Substation.....Page 6

Typical Generation-Tie Line Pole Structure.....Page 7

Buffalo Ridge Wind

Detail of Proposed Substation and Generation Tie Line

Lincoln County, Minnesota

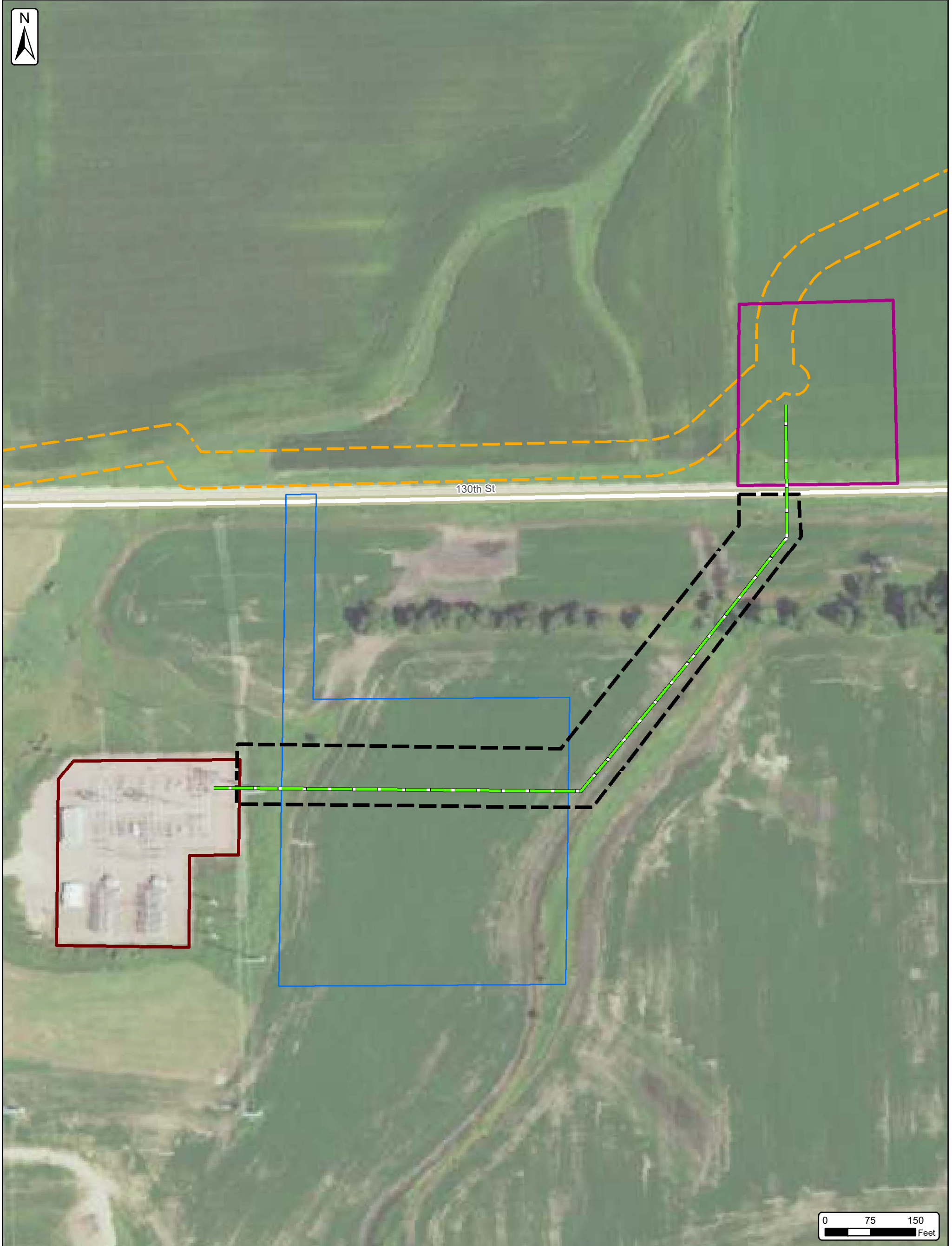

- Proposed Generation Tie Line (12/02/2021)
- Proposed Generation Tie Line Easement (12/29/2021)
- Proposed Substation (10/18/2021)
- Previously Proposed Substation (3/29/2019)
- Currently Proposed Substation (10/18/2021)
- Proposed Collection Corridor (12/15/2021)

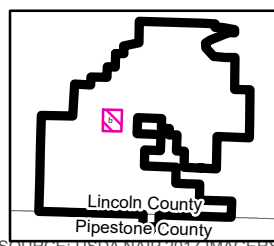

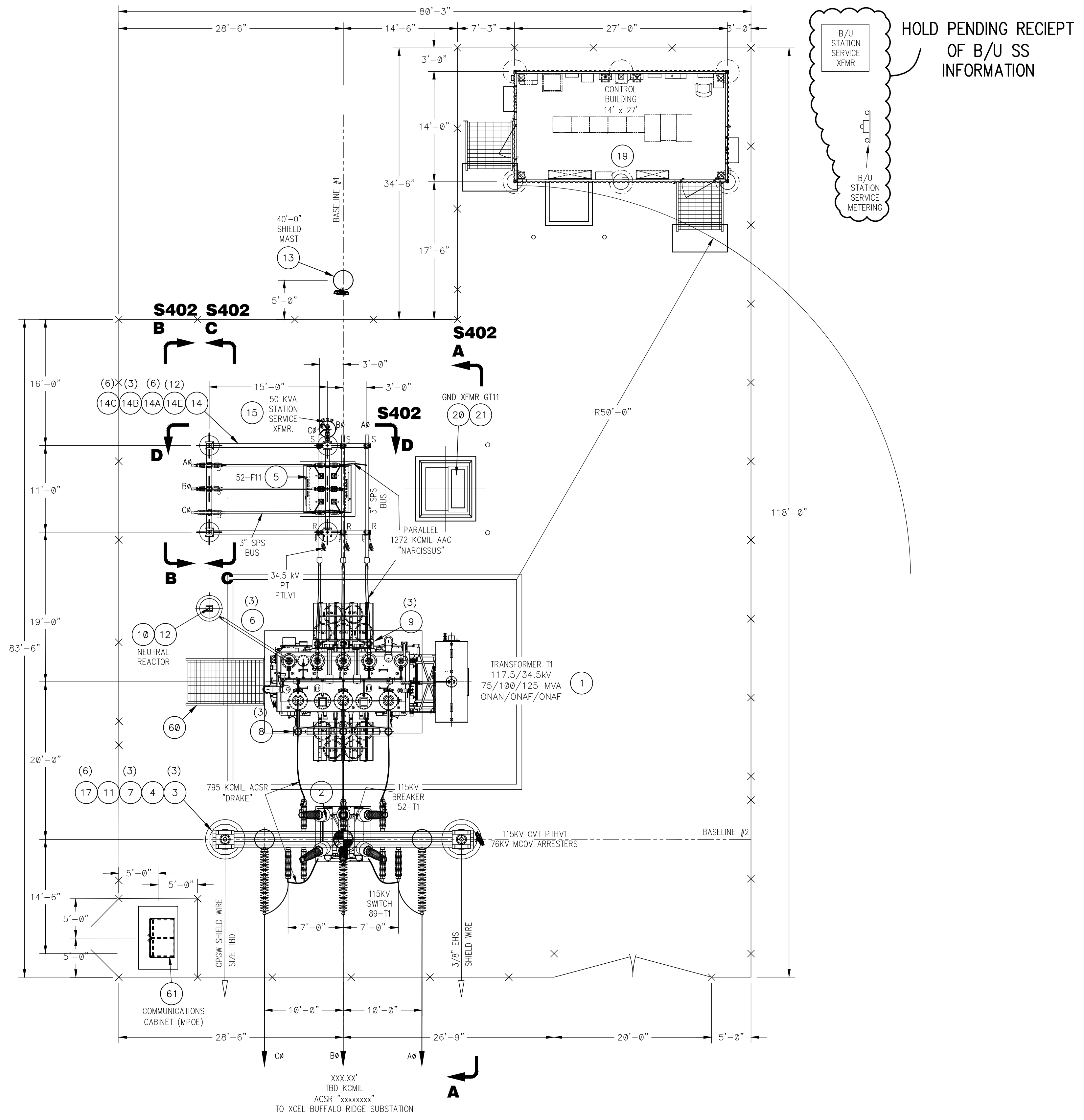

LEGEND
 R RIGID CONNECTION
 S SLIP CONNECTION

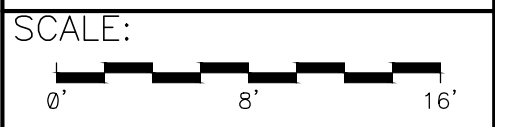

22234
P & E ENGINEERING CO.
 POWER SYSTEM ANALYSIS AND DESIGN
 245 S. 5th Office: 515-989-3083
 P.O. Box 620 FAX: 515-989-3138
 Carlisle, IA 50047 peengr@peengr.com

REV	DESCRIPTION	DESIGNED	DFTR	APPR	DATE	INCEPTION
C	UPDATE SUBSTATION NAME	P&E	P&E	JJS	2022-01-14	DATE 2020-08-18
B	REVISED PER NEER COMMENTS	P&E	P&E	JJS	2021-11-12	DESIGN P&E
A	ORIGINAL DESIGN	P&E	P&E	JJS	2020-08-26	DFTR P&E
						APPR JJS

ISSUED FOR PERMIT

BUFFALO RIDGE WIND, LLC
 STRUCTURES & EQUIPMENT PLAN

REV C
 DWG NO E9614-S401

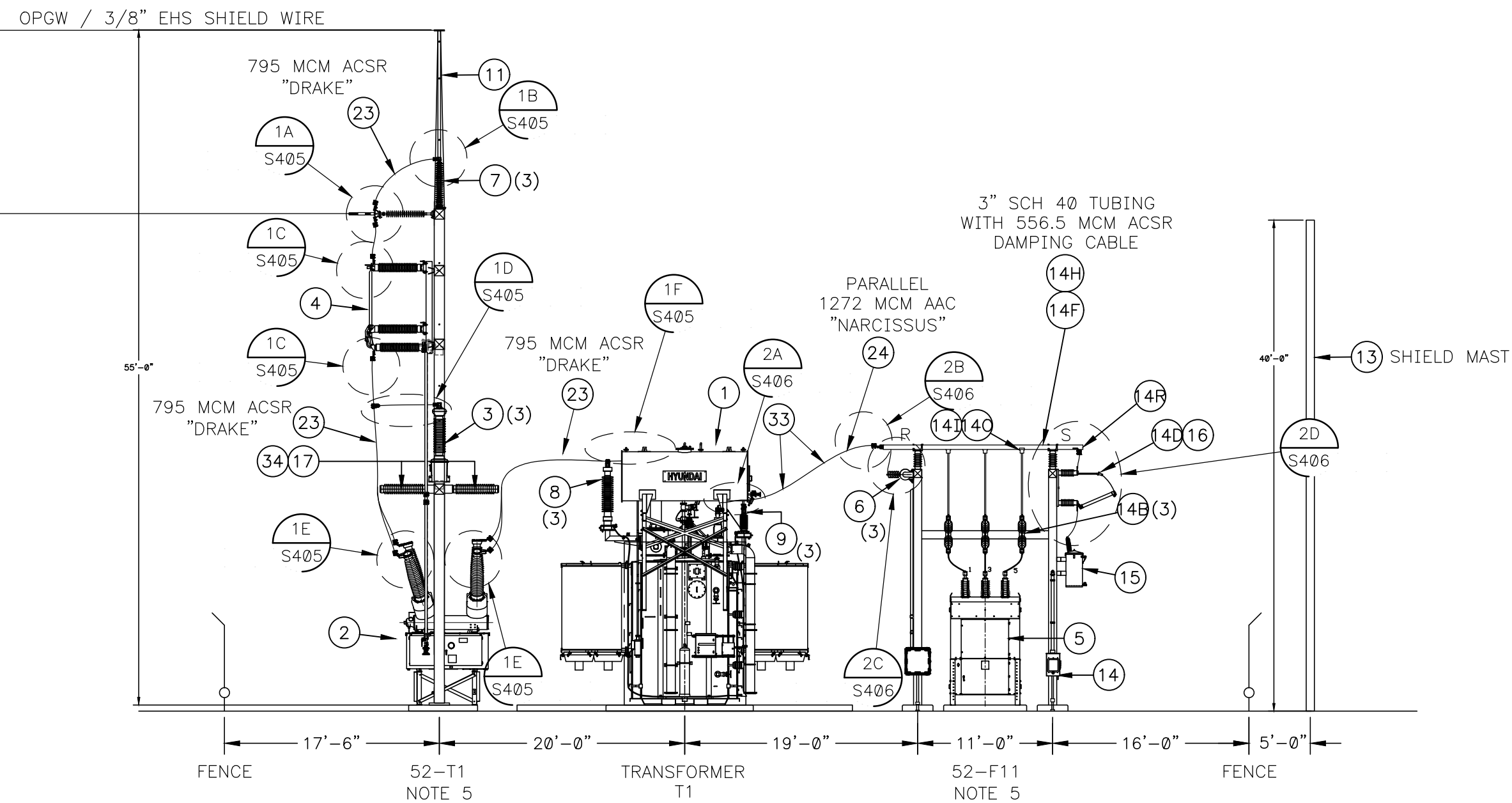

A SECTION
S401

- NOTES**
1. INSTALL 556.5 KCML ACSR DAMPING CABLE IN 3" SCH 40 AL TUBING RUNS.
 2. 34.5KV CABLE & TERMINATION MATERIALS ARE INCLUDED WITH COLLECTOR MATERIALS.
 3. SEE DRAWINGS S200, S400-1 & S400-2 FOR BILL OF MATERIAL.
 4. SEE DRAWING S401 FOR EQUIPMENT PLAN.
 5. SEE BREAKER GROUND CLEARANCE REQUIREMENTS IN DWG. S305 AND S403.

- LEGEND**
- R RIGID CONNECTION
 - S SLIP CONNECTION
 - E EXPANSION CONNECTION
 - (XX) B.O.M. ITEM NUMBER

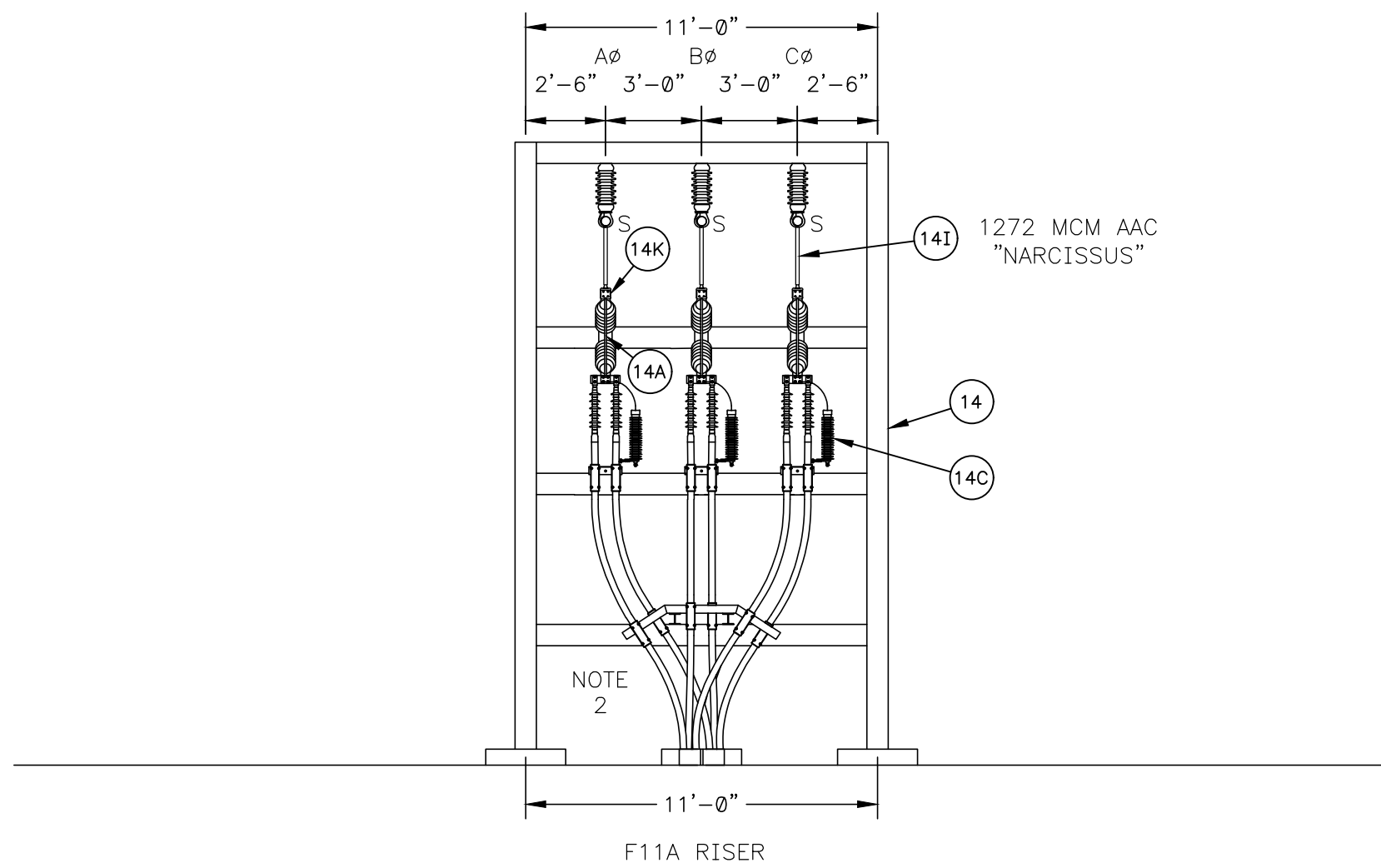

B SECTION
S401

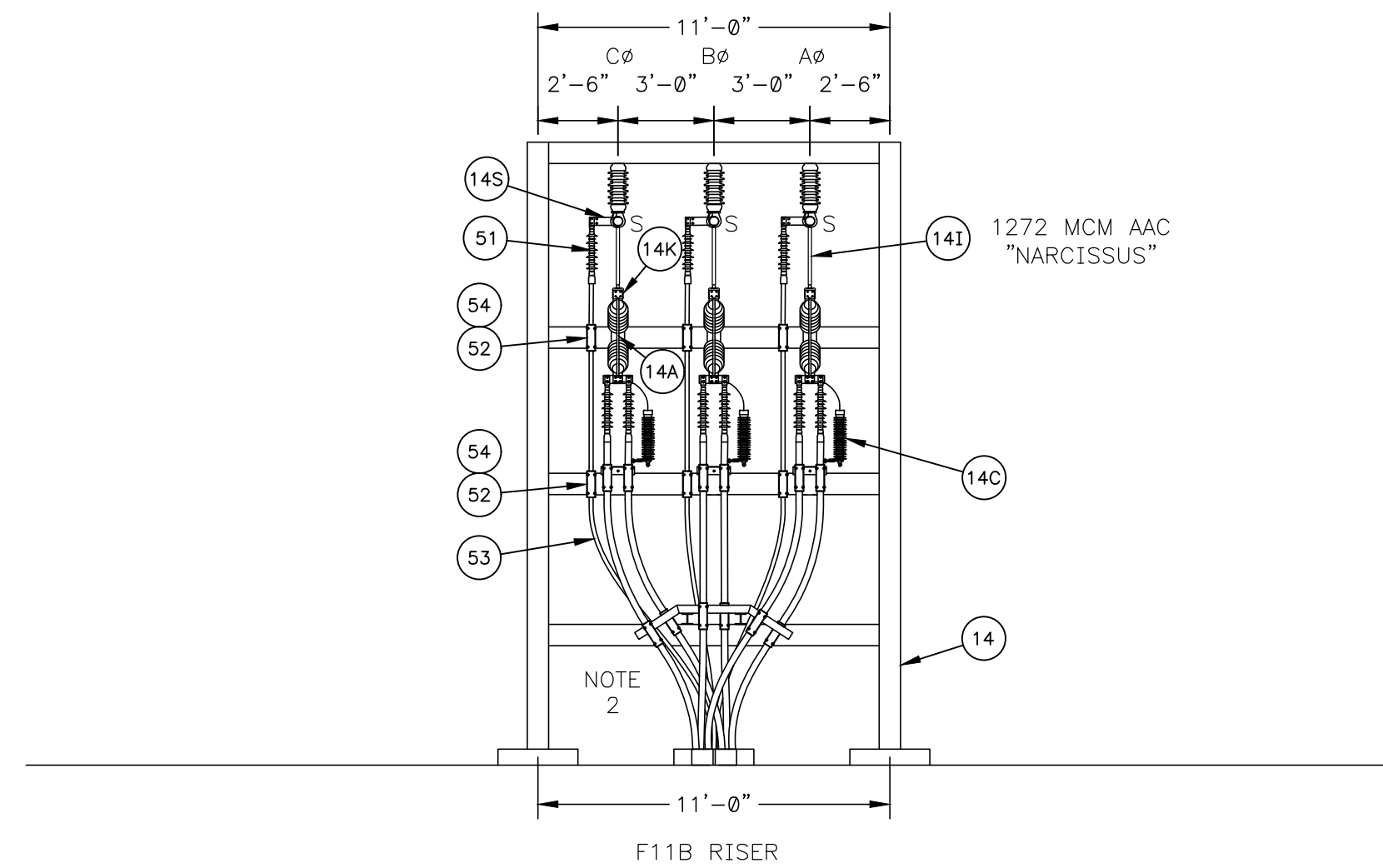

C SECTION
S401

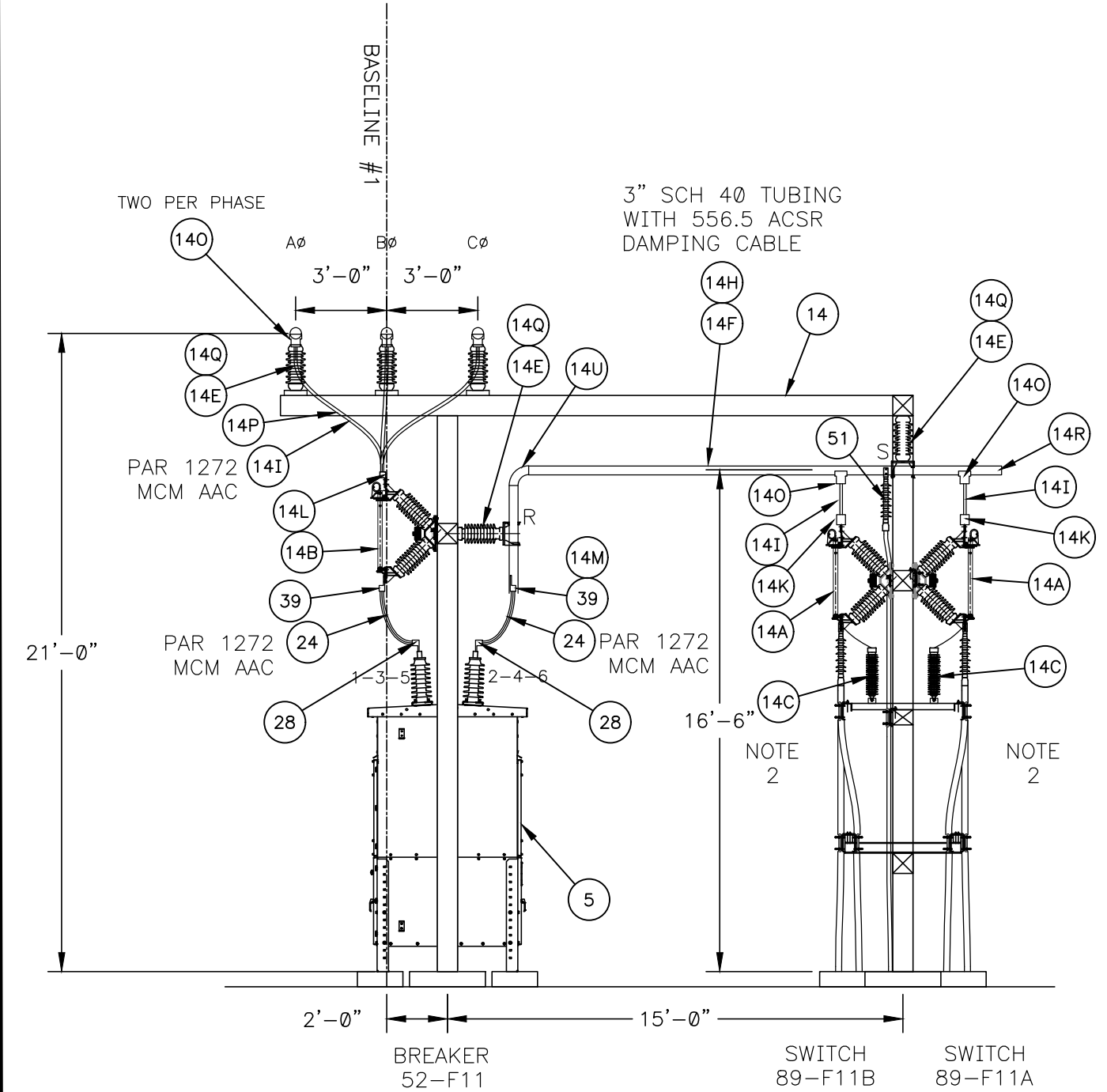

D SECTION
S401

22234

P & E ENGINEERING CO.
POWER SYSTEM ANALYSIS AND DESIGN
245 S. 5th P.O. Box 620 Carlisle, IA 50047
Office: 515-989-3083 FAX: 515-989-3138 peengr@peengr.com

REV	DESCRIPTION	DESIGNED	DFTR	APPR	DATE	INCEPTION
C	UPDATE SUBSTATION NAME	P&E	P&E	JJS	2022-01-14	DATE 2020-08-18
B	REVISED PER NEER COMMENTS	P&E	P&E	JJS	2021-11-12	DESIGN P&E
A	ORIGINAL DESIGN	P&E	P&E	JJS	2020-08-26	DFTR P&E APPR JJS

ISSUED FOR PERMIT

BUFFALO RIDGE WIND, LLC
SECTIONS A-A, B-B, C-C, & D-D

SCALE:
AS NOTED

REV
C
DWG NO
E9614-S402

Representative Photograph of Collector Substation



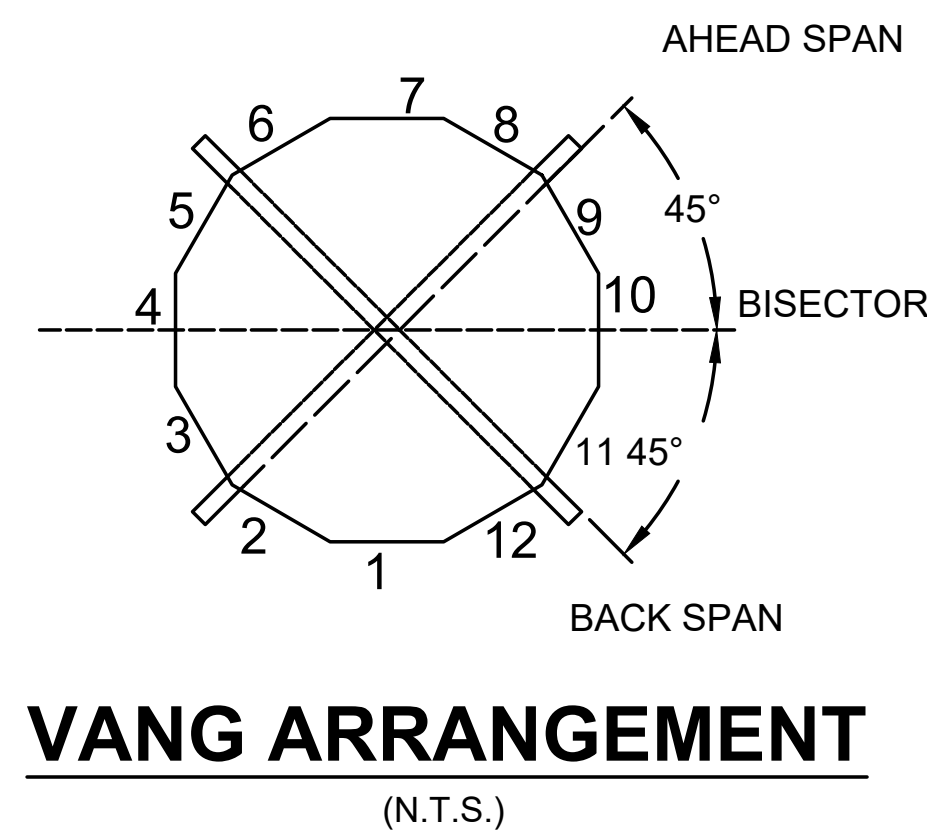
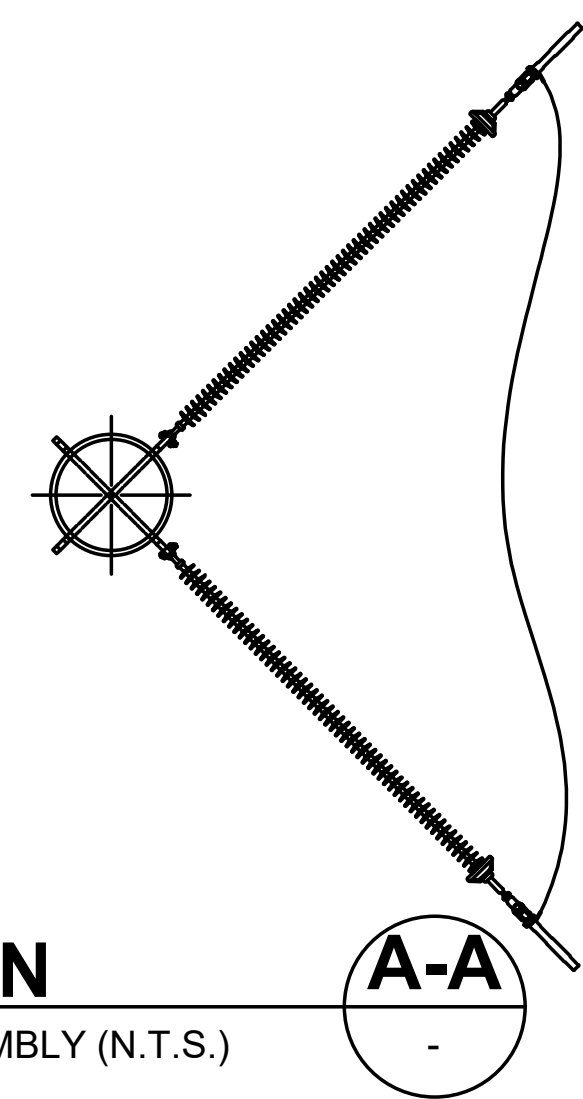
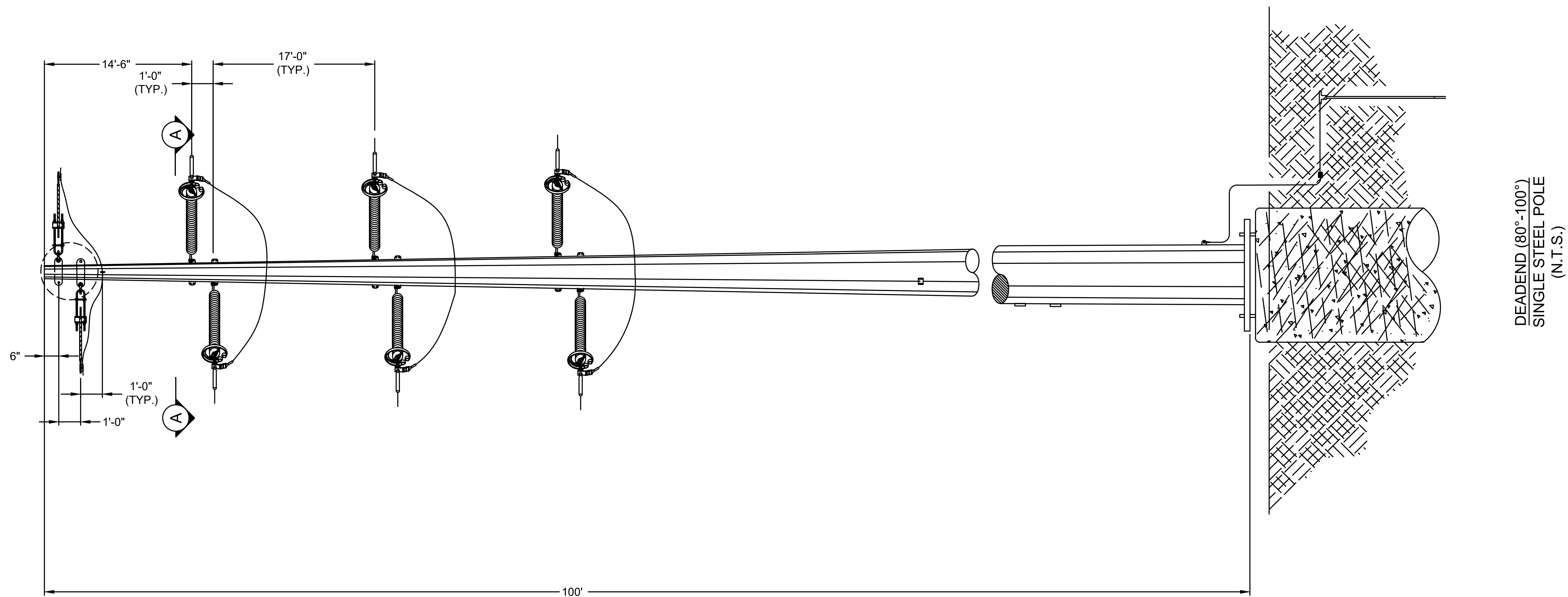

SECTION
JUMPER ASSEMBLY (N.T.S.)

VANG ARRANGEMENT
(N.T.S.)

NO	DATE	REVISIONS AND RECORD OF ISSUE	DRWN	REV'D	APPR	COMP	APPD:	TRK	DATE:	11/15/2021
B	11/24/2021	PRELIMINARY - ISSUED FOR REVIEW	NJT	TRK	TRK	S&L	PREP:	NJT	CHKD:	TRK
A	11/15/2021	PRELIMINARY - ISSUED FOR REVIEW	NJT	TRK	TRK	S&L				

SCALE:
NONE

CONTRACTOR/INSTALLER SHALL TAKE ALL APPROPRIATE PRECAUTIONS TO ENSURE THE SAFETY OF ALL PEOPLE LOCATED ON THE WORK SITE, INCLUDING CONTRACTOR'S /INSTALLER'S PERSONNEL (OR THAT OF IT'S SUB-CONTRACTOR(S)) PERFORMING THE WORK.

ANY MODIFICATION OR ADDITION TO THIS DRAWING BY ANY ORGANIZATION OTHER THAN SARGENT & LUNDY IS NOT THE RESPONSIBILITY OF SARGENT & LUNDY.



BUFFALO RIDGE WIND
STRUCTURE STANDARDS
SINGLE CIRCUIT SELF-SUPPORT
TYPICAL DEADEND (80°-100°) FRAMING

SK-DE-CAISSON