



P.O. Box 13200 • Grand Forks, ND 58208-3200
1822 Mill Road • Grand Forks, ND 58203
November 24, 2015

Phone (701) 795-4000
www.minnkota.com

VIA ELECTRONIC FILING

Daniel P. Wolf Executive Secretary
Minnesota Public Utilities Commission
121 7th Place East, Suite 350
St. Paul, MN 55101

Re: Minnkota Power Cooperative, Inc.'s Application for a Route Permit – Alternative Permitting Process
Clearbrook–Clearbrook West 115 kV HVTL Project
PUC Docket No. ET6/TL-14-665

Dear Mr. Wolf:

Please find the Minnkota Power Cooperative, Inc. ("Applicant") Route Permit Application ("Application") for a 5.3 mile long 115 kV high voltage transmission line located in Leon and Pine Lake Townships, Clearwater County, MN "Clearbrook-Clearbrook West", and a new 115/41.6 kV substation will in Pine Lake township. The Application details the Applicants' proposed location of the Clearbrook-Clearbrook West 115 kV HVTL project.

The Route Permit Application is submitted under the Alternative Permitting process of Minn. Rules 7850.2800 to 7850.3900 and Minn. Stat. § 216E.04. An electronic copy on CD ROM and 18 paper copies of the Application have been provided to David Birkholz of the Department of Commerce, Energy Environmental Review and Analysis.

Minnkota has deposited with the Department of Commerce, \$10,000.00 for processing the route permit application (as required by Minn. Rules 7850.1800 and Minn. Stat. § 216E.18).

Should you any questions with respect to the filing, please contact me at 701-795-4221. Thank you for your attention to this project.

Yours truly,

A handwritten signature in cursive script, appearing to read "John T. Graves".

John T. Graves, P.E.
Environmental Manager

C: Service List
David Birkholz, DOC
Jay Bushy
✓ Louise L. Segroves - Barr Engr.

MINNKOTA POWER COOPERATIVE, INC.

**APPLICATION TO THE
MINNESOTA PUBLIC UTILITIES COMMISSION
FOR A
ROUTE PERMIT**

**CLEARBROOK - CLEARBROOK WEST 115 KV HVTL PROJECT
115 KV TRANSMISSION LINE
AND NEW SUBSTATION**

**Alternative Permitting Process
PUC Docket No. 14-665**

November 20, 2015

This page is intentionally blank.

TABLE OF CONTENTS

| | | |
|-------|---|----|
| 1.0 | Executive Summary..... | 1 |
| 1.1 | Proposal Summary | 1 |
| 1.2 | Completeness Checklist | 4 |
| 2.0 | Introduction | 7 |
| 2.1 | Statement of Ownership..... | 7 |
| 2.2 | Requested Action..... | 7 |
| 2.3 | Permittee | 8 |
| 2.4 | Certificate of Need | 8 |
| 2.5 | Route Permit, Alternative Permitting Process | 8 |
| 2.6 | Notice to the Commission..... | 8 |
| 3.0 | Proposed Project Information | 9 |
| 3.1 | Proposed Project Location | 9 |
| 3.2 | Project Proposal..... | 9 |
| 3.3 | Need for Project..... | 10 |
| 3.4 | Project Schedule | 10 |
| 3.5 | Project Costs | 10 |
| 4.0 | Facility Description and Route Selection Rationale | 12 |
| 4.1 | Transmission Line Description | 12 |
| 4.2 | Route Width and Alignment Selection Process | 12 |
| 4.2.1 | Route Width..... | 12 |
| 4.2.2 | Route Selection Process..... | 12 |
| 4.3 | Alternate Route Segments Considered and Rejected..... | 13 |
| 4.4 | Associated Facilities and Substation Modifications..... | 13 |
| 4.5 | Design Options to Accommodate Future Expansion | 13 |
| 5.0 | Engineering Design, Construction and ROW Acquisition..... | 14 |
| 5.1 | Structures, ROW, Construction and Maintenance..... | 14 |
| 5.1.1 | Transmission Structures..... | 14 |
| 5.1.2 | Right-of-Way Width | 16 |
| 5.1.3 | Right-of-Way Evaluation and Acquisition | 17 |
| 5.1.4 | Construction Procedures | 19 |
| 5.1.5 | Restoration Procedures | 20 |
| 5.1.6 | Maintenance Procedures..... | 21 |
| 5.2 | Electric and Magnetic Fields | 22 |
| 5.2.1 | Health and Environmental Effects | 22 |
| 5.2.2 | Electric Fields | 24 |
| 5.2.3 | Magnetic Fields | 26 |
| 5.2.4 | Stray Voltage | 28 |
| 5.2.5 | Farm Operations, Vehicle Use and Metal Buildings Near Power Line..... | 28 |
| 6.0 | Environmental Information | 29 |
| 6.1 | Environmental Setting | 29 |
| 6.2 | Human Settlement..... | 29 |
| 6.2.1 | Public Health and Safety | 29 |
| 6.2.2 | Residential and Non-Residential Land Use | 30 |

| | | |
|--------|---|----|
| 6.2.3 | Displacement | 31 |
| 6.2.4 | Noise | 31 |
| 6.2.5 | Television and Radio Interference | 34 |
| 6.2.6 | Aesthetics | 34 |
| 6.2.7 | Socioeconomic | 35 |
| 6.2.8 | Cultural Values | 36 |
| 6.2.9 | Recreation | 37 |
| 6.2.10 | Public Services | 37 |
| 6.2.11 | Utilities | 37 |
| 6.2.12 | Transportation and Traffic | 37 |
| 6.3 | Land Based Economics | 38 |
| 6.3.1 | Agriculture | 38 |
| 6.3.2 | Forestry | 39 |
| 6.3.3 | Tourism | 39 |
| 6.3.4 | Mining | 40 |
| 6.4 | Archaeological and Historic Resources | 40 |
| 6.5 | Natural Environment | 43 |
| 6.5.1 | Air Quality | 43 |
| 6.5.2 | Water Resources | 44 |
| 6.5.3 | Flora | 46 |
| 6.5.4 | Fauna | 47 |
| 6.6 | Rare and Unique Natural Resources | 47 |
| 7.0 | Agency Involvement, Public Participation and Required Permits and Approvals | 50 |
| 7.1 | Project Notices to Agencies, LGUs, and Interested Parties | 50 |
| 7.2 | United States Rural Utilities Service | 50 |
| 7.3 | Identification of Landowners | 51 |
| 7.4 | Required Permits and Approvals | 51 |
| 7.4.1 | Federal Permits | 51 |
| 7.4.2 | State of Minnesota Permits | 52 |
| 7.4.3 | Local Permits | 52 |
| 8.0 | References | 53 |
| 9.0 | Definitions | 54 |
| 10.0 | Acronyms | 58 |

TABLES

Table 1 Completeness Checklist 4
Table 2 Detailed Project Location..... 9
Table 3 Estimated Project Schedule 10
Table 4 Estimated Project Cost..... 11
Table 5 Typical Structure Design Summary 14
Table 6 Calculated Electric Fields (kV/m) for Proposed Transmission Line Design (1 meter above ground) 25
Table 7 Calculated Magnetic Fields (mG) for Proposed 115 kV Transmission Line..... 27
Table 8 Residential and Non-residential Buildings within Various Distances of Proposed Route 30
Table 9 Common Noise Sources and Levels 32
Table 10 Noise Standards by Noise Area Classification (dBA) 32
Table 11 Calculated Audible Noise (dBA) for Proposed Transmission Line Designs 33
Table 12 Population and Economic Characteristics..... 36
Table 13 Prime Farmland within ROW and Routes and Proposed Substation Location 39
Table 14 Identified Archaeological and Historic Resources within 1 ½ Mile of the Proposed Project.. 41
Table 15 Acres of Wetland within Routes/ROW and Proposed Substation Location 45
Table 16 Potential Permits Required 51

FIGURES

Figure 1 Project Overview..... 2
Figure 2 Alternative Routes Evaluated 3
Figure 3 Typical Monopole Horizontal Post Insulator Structure..... 15
Figure 4 Typical Three-Pole Structure..... 16

APPENDICES

Appendix A Applicant’s Notice Letter to Commission of Intent to Use Alternative Permitting Process
Appendix B Project Detail Mapbook
Appendix C Environmental feature and resource maps
Appendix D Landowner List
Appendix E Cultural Resources Review
Appendix F LGU Notice Letter
Appendix G Agency Correspondence

1.0 Executive Summary

1.1 Proposal Summary

Minnkota Power Cooperative, Inc. (Minnkota or the Applicant) submits this application (Application) for a Route Permit to the Minnesota Public Utilities Commission (MPUC or Commission) pursuant to Minnesota Statutes Chapter (Minn. Stat.) 216E and Minnesota Rules (Minn. R.), chapter 7850 (Appendix A). A Route Permit is requested to build an approximately 5.3-mile 115 kilovolt (kV) high voltage transmission line (HVTL) and a new 115/4.16 kV distribution substation (Substation).

The proposed 5.3-mile 115 kV HVTL and Substation (proposed Project) is located in Leon and Pine Lake Townships in Clearwater County, Minnesota. The proposed 5.3-mile 115 kV HVTL will connect via a constructed switch to an existing 115 kV line located on the north side of County Road 74/470th Street and to the east of Pipeline Trail. The existing line originates from the substation located south of County Road 74/470th Street. The proposed Project will extend from the north side of County Road 74/470th Street, approximately one mile southeast of Clearbrook, Minnesota to the proposed Substation to be located approximately two miles southeast of Gonvick, Minnesota.

The proposed Project is needed to address a specific industrial load in the Clearbrook, Minnesota area. An overview of the proposed Project components is provided in Figure 1.

The proposed new 115 kV HVTL will require a 100-foot right-of-way (ROW) (50 feet on either side of the centerline). The Applicant is requesting a variable route width ranging from 200 to 500 feet and a small area of 900 foot route width in Section 23, T149N, R38W to allow adequate flexibility as the Applicant works with landowners and addresses engineering constraints in developing a final alignment for the proposed 115 kV HVTL. Appendix B shows the Applicant's proposed Route including a possible alignment within the route width and the proposed Substation Location. Detailed maps showing resources and environmental features along the proposed Route and near the proposed Substation Location are provided in Appendix C.

Figure 1 Project Overview

Bar: Footer: ArcGIS 10.3_2015-09-15 12:59 File: I:\Projects\231515_1039\Maps\Reports\20150911_Route_Permit_Updates\Figure 1 - Project Overview.mxd User: jll2

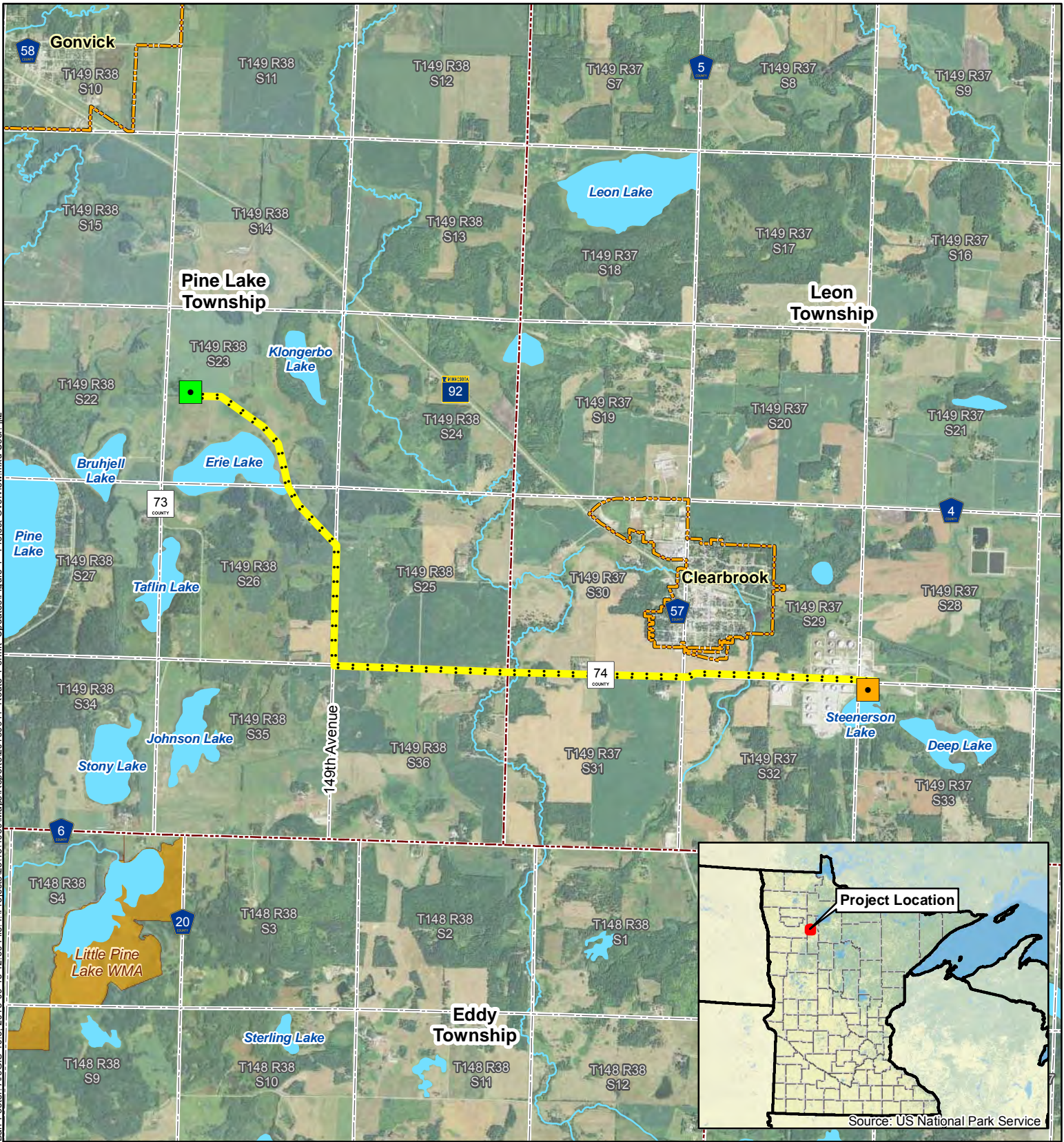

Image Source: 2013 Farm Service Agency

-  Existing Substation Location
-  Proposed Substation Location
-  Anticipated Alignment
-  PWI Watercourse
-  PWI Basin
-  Wildlife Management Area
-  Municipal Boundary
-  PLS Section
-  Township Boundary

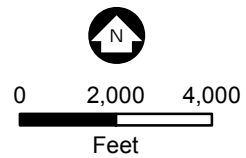

Figure 1

PROJECT OVERVIEW
 Proposed Clearbrook – Clearbrook West
 115 kV HVTL Project
 Minnkota Power
 Clearwater County, MN

Figure 2 Alternative Routes Evaluated

Bar: Footer: ArcGIS 10.3_2015-09-15 12:59 File: I:\Projects\23151039\Map\Reports\20150911_Route_Permit_Updates\Figure 2 - Alternative Routes Considered.mxd User: jlj

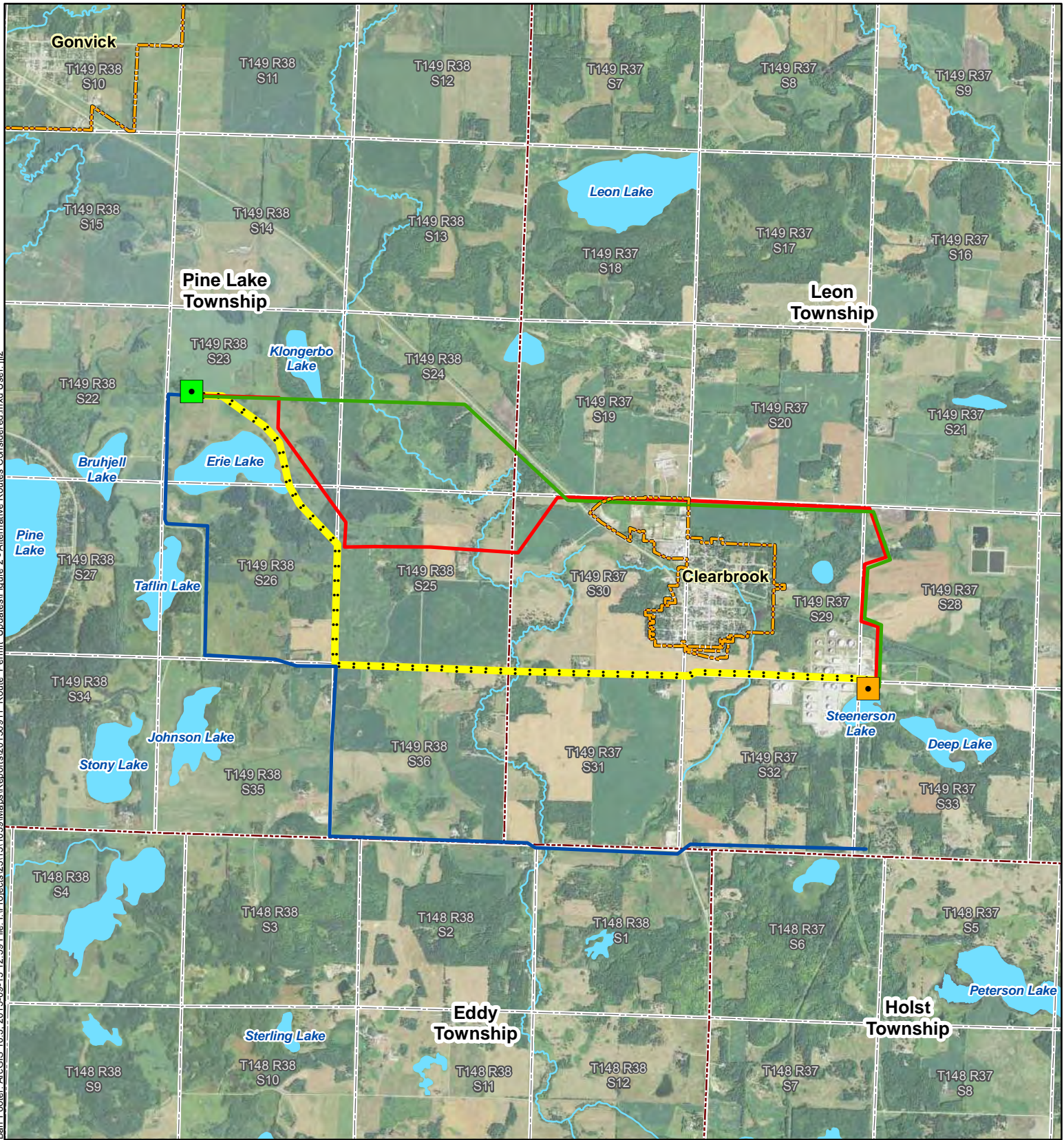

Image Source: 2013 Farm Service Agency

- Existing Substation Location
- Proposed Substation Location
- Anticipated Alignment
- Alternative Route 1
- Alternative Route 2
- Alternative Route 3
- PWI Watercourse
- PWI Basin
- Municipal Boundary
- PLS Section
- Township Boundary

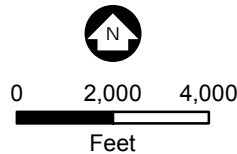

Figure 2

ALTERNATIVE ROUTES CONSIDERED
 Proposed Clearbrook – Clearbrook West
 115 kV HVTL Project
 Minnkota Power
 Clearwater County, MN

This Application is submitted pursuant to the Alternative Permitting Process outlined in Minn. R., parts 7850.2800 to 7850.3900. The proposed 115 kV HVTL and associated facilities is eligible for consideration under the Alternative Permitting Process under Minn. Stat. § 216E.04, subd. 2(3), and Minn. R., parts 7850.2800 to 7850.3900 (see Minn. R., part 7850.2800, subpart 1(C)) because the proposed Project is between 100 and 200 kV. The Applicant respectfully requests that the Commission approve the proposed Route and proposed Substation Location, and authorize a variable route width ranging from 200 to 500 feet and a small area of 900 foot route width in Section 23, T149N, R38W for the 115 kV HVTL as shown in Figure 1 and Appendix B.

1.2 Completeness Checklist

The content requirements for an application with the Commission under the Alternative Permitting Process are identified under Minn. Stat. § 216E.04, subd. 3 and Minnesota Rules, part 3100. The rule requirements are listed in Table 1 with references indicating where the information can be found in this Application.

Table 1 Completeness Checklist

| Authority | Required Information | Route Permit Application Section |
|--|--|----------------------------------|
| Minn. R., part 7850.2800, subparts 1(C) and (D) | Subpart 1. Eligible Projects | |
| | An applicant for a site permit or a Route Permit for one of the following projects may elect to follow the procedures of parts 7850.2800 to 7850.3900 instead of the full permitting procedures in part 7850.1700 to 7850.2700: (C) for HVTLs of between 100 and 200 kV; (D) HVTLs in excess of 200 kV and less than five miles in length. | 2.5 |
| Minn. R., part 7850.2800, subpart 2 | Subpart 2. Notice to Commission | |
| | An applicant for a permit for one of the qualifying projects in subpart 1, who intends to follow the procedures of parts 7850.2800 to 7850.3700, shall notify the PUC of such intent, in writing, at least 10 days before submitting an application for the projects. | 2.6 and Appendix A |
| Minn. R., part 7850.3100 | Contents of Application (alternative permitting process) | |
| | The applicant shall include in the application the same information required in part 7850.1900, except the applicant need not propose any alternative sites or routes to the preferred site or route. If the applicant has rejected alternative sites or routes, the applicant shall include in the application the identity of the rejected sites or routes and an explanation of the reasons for rejecting them. | 4.3 |

| Authority | Required Information | Route Permit Application Section |
|--|---|---|
| Minn. R., part 7850.1900, subpart 2 (applicable per Minn. R., part 7850.3100) | Route Permit for HVTL | |
| A. | A statement of proposed ownership of the facility at the time of filing the application and after commercial operation | 2.1 |
| B. | The precise name of any person or organization to be initially named as permittee or permittees and the name of any other person to whom the Route Permit may be transferred if transfer of the Route Permit is contemplated. | 2.3 |
| C. | At least two proposed routes for the proposed HVTLs and identification of the preferred route and the reasons for the preference. | Not applicable, per Minn. R., part 7850.3100 However, see 4.3. |
| D. | A description of the proposed HVTL and all associated facilities including the size and type of the HVTL. | 3.2, 4.1, 4.4, 5.1.1 |
| E. | The environmental information required under part 7850.1900, subpart 3 | Section 6.0 see Minn. R., part 7850.1900, subpart 3 (A) - (H) |
| F. | Identification of land uses and environmental conditions along the proposed routes. | Section 6.0 |
| G. | The names of each owner whose property is within any of the proposed routes for the HVTL. | Appendix D |
| H. | United States Geological Survey topographical maps or other maps acceptable to the chair showing the entire length of the HVTL on all proposed routes. | Appendix C |
| I. | Identification of existing utility and public ROWs along or parallel to the proposed routes that have the potential to share ROW, the land used by a public utility (as for a transmission line), with the proposed line. | 4.2.2, 5.1.3 |
| J. | The engineering and operational design concepts for the proposed HVTL, including information on the electric and magnetic fields of the transmission line. | Section 5.0 |
| K. | Cost analysis of each route, including the costs of constructing, operating, and maintaining the HVTL that are dependent on design and route. | 3.5, 5.1.6 |
| L. | A description of possible design options to accommodate expansion of the HVTL in the future. | 4.5 |
| M. | The procedures and practices proposed for the acquisition and restoration of the ROW, construction, and maintenance of the HVTL. | 5.1.3-5.1.5 |
| N. | A listing and brief description of federal, state, and local permits that may be required for the proposed HVTL. | 7.4 |

| Authority | Required Information | Route Permit Application Section |
|--|---|---|
| O. | A copy of the Certificate of Need or the certified HVTL list containing the proposed HVTL or documentation that an application for a Certificate of Need has been submitted or is not required. | 2.4 Not applicable, per Minn. Stat. § 216B.2421, subd. 2(3) and 216B.243 |
| Minn. R., part 7850.1900, subpart 3 | Environmental Information | |
| A. | A description of the environmental setting for each site or route. | 6.1 |
| B. | A description of the effects of construction and operation of the facility on human settlement, including, but not limited to, public health and safety, displacement, noise, aesthetics, socioeconomic impacts, cultural values, recreation and public services. | 6.2 |
| C. | A description of the effects of the facility on land-based economies, including but not limited to, agriculture, forestry, tourism, and mining. | 6.3 |
| D. | A description of the effects of the facility on archaeological and historic resources. | 6.4 |
| E. | A description of the effects of the facility on the natural environment, including effects on air and water quality resources and flora and fauna. | 6.5 |
| F. | A description of the effects of the facility on rare and unique natural resources. | 6.6 |
| G. | Identification of human and natural environmental effects that cannot be avoided if the facility is approved at a specific site or route. | Section 6.0 |
| H. | A description of measures that might be implemented to mitigate the potential human and environmental impacts identified in items A to G and the estimated costs of such mitigation measures. | Section 6.0 |

2.0 Introduction

2.1 Statement of Ownership

The proposed 115 kV HVTL and associated facilities will be constructed, owned and operated by Minnkota Power Cooperative, Inc. (Minnkota). Minnkota is a regional generation and transmission cooperative serving 11 member-owner distribution cooperatives. Minnkota's service area of 34,500 square miles is located in eastern North Dakota and northwestern Minnesota. The proposed Project will be located in Clearwater-Polk Electric Cooperative, Inc.'s service area and will connect to an existing 115 kV transmission line. Clearwater-Polk Electric is a distribution cooperative and member-owner of Minnkota.

2.2 Requested Action

This Application is submitted under the Alternative Permitting Process under Minn. Stat. § 216E.04, subd. 2(3) and Minn. R., parts 7850.2800 to 7850.3900 (see Minn. R., part 7850.2800, subpart 1(C)). While the rules do not require consideration of alternate routes in the Application (see Minn. R., part 7850.3100), the Applicant's evaluation of alternatives during the development of the proposed Route and proposed Substation Location is contained in this Application (Section 4.3 and Figure 2).

For reasons identified in subsequent sections of this Application, the Applicant prefers the proposed Route for constructing the proposed 115 kV HVTL and the proposed Substation Location for construction of the new 115/4.16 kV substation (Appendix B). The Applicant respectfully requests that the Commission approve the proposed Route and proposed Substation Location, and authorize a route width ranging from 200 to 500 feet and a small area of 900 foot route width in Section 23, T149N, R38W to allow adequate flexibility as the Applicant works with landowners and addresses engineering constraints in developing a final alignment for the proposed 115 kV HVTL.

This Application demonstrates that construction of the proposed Project along the proposed Route and proposed Substation Location will comply with the applicable standards and criteria set out in Minn. Stat. § 216E.03, subd. 7 and Minn. R., part 7850.4100. The proposed Project will support the State's goals to conserve resources, minimize environmental and human settlement impacts and land use conflicts, and ensure the State's electric energy security through the construction of efficient, cost-effective infrastructure.

2.3 Permittee

The permittee for the proposed Project is:

Permittee: Minnkota Power Cooperative, Inc.

Contact: John T Graves
Environmental Manager

Address: PO Box 13200
1822 Mill Road
Grand Forks, ND 58208-3200

Phone: (701) 795-4221

E-mail: jgraves@minnkota.com

2.4 Certificate of Need

Minn. Stat. § 216B.243, subd. 2 states that “no large energy facility” shall be sited or constructed in Minnesota without the issuance of a Certificate of Need by the Commission. The proposed Project does not meet the definition of a “large energy facility” under Minn. Stat. § 216B.2421. While the proposed Project is a HVTL with a capacity of 100 kV or more, it is not more than 10 miles long in Minnesota and it does not cross a state line (Minn. Stat. § 216B.2421 subd. 2(3)). Therefore, a Certificate of Need is not required for the proposed Project.

2.5 Route Permit, Alternative Permitting Process

The Minnesota Power Plant Siting Act (PPSA) states that no person may construct an HVTL without a Route Permit from the Commission (Minn. Stat. § 216E.03, subd. 2). Under the PPSA, an HVTL is considered to be a transmission line that is 100 kV or more and is greater than 1,500 feet in length (Minn. Stat. § 216E.01, subd. 4). The proposed Project is capable of operating at more than 100 kV and is greater than 1,500 feet in length and, therefore, a Route Permit is required from the Commission prior to construction. The proposed Project qualifies for review under the Alternative Permitting Process authorized by Minn. Stat. § 216E.04, subd. 2(3) and Minn. R., part 7850.2800, subpart 1(C). Accordingly, the Applicant is following the provisions of the Alternative Permitting Process outlined in Minn. R., parts 7850.2800 to 7850.3900 for this proposed Project.

2.6 Notice to the Commission

The Applicant notified the Commission on August 5, 2014, by letter sent via the U.S. Postal Service and e-filed that the Applicant intends to use the Alternative Permitting Process for the proposed Project. This letter complies with the requirement of Minn. R., part 7850.2800, subpart 2, to notify the Commission of this election at least 10 days prior to submitting an application for a Route Permit. A copy of the letter is attached in Appendix A.

3.0 Proposed Project Information

3.1 Proposed Project Location

The proposed Project is located in central Clearwater County, Minnesota, near the city of Clearbrook. Figure 1 shows an overview of the Project area. The proposed Route and the proposed Substation Location are shown in Appendix B. Maps providing an overview of natural resources in the Project area are included in Appendix C. Table 2 identifies the detailed location information for the proposed Project.

Table 2 Detailed Project Location

| Township | Range | Section | County |
|----------|-------|---------|------------|
| 149N | 37W | 33 | Clearwater |
| 149N | 37W | 32 | Clearwater |
| 149N | 37W | 28 | Clearwater |
| 149N | 37W | 29 | Clearwater |
| 149N | 37W | 30 | Clearwater |
| 149N | 37W | 31 | Clearwater |
| 149N | 38W | 35 | Clearwater |
| 149N | 38W | 36 | Clearwater |
| 149N | 38W | 25 | Clearwater |
| 149N | 38W | 26 | Clearwater |
| 149N | 38W | 23 | Clearwater |

3.2 Project Proposal

As shown in Figure 1, the proposed 115 kV HVTL will start in Leon Township by tapping an existing 115 kV line via construction of a 3-way switch and will end in Pine Lake Township at the proposed 115/4.16 kV Substation. The 3-way switch will be constructed by Ottertail Power Company. The proposed 115 kV HVTL will be constructed within a 100-foot wide ROW and the proposed Substation will have a 150-foot by 100-foot footprint.

From its starting point in Leon Township, the proposed HVTL extends west, following existing roadway ROW along County Road 74 for approximately three miles before turning north to follow existing roadway ROW along 149th Avenue for approximately one mile. Where 149th Avenue terminates, the proposed HVTL would extend northwest along a new ROW for approximately one mile before turning west to connect to the proposed Substation Location. Where the proposed Project parallels the south side of County Road 74 (west of Minnesota Highway 92), existing low-voltage distribution lines will be removed and buried by Clearwater-Polk Electric Cooperative.

Additional detail regarding each of these components is provided in Section 4.0.

3.3 Need for Project

North Dakota Pipeline Company, LLC is planning to construct a new pumping station west of Clearbrook, Minnesota, as part of the new Sandpiper Pipeline. North Dakota Pipeline Company, LLC has requested electric service for a pumping station from Clearwater-Polk Electric, a distribution cooperative and member-owner of Minnkota. This new facility is relatively large and is located in a rural area. The proposed Project will require a distribution voltage which is different than the typical distribution voltage for Clearwater-Polk Electric volts. To serve this load, Minnkota will design, procure, and construct approximately 5.3 miles of 115 kV HVTL, a 115 kV line switch to tap an existing line, and an industrial substation suitable to serve the load to be located directly adjacent to the pumping station.

Minnkota commonly utilizes dedicated transmission and substation facilities for large, industrial loads that are constructed in rural areas. The proposed facilities will provide adequate and reliable service in the most cost effective manner.

3.4 Project Schedule

Construction of the proposed Project is expected to begin in the 2nd quarter of 2016, and the Applicant anticipates a 4th quarter 2017 in-service date for the proposed facilities. Table 3 provides an estimated permitting and construction schedule summary for the proposed Project. This schedule is based on information available at the date of this filing and planning assumptions that balance the timing of implementation with the availability of crews, materials, and other practical considerations. This schedule may be revised as further information is developed.

Table 3 Estimated Project Schedule

| Project Task | Date |
|---|------------------------------|
| File Route Permit Application (Application) with the Commission | 3 rd Quarter 2015 |
| Route Permit Review Process Complete | 2 nd Quarter 2016 |
| Begin HVTL and Substation Construction | 2 nd Quarter 2016 |
| In-Service Date | 4 th Quarter 2017 |

3.5 Project Costs

The Applicant estimates that the proposed Project construction will cost approximately \$4.3 million. A breakdown of the estimated proposed Project cost is shown in Table 4.

Table 4 Estimated Project Cost

| Project Item | Cost |
|---------------------------|--------------------|
| 115 kV HVTL facilities | \$1,800,000 |
| New substation | \$2,500,000 |
| Total Project Cost | \$4,300,000 |

Maintenance costs after construction will be nominal for several years, since the proposed HVTL will be new and there will be minimal initial vegetation management required. Typical annual operating and maintenance costs for 115 kV HVTLs across Minnkota’s system area are on the order of \$2,000 per mile per year. The principal operating and maintenance costs include inspections of the transmission ROW, which are conducted using fixed-wing aircraft and helicopter on a regular basis.

Minnkota performs monthly inspections of substations and associated equipment. Maintenance and repair are performed on an as-needed basis, and therefore the cost varies from substation to substation.

4.0 Facility Description and Route Selection Rationale

4.1 Transmission Line Description

The proposed Project involves building 5.3 miles of new 115 kV HVTL. The proposed Project will primarily use wood monopole structures. However, a three-pole structure will be utilized where the proposed line crosses a wetland and immediately makes a turn (Appendix B, Figures B-8 and B-9). As shown in Figure 1, the proposed Project will start in Leon Township by tapping an existing 115 kV line via a 3-way line switch and the proposed Project will end in Pine Lake Township at the proposed 115/4.16 kV Substation Location. The 3-way switch will be constructed by Ottertail Power Company.

From its starting point in Leon Township, the proposed HVTL extends west, following existing roadway ROW and existing distribution line ROW along County Road 74 for approximately three miles before turning north to follow existing roadway ROW along 149th Avenue for approximately one mile. Where 149th Avenue terminates, the proposed HVTL would extend northwest along a new ROW for approximately one mile before turning west to connect to the proposed Substation Location. Where the proposed Project parallels County Road 74, existing low-voltage distribution lines will be removed and buried by Clearwater-Polk Electric Cooperative. No structures will be located in wetlands. Additionally, all spans that cross wetlands will have bird flight diverters installed.

4.2 Route Width and Alignment Selection Process

4.2.1 Route Width

The PPSA directs the Commission to locate transmission lines in a manner that “minimize[s] adverse human and environmental impact while ensuring continuing electric power system reliability and integrity and ensuring their electric needs are met and fulfilled in an orderly and timely fashion” (Minn. Stat. § 216E.02, subd. 1). The PPSA also authorizes the Commission to meet its routing responsibility by designating a “route” for a new transmission line when it issues a Route Permit. The route may have “a variable width of up to 1.25 miles” within which the ROW for the facilities can be located (Minn. Stat. § 216E.01, subd. 8).

The proposed new 115 kV HVTL will require a 100-foot ROW (50 feet on either side of the proposed centerline). The Applicant is requesting a variable route width ranging from 200 to 500 feet and a small area of 900 foot route width in Section 23, T149N, R38W to allow adequate flexibility as the Applicant works with landowners and addresses engineering constraints in developing a final alignment for the proposed 115 kV HVTL. Appendix B shows the Applicant’s proposed Route including currently preferred alignment within the proposed Route.

4.2.2 Route Selection Process

The Applicant developed the proposed Route with consideration of the statutory and rule criteria set forth in the PPSA and Minn. R., part 7850.4100 as well as to the State of Minnesota’s practice of non-proliferation of new infrastructure corridors. The Applicant also worked to coordinate with landowners

to identify viable routes. In addition, the Applicant assessed existing utility and public ROWs to identify opportunities for ROW sharing and constraints for alignment and pole placement. Appendix B shows existing electric infrastructure in the Project area.

Early in the planning process, the Applicant assessed the general area surrounding the proposed Project to identify significant routing issues that might arise and to evaluate environmental resources in the vicinity of the proposed Project. A team of siting, ROW, planning, environmental, ecological, and engineering personnel worked together to develop a proposed Route that minimizes overall impacts of the proposed Project while still fulfilling the Project purpose of providing service to the industrial customer's load in the Clearbrook area.

4.3 Alternate Route Segments Considered and Rejected

The range of potential routes considered by the Applicant for the proposed Project was constrained by a need to connect to existing infrastructure and the small geographic area of the proposed Project. However, in addition to the proposed Route the Applicant identified and evaluated three alternative routes to tap the existing 115 kV line in Leon Township and connect to the proposed 115/4.16 kV Substation in Pine Lake Township (Figure 2). For the routes shown in Figure 2, the Applicant performed a desktop evaluation of potential impacts to humans and the natural environment using available Geographic Information System (GIS) data. To supplement this desktop assessment, the Applicant completed field reviews of each of the routes. The analysis of alternative routes relied on several key indicators including proximity to homes, potential for corridor sharing, total line length, cover type, productive agricultural land use, and wetland area within the potential ROW to assess potential impacts in the factor areas identified in Minnesota Rules, part 7850.4100. Based on this review, the Applicant determined that the proposed Route minimizes both human and natural resource impacts by minimizing proximity to homes, maximizing corridor sharing with existing electrical infrastructure, minimizing forested areas and wetland areas within the potential ROW, and minimizing overall route length.

4.4 Associated Facilities and Substation Modifications

The proposed 115/4.16 kV Substation will have a 20 mega volt ampere (MVA) transformer; a 115 kV disconnect, fusing and circuit breaker; a low side bus, metering equipment, station service, and a disconnect. The 115 kV HVTL will be constructed within a 100-foot wide ROW and the proposed Substation will have a 150-foot by 100-foot footprint. Appendix B shows the proposed Substation location and dimensions.

4.5 Design Options to Accommodate Future Expansion

The proposed facilities are designed with enough capacity to meet current and future needs of the industrial customer.

5.0 Engineering Design, Construction and ROW Acquisition

5.1 Structures, ROW, Construction and Maintenance

5.1.1 Transmission Structures

The 115 kV HVTL will primarily be carried on single pole, wood or steel poles with horizontal post or horizontal brace insulators and a single shield wire. Figure 3 shows typical structure design. The proposed poles will be self-supporting (un-guyed) and will be directly embedded. The structures will have an average height of 65 feet with a 300-foot to 325-foot span between structures. However, where it is necessary to cross wetlands, guyed three pole with cross-arm structures may be utilized (Figure 4). Table 5 provides a general summary of typical structure design for the single pole structures included in the proposed Project.

Table 5 Typical Structure Design Summary

| Line Type | Structure Type | Structure Material | Typical ROW Width (feet) | Approximate Structure Height (feet) | Structure Base Diameter (inches) | Span Between Structures (feet) |
|--------------------------|---|--------------------|--------------------------|-------------------------------------|----------------------------------|--------------------------------|
| Single Circuit 115 kV | Monopole (horizontal post) | Wood or Steel | 100 | 65 (average) 75 (maximum) | 24 | 300-325 |
| | Three pole guyed (cross arm structures) | Wood or Steel | 100 | 95 | 20 | 900 |

The proposed Project will be designed to meet or surpass relevant local, state and national codes including the National Electric Safety Code (NESC), Rural Utilities Service (RUS)-US Department of Agriculture and Minnesota standards. Appropriate standards will be met for construction and installation, and applicable safety procedures will be followed during and after installation.

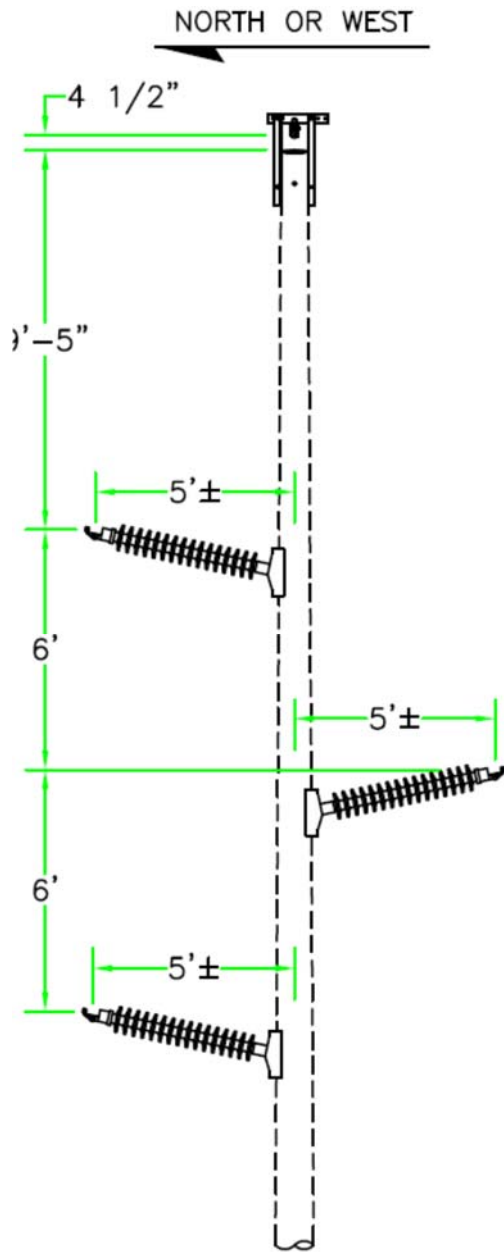

Figure 3 Typical Monopole Horizontal Post Insulator Structure

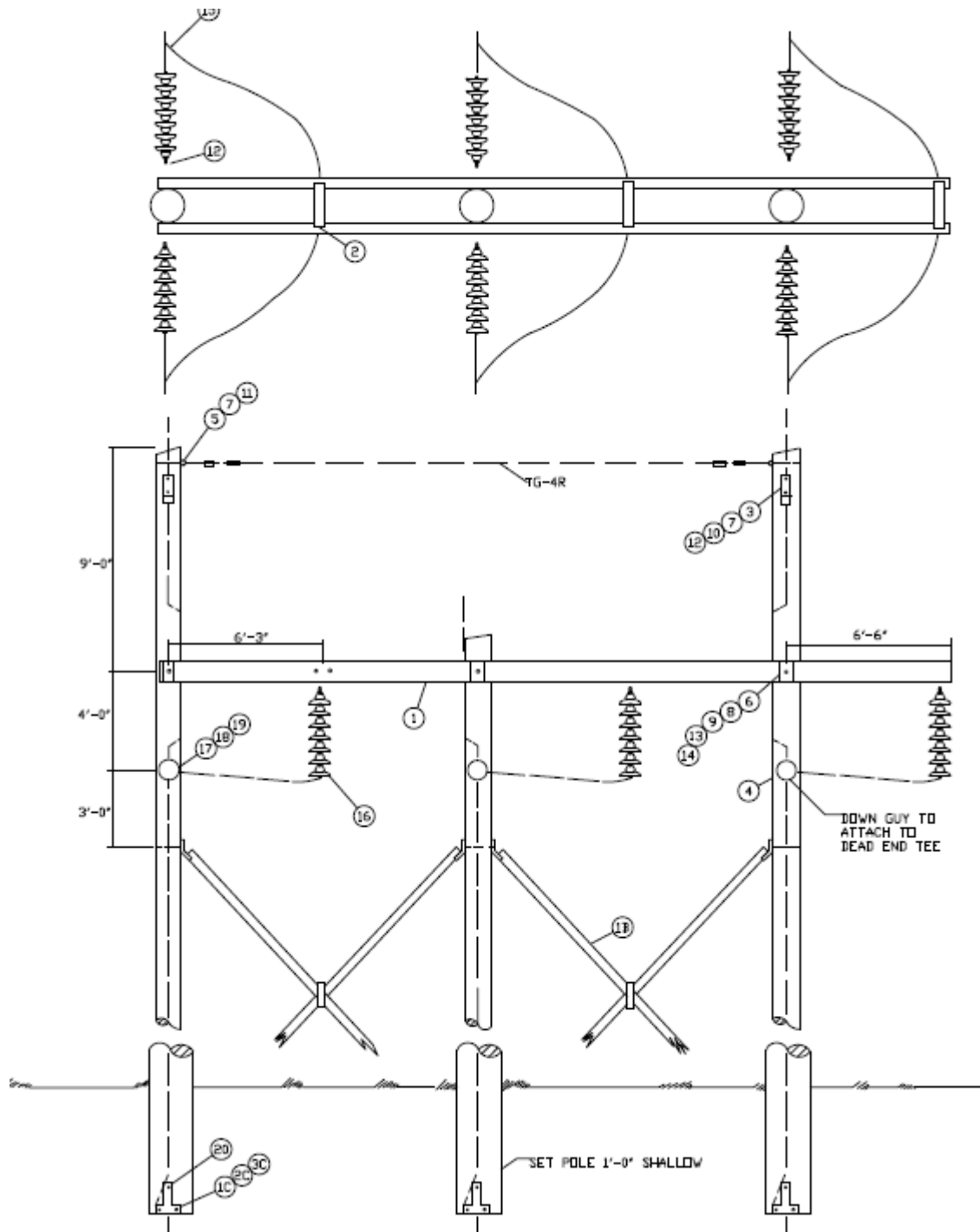

Figure 4 Typical Three-Pole Structure

5.1.2 Right-of-Way Width

The proposed new 115 kV HVTL will require a 100-foot ROW. Where the HVTL is placed cross-country across private land, an easement for the entire ROW will be acquired from the affected landowner(s). When the HVTL parallels other existing infrastructure ROW (e.g., roads, other utilities), an easement of

lesser width may be required as parts of the ROW of the existing infrastructure can often be shared with the ROW needed for the HVTL. When paralleling existing ROW, Minnkota's typical practice is to place poles on adjacent private property, a few feet away from the existing ROW. With this pole placement, the transmission line shares a portion of the existing ROW, thereby reducing the size of the easement required from the private landowner. For the portion of the proposed Project that runs parallel to County Road 74, the proposed HVTL will share ROW with existing Clearwater-Polk Electric Cooperative low-voltage distribution lines which will be removed and buried by Clearwater-Polk Electric Cooperative (Appendix B, Figure B-3 through B-6).

5.1.3 Right-of-Way Evaluation and Acquisition

The proposed Project will require approximately 5.3 miles of new ROW for the proposed 115kV HVTL. The proposed Substation will require a 150-foot by 100-foot plot within a parcel.

For transmission lines, utilities typically acquire easement rights across the parcels to accommodate the facilities, including transmission lines and structures. The ROW acquisition process begins early in the detailed design process. The evaluation and acquisition process includes examining titles, contacting owners, surveying, preparing documents and purchasing the ROW easement. Each of these activities, particularly as it applies to easements for transmission line facilities, is described in more detail below.

The first step in the ROW process is to identify all persons and entities that may have a legal interest in the real estate upon which the facilities will be built. To compile this list, a ROW agent or other person engaged by Minnkota completes a public records search of all land involved in the proposed Project. A title report is then developed for each parcel to determine the legal description of the property and the owner(s) of record and to gather information about easements, liens, restrictions, encumbrances and other conditions of record.

The next step in the acquisition process is to evaluate the specific parcel. After owners are identified, a ROW representative personally contacts each property owner or the property owner's representative. The ROW agent describes the need for the transmission facilities and how the specific project may affect each parcel. The ROW agent also seeks information from the landowner about any specific construction concerns.

The ROW agent may request the owner's permission for survey crews to enter the property and conduct preliminary survey work. The agent may also request permission to take soil borings to assess soil conditions and determine appropriate foundation design. The soil analysis is performed by an experienced geotechnical testing laboratory. Surveys are conducted to locate the existing ROWs, natural features, man-made features and associated elevations for use during the detailed engineering of the line.

During the evaluation process, the location of the proposed HVTL will be staked. The survey crew identifies the future location of each structure or pole on the ground and places a surveyor's stake to

mark the location. The ROW agent shows the landowner the approximate locations where the structure(s) will be located on the property. The ROW agent also delineates the boundaries of the easement area required for safe operation of the HVTL.

Prior to the acquisition of easements of property, land value data will be collected. Based on the impact of the easement or purchase to the market value of each parcel, a fair market value offer will be developed. The ROW agent will contact the property owner to present the offer for the easement and discuss the amount of just compensation to acquire the rights to build, operate, and maintain the transmission facilities within the easement area and for reasonable access to the easement area. The agent will also provide maps of the route or site and maps showing the landowner's parcel. The landowner is allowed a reasonable amount of time to consider the offer and to present any material that the owner believes is relevant to determining the property's value.

In nearly all cases, utilities are able to work with the landowners to address their concerns, and an agreement is reached for the utility's purchase of land rights. The ROW agent prepares all of the documents required to complete each transaction. Some of the documents that may be required include easement, purchase agreement, or contract and deed.

In rare instances, a negotiated settlement cannot be reached and the landowner chooses to have an independent third party determine the value of the rights taken. Such valuation is made through the utility's exercise of the right of eminent domain pursuant to Minn. Stat. Chapter 117. The process of exercising the right of eminent domain is called condemnation.

Before commencing a condemnation proceeding, the ROW agent must obtain at least one appraisal for the property proposed to be acquired and a copy of that appraisal must be provided to the property owner per Minn. Stat. § 117.036, subd. 2(a). The property owner may also obtain another property appraisal and the Company must reimburse the property owner for the cost of the appraisal according to the limits set forth in Minn. Stat. § 117.036, subd. 2(b). The property owner may be reimbursed for reasonable appraisal costs up to \$1,500 for single-family and two-family residential properties, \$1,500 for property with a value of \$10,000 or less, and \$5,000 for other types of properties. In the event of a condemnation, the utility will provide the landowner with a copy of each appraisal it has obtained for the land or property rights.

To start the condemnation process, a utility files a Petition in the district court where the property is located and serves that Petition on all owners of the property. If the court approves the Petition, the court then appoints a three-person condemnation "commission." The three people must understand applicable real estate issues. Once appointed, the commissioners schedule a viewing of the substation location or property over and across which the transmission line easement is to be located. Next, the commission schedules a valuation hearing where the utility and landowners can testify as to the fair market value of the easement or fee. The commission then makes an award as to the value of the property acquired and files it with the court. Each party has 40 days from the filing of the award to

appeal to the district court for a jury trial. In the event of an appeal, the jury hears land value evidence and renders a verdict. At any point in this process, the case can be dismissed if the parties reach a settlement.

Once ROW is acquired and prior to construction, the ROW agent will again contact the owner of each parcel to discuss the construction schedule and construction requirements. To ensure safe construction of the line, special consideration may be needed for fences, crops, or livestock. For example, fences may need to be moved or temporary or permanent gates may need to be installed; crops may need to be harvested early; and livestock may need to be moved. In each case the ROW agent coordinates these actions with the landowner.

5.1.4 Construction Procedures

Minnkota will begin construction after appropriate federal, state, and local approvals are obtained, property and ROWs are acquired, soil conditions are established, and a final design is completed. The precise timing of construction will take into account various requirements that may be in place due to permit conditions, system loading issues, and available workforce.

Minnkota's construction process will follow standard construction and mitigation practices, including best management practices (BMPs) that were developed from experience with past projects. These practices address staging, erecting HVTL structures, and stringing HVTLs. Construction and mitigation practices to minimize impacts will be developed by Minnkota based on the proposed schedule for activities, permit requirements, prohibitions, maintenance guidelines, inspection procedures, terrain, and other factors. In some cases, activities or schedules may be modified to minimize impacts on sensitive environmental features.

HVTL structures are generally designed for installation at existing grades. However, some sloped work areas may need to be graded or filled in order to establish a more level work surface for structure installation. If the landowner permits, it is preferred to leave the leveled areas and working pads in place for use in future maintenance activities, if any. If permission is not obtained, the site is graded back to its original condition to the extent feasible and imported fill is removed.

Typical construction equipment that may be used for the proposed Project includes tree removal equipment, line construction equipment, stringing equipment, and general construction equipment on rubber tires or tracks, as appropriate.

Minnkota may also require staging areas for additional space for storage during construction. These areas have not been identified at this time, but will typically be selected for their location, access, security, and ability to efficiently and safely warehouse supplies. The temporary staging areas outside of the ROW will be obtained by Minnkota through rental agreements.

Minnkota will access the ROW from existing roads or trails that run parallel or perpendicular to the ROW. In some situations, private field roads or trails may be used. Where necessary to accommodate the heavy equipment used in construction, including cranes, cement trucks, and hole-drilling equipment, existing access roads may be upgraded or new roads may be constructed. New access roads may also be constructed when no current access is available or the existing access is inadequate to cross roadway ditches. To the extent possible, Minnkota will coordinate these activities with the affected property owner(s) and/or state and local highway departments as appropriate.

Structure installation first begins by moving structures from the staging areas and delivering them to a staked location. The structures are typically staged within the ROW until the structure is set. Depending on site conditions, structures may be framed in the ground and lifted into place, or the structures may be set first and then bracing and hardware attached.

Most structures will be direct embedded. The area around the structure is then backfilled with crushed rock and/or soil. In lowland areas with poor soil capacity, Minnkota will use galvanized steel culverts to increase structure stability.

Angle structures as well as some tangent structures used to span wetlands may be guyed. Guy wires will be anchored using screw anchors, cross plate anchors, or rock anchors depending on the soil conditions encountered.

After the structures have been assembled, set, and secured, conductors will be installed by establishing stringing setup areas along the route. The conductors will then be pulled with a rope lead that connects to each structure through dollies attached at the insulator locations.

Environmentally sensitive areas (e.g., wetlands) may require special construction techniques, which may vary according to conditions at the time of construction. During construction, impacts on wetland areas will be minimized by Minnkota to the extent possible. Additionally, Minnkota will use construction practices that help prevent soil erosion and will take measures to ensure that equipment fueling and lubricating will occur at a distance from waterways. Additional mitigation measures relating to wetlands are contained in Section 6.5.2.6.

5.1.5 Restoration Procedures

Minnkota will attempt to limit ground disturbance during construction wherever possible. However, disturbance will occur during the normal course of work, which can take several weeks in any one location. As construction is completed (weather permitting), Minnkota will restore disturbed areas to their original condition to the maximum extent practicable. The ROW agents will attempt to contact each property owner after construction is completed to assess if any remaining damage has occurred as a result of the proposed Project. If damage has occurred to crops, fences or the property, Minnkota will fairly reimburse the landowner for the damages sustained that are not repaired or restored by Minnkota or its representatives. In some cases, Minnkota may engage an outside contractor to restore the

damaged property as nearly as possible to its original condition. Portions of vegetation that are disturbed or removed during construction of HVTLs will naturally reestablish to pre-disturbance conditions. Resilient species of common grasses and shrubs typically reestablish with few problems after disturbance. Areas with significant soil compaction and disturbance from construction activities along the proposed Route may require assistance in reestablishing the vegetation stratum and controlling soil erosion. Commonly used methods to control soil erosion and assist in reestablishing vegetation include re-seeding and mulching, erosion control blankets, silt fence installation, and minimizing soil disturbance during construction. To avoid adversely impacting reptile and bird species, Minnkota will not use plastic mesh erosion control materials.

These erosion control and vegetation establishment practices are regularly used in construction projects and are referenced in the construction permit plans. These construction techniques typically minimize long-term impacts that may result from the proposed Project.

The Minnesota Noxious Weed Law (Minn. Stat. § 18.75-18.91) defines a noxious weed as an annual, biennial, or perennial plant that the Commissioner of Agriculture designates to be injurious to the public health, the environment, public roads, crops, livestock, or other property. The Minnesota Department of Agriculture's Noxious & Invasive Weed Program assists local governments and landowners with resources for managing noxious and invasive weeds throughout Minnesota. Minnkota will attempt to limit the spread of noxious and invasive weeds by using only invasive-free mulches, topsoil, and seed mixes. Permanent vegetation will be established in areas disturbed within the construction work area except in actively cultivated areas and standing water wetlands. Seed used will be purchased on a "Pure Live Seed" basis for seeding revegetation areas. The seed tags on the seed sacks will also certify that the seed is "Noxious Weed Free."

Minnkota may use both herbicides and/or mechanical methods to control the spread of noxious weeds. All herbicides used by Minnkota are approved by the Environmental Protection Agency and the State of Minnesota Department of Agriculture. These herbicides are applied by Minnkota or commercial pesticide applicators that are licensed by the Minnesota Department of Agriculture. If during post-construction monitoring of the restored ROW a higher density and cover of noxious weeds on the ROW is noted when compared to adjacent off ROW areas, Minnkota will obtain landowner permission and work to mitigate noxious weed concerns.

5.1.6 Maintenance Procedures

Transmission lines and substations are designed to operate for decades and require only moderate maintenance, particularly in the first few years of operation.

The estimated service life of the proposed HVTL for accounting purposes is approximately 40 years. However, practically speaking, transmission lines are seldom completely retired. Transmission infrastructure has very few mechanical elements and is built to withstand weather extremes that are

normally encountered. With the exception of severe weather such as tornadoes and heavy ice storms, transmission lines rarely fail.

Transmission lines are automatically taken out of service by the operation of protective relaying equipment when a fault is sensed on the system. Such interruptions are usually only momentary. Scheduled maintenance outages are also infrequent. As a result, the average annual availability of transmission infrastructure is very high, in excess of 99 percent.

The principal operating and maintenance cost for transmission facilities is the cost of inspections, which is usually done monthly by air. Annual operating and maintenance costs for transmission lines in Minnesota and surrounding states vary, however, for voltages from 69 kV through 345 kV, past experience shows that costs are approximately \$2,000 per mile. Actual line-specific maintenance costs depend on the setting, the amount of vegetation management necessary, storm damage occurrences, structure types, materials used, and the age of the line.

Substations require a certain amount of maintenance to keep them functioning in accordance with accepted operating parameters and the NESC requirements. Transformers, circuit breakers, batteries, protective relays, and other equipment need to be serviced periodically in accordance with the manufacturer's recommendations. The Substation Location must be kept free of vegetation and adequate drainage must be maintained. Minnkota personnel are typically on site at least once a month and maintenance needs are noted and scheduled for completion.

5.2 Electric and Magnetic Fields

The term EMF refers to electric and magnetic fields that are coupled together, such as in high frequency radiating fields. For the lower frequencies associated with power lines (referred to as “extremely low frequencies” (ELF)), EMF should be separated into electric fields (EFs) and magnetic fields (MFs), measured in kV per meter (kV/m) and milliGauss (mG), respectively. These fields are dependent on the voltage of a transmission line (EFs) and current carried by a transmission line (MFs). The intensity of the EF is proportional to the voltage of the line, and the intensity of the MF is proportional to the current flow through the conductors. Transmission lines operate at a power frequency of 60 hertz (Hz, cycles per second).

5.2.1 Health and Environmental Effects

Considerable research has been conducted in recent decades to determine whether exposure to power-frequency (60 Hz) electric and MFs can cause biological responses and adverse health effects. The multitude of epidemiological and toxicological studies has shown at most a weak association (i.e., no statistically significant association) between EMF exposure and health risks.

In 1999, the National Institute of Environmental Health Sciences (NIEHS) issued its final report on “Health Effects from Exposure to Power-Line Frequency Electric and Magnetic Fields” in response to the Energy Policy Act of 1992. In the report, the NIEHS concluded that the scientific evidence linking EMF

exposures with health risks is weak and that this finding does not warrant aggressive regulatory concern. However, in light of the weak scientific evidence supporting some association between EMF and health effects and the fact that exposure to electricity is common in the United States, the NIEHS stated that passive regulatory action, such as providing public education on reducing exposures, is warranted.

The United States Environmental Protection Agency (USEPA) seems to have come to a similar conclusion about the link between adverse health effects, specifically childhood leukemia, and power-frequency EMF exposure. On its website, the USEPA states:

Many people are concerned about potential adverse health effects. Much of the research about power lines and potential health effects is inconclusive. Despite more than two decades of research to determine whether elevated EMF exposure, principally to magnetic fields, is related to an increased risk of childhood leukemia, there is still no definitive answer. The general scientific consensus is that, thus far, the evidence available is weak and is not sufficient to establish a definitive cause-effect relationship.

Minnesota, California, and Wisconsin have each conducted their own literature reviews or research to examine this issue. In 2002, Minnesota formed an Interagency Working Group to evaluate the research and develop policy recommendations to protect the public health from any potential problems arising from EMF effects associated with HVTLs. The Minnesota Department of Health published the Working Group's findings in "A White Paper on Electric and Magnetic Field (EMF) Policy and Mitigation Options". The Working Group summarized its findings as follows:

Research on the health effects of EMF has been carried out since the 1970's. Epidemiological studies have mixed results – some have shown no statistically significant association between exposure to EMF and health effects, some have shown a weak association. More recently, laboratory studies have failed to show such an association, or to establish a biological mechanism for how magnetic fields may cause cancer. A number of scientific panels convened by national and international health agencies and the United States Congress have reviewed the research carried out to date. Most researchers concluded that there is insufficient evidence to prove an association between EMF and health effects; however many of them also concluded that there is insufficient evidence to prove that EMF exposure is safe.

Based on findings like those of the Working Group and NIEHS, the Commission has consistently found that "there is insufficient evidence to demonstrate a causal relationship between EMF exposure and any adverse human health effects." This conclusion was further justified in the recent Route Permit proceedings for the Brookings County – Hampton 345 kV Project ("Brookings Project"). In the Brookings Project Route Permit proceedings, the Applicants (Great River Energy and Xcel Energy) and one of the intervening parties both provided expert evidence on the potential impacts of electric and MFs on human health. The administrative law judge (ALJ) in that proceeding evaluated written submissions and a day-and-a-half of testimony from the two expert witnesses. The ALJ concluded: "there is no

demonstrated impact on human health and safety that is not adequately addressed by the existing State standards for [EMF] exposure.” The Commission adopted this finding on July 15, 2010.

5.2.2 Electric Fields

While there is no official state or federal standard for transmission line EFs, the Environmental Quality Board (EQB) has developed a standard of a maximum EF limit of 8 kV/m measured at one meter above the ground. The standard was designed to prevent serious hazards from shocks when touching large objects parked under alternative current (AC) transmission lines of 500 kV or greater. Table 6 provides the EFs at maximum conductor voltage for the proposed Project. Maximum conductor voltage is defined as the nominal voltage plus ten percent. This is generally an emergency condition, and Minnkota typically operates its transmission system between 101 percent and 104 percent of nominal voltage under normal conditions.

The unperturbed electric field calculations were performed using transmission line modeling software. For the single circuit 115 kV monopole type structure, the maximum EF at a height of 1.0 meter above ground was calculated to be 0.96 kV/m at the proposed centerline and approximately 0.22 to 0.19 kV/m at the edges of the ROW.

Table 6 Calculated Electric Fields (kV/m) for Proposed Transmission Line Design (1 meter above ground)

| Structure Type | Maximum Operating Voltage (kV) | Distance to Proposed Centerline (feet) | | | | | | | | | | | | |
|--------------------------------|--------------------------------|--|------|------|-----|------|------|------|------|------|-----|------|------|-------|
| | | -300 | -200 | -100 | -75 | -50 | -25 | 0 | 25 | 50 | 75 | 100 | 200 | 300 |
| Single Circuit 115 kV Monopole | 121 | 0.005 | 0.01 | 0.05 | 0.1 | 0.22 | 0.52 | 0.96 | 0.60 | 0.19 | 0.1 | 0.06 | 0.01 | 0.006 |

5.2.3 Magnetic Fields

There are presently no federal or Minnesota regulations pertaining to MF exposure. The EQB and the Commission have recognized that Florida (a 150 mG limit) and New York (a 200 mG limit) are the only two state standards in the country. Recent studies of the health effects from power frequency fields conclude that the evidence of health risk is weak^{[1], [2], [3]}. The general standard is one of prudent avoidance. The Applicant provides information to the public, interested customers and employees so they have an understanding of the MFs associated with the proposed Project.

The MF profiles around the proposed Project are shown in Table 7. MFs were calculated at the conductor's thermal limit based on the design of the HVTL and at the expected peak loading on the lines based on power flow modeling of the transmission system. The peak MF values are calculated at a point directly under the HVTL and where the conductor is closest to the ground. The same method is used to calculate the MF at the edge of the ROW. MF profile data show that MF levels generally decrease rapidly as the distance from the centerline increases.

The estimates of the magnetic fields were performed for maximum cruise loading and maximum emergency line ratings using software based on the Electrical Power Research Institute (EPRI) methodology. The peak MF for this configuration at 1.0 meter above ground was calculated to be 19 mG at the proposed centerline and approximately 5-6 mG at the edges of the ROW under the expected peak loading condition. Peak MF under the conductor thermal limit condition was calculated to be 142 mG at the conductor thermal limits.

Because the actual power flow on a transmission line could potentially vary widely throughout the day depending on electric demand, the actual MF level could also vary widely from hour to hour. In any case, the typical loading of the transmission line will be far below the thermal limit of the line and should remain at or below the expected peak loading for the foreseeable future, resulting in typical MFs well below those indicated in Table 7.

Table 7 Calculated Magnetic Fields (mG) for Proposed 115 kV Transmission Line

| Structure Type | Current (Amps) | Distance to Proposed Centerline (feet) | | | | | | | | | | | | |
|--|----------------|--|------|------|-----|-----|-----|-----|----|----|----|-----|-----|-----|
| | | -300 | -200 | -100 | -75 | -50 | -25 | 0 | 25 | 50 | 75 | 100 | 200 | 300 |
| Magnetic Field Profile at Conductor Thermal Limits | | | | | | | | | | | | | | |
| Single Circuit 115 kV Monopole | 1190 | 1 | 3 | 10 | 17 | 33 | 75 | 142 | 85 | 37 | 18 | 11 | 3 | 1 |
| Magnetic Field Profile at Expected Peak Loading | | | | | | | | | | | | | | |
| Single Circuit 115 kV Monopole | 215 | 0.20 | 0.5 | 2 | 3 | 5 | 11 | 19 | 13 | 6 | 3 | 2 | 0.5 | 0.2 |

5.2.4 Stray Voltage

Stray voltage is a voltage that exists between the neutral wire of the service entrance and grounded objects in buildings, such as barns and milking parlors, and can occur on the electric service entrances to structures from distribution lines, not HVTLs. HVTLs do not, by themselves, create stray voltage because they do not connect to businesses or residences.

5.2.5 Farm Operations, Vehicle Use and Metal Buildings Near Power Line

Insulated electric fences used in livestock operations can pick up an induced charge from transmission lines. Usually, the induced charge will drain off when the charger unit is connected to the fence. When the charger is disconnected either for maintenance or when the fence is being built, shocks may result. Potential shocks can be prevented by using a couple of methods including:

- one or more of the fence insulators can be shorted out to ground with a wire when the charger is disconnected; or
- an electric filter can be installed that grounds out charges induced from a power line while still allowing the charger to be effective.

Farm equipment, passenger vehicles, and trucks may be safely used under and near power lines. The power lines will be designed to meet or exceed minimum clearance requirements over roads, driveways, cultivated fields, and grazing lands specified by the NESC. Recommended clearances within the NESC are designed to accommodate a relative vehicle height of 14 feet.

There is a potential for vehicles under HVTLs to build up an electric charge. If this occurs, the vehicle can be grounded by attaching a grounding strap to the vehicle long enough to touch the earth. Such buildup is a rare event because generally vehicles are effectively grounded through tires. Modern tires provide an electrical path to ground because carbon black, a good conductor of electricity, is added when they are produced. Metal parts of farming equipment are frequently in contact with the ground when plowing or engaging in various other activities. Therefore, vehicles will not normally build up a charge unless they have unusually old tires or are parked on dry rock, plastic or other surfaces that insulate them from the ground.

Buildings are permitted near transmission lines but are generally prohibited within the ROW itself because a structure under a line may interfere with safe operation of the transmission facilities. For example, a fire in a building on the ROW could damage a transmission line. As a result, NESC guidelines establish clear zones for transmission facilities. Metal buildings may have unique issues. For example, metal buildings near power lines of 200 kV or greater must be properly grounded. Any person with questions about a new or existing metal structure can contact the Applicant for further information about proper grounding requirements.

6.0 Environmental Information

This section analyzes potential resource impacts associated with the proposed Project. This section provides a description of the environmental setting, potential impacts, and mitigation measures the Applicant proposes, where appropriate, to minimize the impacts of siting, constructing, and operating the proposed Project. If the proposed HVTL and the proposed Substation were removed in the future, the land could be restored to its prior condition and/or redirected to a different use. The majority of the measures proposed are part of the standard construction process for the Applicant. Unless otherwise identified in the following text, the costs of the mitigation measures proposed are considered nominal.

6.1 Environmental Setting

The proposed Project is located south and west of the City of Clearbrook, Minnesota in central Clearwater County. The proposed Project is primarily located near existing industrial land and agricultural land.

The Project area is located within the Hardwood Hills Subsection of the Minnesota and Northeast Iowa Morainal Section, a section within the biogeographic province known as the Eastern Broadleaf Forest Province under the Ecological Classification System (ECS) developed by the Minnesota Department of Natural Resources (MnDNR)^[4]. The Hardwood Hills Subsection is characterized by steep slopes, high hills, and lakes formed in glacial end moraines and outwash plains. The Continental Divide separates the subsection, and the subsection has numerous lakes, with over 400 lakes larger than 160 acres. Pre-settlement vegetation included tallgrass prairie, aspen-oak land, and oak openings. Agriculture is the predominant land use in the subsection; however wetlands provide habitat and recreational opportunities. Tourism associated with lake and outdoor activities are also important in the subsection.

6.2 Human Settlement

6.2.1 Public Health and Safety

Minnkota will implement proper safeguards during construction and operation to avoid potential impacts to public health and safety. Concerns related to health and safety include hazards associated with coming into contact with energized equipment, induction, and potential impacts to implantable medical devices. In general, impacts to public health and safety from the project are not anticipated.

6.2.1.1 Mitigation Measures

The proposed Project will be designed in compliance with local, state, NESC, and Minnkota standards for clearance to ground, crossing utilities and buildings, strength of materials, and ROW widths. Minnkota will ensure that construction and contract crews comply with local, state, NESC, and Company standards for installation of facilities and standard construction practices. Minnkota and industry safety procedures will also be followed after the proposed Project is installed.

The proposed HVTL will be connected to an existing 115 kV transmission line which is equipped with protective measures to safeguard the public if an accident occurs, such as a structure or conductor falling to the ground. The protective equipment will de-energize the HVTL should such an event occur. The proposed Substation will be fenced. With implementation of safeguards and protective measures, the proposed Project is not anticipated to result in adverse or significant impacts on public health and safety.

6.2.2 Residential and Non-Residential Land Use

The proposed Route is located primarily adjacent to agricultural and pasture land and, to a lesser extent, passes through or adjacent to wooded areas and wetlands. At its starting point in Leon Township, the proposed Route is located adjacent to industrial land uses, with North Dakota Pipeline Company, LLC’s Clearbrook Terminal located immediately north of County Road 74 and Minnesota Pipeline Company’s Clearbrook Station located immediately south of County Road 74. As the line extends west, following County Road 74 and then north along 149th Avenue, existing land use adjacent to the proposed Route is predominantly agricultural, interspersed with forest and wetland areas. Where 149th Avenue terminates, the proposed HVTL would extend northwest, cutting through a mix of agricultural land and forest/wetland areas. The proposed Substation will be constructed on agricultural land and is located adjacent to open field areas. It is anticipated that a 150-foot by 100-foot area will be required to accommodate the proposed Substation.

There are a number of residences located along the proposed Route primarily located adjacent to agricultural land along the east-west portion of the proposed Route that parallels County Road 74. Table 8 summarizes the number of residences and other structures located within the proposed Route ROW and within the route width; locations of residential structures are illustrated in Appendix B.

Table 8 Residential and Non-residential Buildings within Various Distances of Proposed Route

| Structure Type | Number of Structures within Various Distances | |
|-----------------|---|--------------------|
| | Within ROW | Within Route Width |
| Non-Residential | 1 | 7 |
| Residential | 0 | 0 |
| Silos | 0 | 4 |
| Tanks | 0 | 1 |

6.2.3 Displacement

The proposed Project will not require displacement of occupied residences or commercial businesses. Minnkota will seek to construct the HVTL consistent with any applicable zoning ordinances. However, no zoning, building, or land use approvals will be required from surrounding municipalities if a Route Permit is issued for the proposed Project because once the Commission issues a Route Permit, zoning, building, and land use regulations and rules are preempted per Minn. Stat. § 216E.10, subd. 1. No adverse or significant impacts on residential or commercial structures as a result of the proposed Project are anticipated.

6.2.3.1 Mitigation Measures

As discussed in Section 4.2.2 as part of the planning process, the Applicant assessed the general area surrounding the proposed Project to identify significant routing issues that might arise and to evaluate environmental resources in the vicinity of the proposed Project. A team of siting, ROW, planning, environmental, ecological, and engineering personnel worked together to develop a proposed Route that minimizes overall impacts of the proposed Project. Based on this work the proposed Project has been designed to avoid displacement of homes. Because no displacement will occur, no additional mitigation measures are proposed.

6.2.4 Noise

Transmission conductors produce noise under certain conditions. The level of noise depends on conductor conditions, voltage level, and weather conditions. Generally, activity-related noise levels during the operation and maintenance of transmission lines are minimal.

Noise emissions from a transmission line occur during certain weather conditions. In foggy, damp, or rainy weather, power lines can create a crackling sound when a small amount of electricity ionizes the moist air near the wires. During heavy rain, the background noise level of the rain is usually greater than the noise from the transmission line. As a result, people do not normally hear noise from a transmission line during heavy rain. During light rain, dense fog, snow, and other times when there is moisture in the air, transmission lines can produce noise. Noise levels produced by a 115 kV HVTL are generally less than outdoor background levels and are therefore not usually audible. At substations, the source of noise is primarily the transformers, which can create a humming noise.

Since human hearing is not equally sensitive to all frequencies of sound, the most noticeable frequencies of sound are given more “weight” in most measurement schemes. The A-weighted scale corresponds to the sensitivity range for human hearing. Noise levels capable of being heard by humans are measured in decibels (dBA). A noise level change of 3 dBA is barely perceptible to human hearing. A 5 dBA change in noise level, however, is clearly noticeable. A 10 dBA change in noise level is perceived as a doubling of noise loudness, while a 20 dBA change is considered a dramatic change in loudness. Table 9 shows noise levels associated with common, everyday sources.

Table 9 Common Noise Sources and Levels

| Noise Source* | Sound Pressure Level (dBA) |
|--|----------------------------|
| Jet Engine (at 25 meters) | 140 |
| Jet Aircraft (at 100 meters) | 130 |
| Rock Concert | 120 |
| Pneumatic Chipper | 110 |
| Jackhammer (at 1 meter) | 100 |
| Chainsaw, Lawn Mower (at 1 meter) | 90 |
| Heavy Truck Traffic | 80 |
| Business Office, Vacuum Cleaner | 70 |
| Conversational Speech, Typical TV Volume | 60 |
| Library | 50 |
| Bedroom | 40 |
| Secluded Woods | 30 |
| Whisper | 10 |

Source: Minnesota Pollution Control Agency^[5].

In Minnesota, statistical sound levels (“L” or Level Descriptors) are used to evaluate noise levels and identify noise impacts. The standards are expressed as a range of permissible dBA within a one hour period; L₅₀ is the dBA that may be exceeded 50 percent of the time within an hour, while L₁₀ may be exceeded 10 percent of the time within an hour.

Land areas, such as picnic areas, churches, or commercial spaces, are assigned to an activity category based on the type of activities or use occurring in the area. Activity categories are then categorized based on their sensitivity to traffic noise. The Noise Area Classification (NAC) is listed in the Minnesota Pollution Control Agency (MPCA) noise regulations to distinguish the categories. Residential areas, churches, and similar type land use activities are included in NAC 1; commercial-type land use activities are included in NAC 2; and industrial-type land use activities are included in NAC 3.

Table 10 identifies the established daytime and nighttime noise standards by NAC.

Table 10 Noise Standards by Noise Area Classification (dBA)

| NAC | Daytime | | Nighttime | |
|-----|-----------------|-----------------|-----------------|-----------------|
| | L ₅₀ | L ₁₀ | L ₅₀ | L ₁₀ |
| 1 | 60 | 65 | 50 | 55 |
| 2 | 65 | 70 | 65 | 70 |
| 3 | 75 | 80 | 75 | 80 |

Table 11 presents the L₅₀ noise levels predicted for single pole 115 kV structures using the Corona and Field Effects (CFE) spreadsheets developed by the Bonneville Power Administration. The worst case indicated that the audible L₅₀ noise levels measured at the edge of the ROW (50 feet from centerline) are well below the MPCA limits for the relevant noise area classifications (NAC 2 and NAC 3) in the area crossed by the line.

Table 11 Calculated Audible Noise (dBA) for Proposed Transmission Line Designs

| Structure Type | Weather Condition | Noise L ₅₀ (Edge of ROW) (Decibels a weighted) |
|--------------------|-------------------|---|
| 115 kV Single Pole | Rainy | 14.2-14.6 |
| | Fair | 1.8-2.2 |

The noise generated from the proposed HVTL is not expected to exceed background noise levels and will, therefore, not be audible at any receptor location. The proposed HVTL will be designed and constructed to comply with state noise standards established by the MPCA. Any audible noise will be below the MPCA noise standards established for NAC 1. Additionally, it is not anticipated that the proposed Project will increase noise from HVTL conductors or any associated facilities above the levels already experienced in the area.

Transformer “hum” is the dominant noise source at substations. Transformer hum is caused by magnetic forces within the core of the transformer. These magnetic forces cause the core laminations to expand and contract, creating vibration and sound at a frequency of 120 Hz (twice the a.c. mains frequency), and at multiples of 60Hz (harmonics). Typically, the noise level does not vary with transformer load, as the core is magnetically saturated and cannot produce any more noise.

Given the distance of over 4,000 feet from the proposed Substation to the nearest home, it would be very unlikely that substation noise would be audible to residents. The proposed Substation will be designed and constructed to comply with state noise standards established by the MPCA.

With implementation of state design and construction standards, the proposed Project is not anticipated to result in adverse or significant impacts on the public as a result of noise.

6.2.4.1 Mitigation Measures

As discussed in Section 4.2.2 as part of the planning process, the Applicant assessed the general area surrounding the proposed Project to identify significant routing issues that might arise and to evaluate environmental resources in the vicinity of the proposed Project. A team of siting, ROW, planning, environmental, ecological, and engineering personnel worked together to develop a proposed Route that minimizes overall impacts of the proposed Project. Based on this work the proposed Project has been designed to avoid proximity to sensitive noise receptors (homes) and no additional mitigation measures are proposed.

6.2.5 Television and Radio Interference

Corona from transmission line conductors can generate electromagnetic “noise” at the same frequencies that radio and television signals are transmitted. This noise can cause interference with the reception of these signals depending on the frequency and strength of the radio and television signal. Tightening loose hardware on the transmission line usually resolves the problem.

If radio interference from transmission line corona does occur, satisfactory reception from AM radio stations previously providing good reception can be restored by appropriate modification of (or addition to) the receiving antenna system. AM radio frequency interference typically occurs immediately under a transmission line and dissipates rapidly within the ROW to either side.

FM radio receivers usually do not pick up interference from transmission lines because:

- corona-generated radio frequency noise currents decrease in magnitude with increasing frequency and are quite small in the FM broadcast band (88-108 Megahertz); and
- the excellent interference rejection properties inherent in FM radio systems make them virtually immune to amplitude type disturbances

A two-way mobile radio located immediately adjacent to and/or behind a large metallic structure (such as a steel tower) may experience interference because of signal-blocking effects. Movement of either mobile unit so that the metallic structure is not immediately between the two units should restore communications. This will generally require a movement of less than 50 feet by the mobile unit adjacent to a metallic tower.

Television interference is rare but may occur when a large transmission structure is aligned between the receiver and a weak distant signal, creating a shadow effect. Loose and/or damaged hardware may also cause television interference. If television or radio interference is caused by or from the operation of the proposed facilities in those areas where good reception is presently obtained, the Applicant will inspect and repair any loose or damaged hardware in the HVTL, or take other necessary action to restore reception to the present level, including the appropriate modification of receiving antenna systems if deemed necessary.

6.2.5.1 Mitigation Measures

The Applicant does not anticipate that the proposed Project would create interference with radio or television signals, however if radio or television interference occurs due to the proposed Project, the Applicant will work with the affected landowner to restore reception to pre-Project quality.

6.2.6 Aesthetics

Aesthetics refer to the natural and human modified landscape features or visual resources that contribute to the public’s experience and appreciation of the environment. Wetlands, surface waters,

landforms, forests, and vegetation patterns are among the natural landscape features that define an area's visual character. Buildings, roads, bridges, and other structures reflect human modifications to the landscape. The scenic value or visual importance of an area is a subjective matter and depends upon the perception and philosophical and/or psychological response of the viewer. Generally, landscapes that exhibit a high degree of variety and harmony among the basic elements of form, line, color, and texture have the greatest potential for high visual and aesthetic quality. The level of impact to visual resources is also subjective and generally depends on the sensitivity and exposure of a particular viewer and can, therefore, vary greatly from one individual to the next.

The proposed Project will be constructed primarily adjacent to existing road ROW line and, on the eastern end of the proposed Route, adjacent to industrial infrastructure. Therefore, the proposed Project is not expected to change the nature of the existing viewshed in the Project area. As discussed in Section 5.1.1, the proposed Route will primarily use wood or steel monopole structures with an average pole height of 65 feet and approximately 300-foot to 325-foot span length.

These proposed HVTL structures will be visible to drivers traveling along County Road 74 and 149th Avenue and will be visible to residents located near the proposed Route. However, given the existing infrastructure in the immediate vicinity, the proposed Project is not expected to appreciably alter the visual experience of travelers and residents in the area.

6.2.6.1 Mitigation Measures

The proposed Route maximizes ROW sharing with existing linear corridors (distribution lines and roadways) to minimize the proliferation of visual impacts to open spaces. Where the proposed Project parallels the south side of County Road 74, existing low-voltage distribution lines will be removed and buried by Clearwater-Polk Electric Cooperative. During the construction, uniform structure types will be used to the extent practicable.

6.2.7 Socioeconomic

Population and economic characteristics based on the 2010 U.S. Census are provided in Table 12. As reported in the 2010 U.S. Census, the population density of Clearwater County is 8.7 people per square mile. Minorities and persons living in poverty make up 11 percent and 15.1 percent of the population, respectively. For comparison, minorities comprise 15.9 percent of the statewide population and 11 percent of Minnesota residents live in poverty^[6].

At 5.3 percent, the minority population in Clearbrook is slightly lower than in Clearwater County as a whole. Per capita income in Clearbrook is also slightly lower than the county as a whole^[7]. No disproportionate impacts are anticipated to minority or low-income populations.

Table 12 Population and Economic Characteristics

| Location | Population | Minority Population (percent) | Caucasian Population (percent) | Per Capita Income | Percentage of Population Below Poverty Level |
|-------------------|------------|-------------------------------|--------------------------------|-------------------|--|
| Clearbrook | 518 | 5.3 | 94.6 | 13,052 | 10.5 |
| Clearwater County | 8,523 | 11 | 89 | 21,876 | 15.1 |

Approximately 25 workers will be required for HVTL construction and 12 workers will be needed, on average, for the proposed Substation construction.

There will be minor short-term impacts to community services as a result of construction activity and an influx of contractor employees during construction of the proposed Project. Utility personnel or contractors will be used for all construction activities. The communities near the Project area may experience a minor short-term positive economic impact through the use of the hotels, restaurants, and other services by the various workers.

It is not expected that additional permanent jobs will be created by the proposed Project. The construction activities will provide a seasonal influx of additional dollars into the communities during the construction phase, and materials such as concrete may be purchased from local vendors where feasible. Long-term beneficial impacts from the proposed HVTL and proposed Substation construction include increased local tax base resulting from the incremental increase in revenues from utility property taxes.

6.2.7.1 Mitigation Measures

Socioeconomic impacts resulting from the proposed Project will be primarily positive with an influx of wages and expenditures made at local businesses during Project construction, and increased tax revenue once the proposed Project is operational. No mitigation measures are proposed.

6.2.8 Cultural Values

Cultural values include those perceived community beliefs or attitudes that provide a framework for unity in a given community. The communities near the proposed Project value outdoor recreation and the scenic nature of the northwoods region. The communities in the Project area have cultural ties to German, Norwegian, Swedish, English, and Native American heritages^[8]. Cultivated wild rice paddies are located north of Clearbrook. Wild rice has cultural significance for tribal communities^[7]. Clearbrook is home to a large wild rice processing plant^[7]. The proposed Project is not expected to impact the framework or sense of unity of the community and will not alter features in the area that contribute significantly to the cultural nature of the region.

6.2.8.1 Mitigation Measures

No impacts are anticipated and, therefore, no mitigation measures are proposed.

6.2.9 Recreation

The Project area is located in a region that is known for its outdoor recreation opportunities. The region includes vast areas of forest, lakes, rivers, and streams, making it a destination for outdoor recreation. The area offers opportunities for walleye and northern pike fishing, kayaking, boating, cycling, hiking, hunting, cross country skiing, and snowmobiling.

The proposed Project is not located in the immediate vicinity of any recognized recreational area. Direct impacts to existing recreational opportunities are not expected to occur as the proposed Route is located in an area that is adjacent to a major roadway as well as existing industrial and electrical infrastructure.

6.2.9.1 Mitigation Measures

No impacts are anticipated and, therefore, no mitigation measures are proposed.

6.2.10 Public Services

Public services and facilities in the Project area generally include emergency services provided by government entities, including hospitals, fire departments, and police departments, water supply or wastewater disposal systems, and gas and electricity services, and existing and future transportation corridors and projects.

6.2.10.1 Emergency Services

Any required temporary lane closures on County Road 74 will be coordinated with the local jurisdictions, and will provide for safe access of police, fire, and other rescue vehicles.

6.2.11 Utilities

Construction and operation of the proposed Project is not anticipated to impact any public service utilities. The Project is needed to address Minnkota's customer industrial load in the Clearbrook area. Where the proposed Project parallels the south side of County Road 74, existing low-voltage distribution lines will be removed and buried by Clearwater-Polk Electric Cooperative.

6.2.12 Transportation and Traffic

Roads are the main transportation infrastructure in the Project area. The proposed Route runs parallel to and crosses County Road 74 before turning north to parallel 149th Avenue. Roadways can potentially be impacted temporarily during construction activities and during maintenance of the HVTL. Impacts could result from construction vehicles and safety perimeters temporarily blocking public access to streets. Access during construction and maintenance is expected to be primarily from existing roads. Due to the temporary nature of the proposed construction activities, traffic disruptions are expected to

be minor and temporary. Structure placement along roadways can also impact future road expansions, as structures placed within the ROW must be moved to allow a safe distance between structures and the edge of the roadway.

The closest airport to the Project area is a private strip in Gonvick, Minnesota, which is located approximately 5 miles northwest of the City of Clearbrook. Tall HVTLs can conflict with the safe operation of public and private airports and air strips. The Federal Aviation Administration (FAA) and MnDOT have each established development guidelines on the proximity of tall structures to public use airports. The FAA has also developed guidelines for the proximity of structures to Very-High-Frequency Omni-Directional Range (VOR) navigation systems. Due to the distance between the private air strip and the proposed Project, construction and operation of the proposed HVTL and proposed Substation are not anticipated to impact safe operation and use of the airport.

6.2.12.1 Mitigation Measures

No impacts to emergency services are anticipated, Minnkota will minimize potential impacts through coordination of the construction with local and state road authorities and use signage during construction to alert drivers. No significant conflicts are anticipated.

Operation of the HVTL is not expected to impact traffic along these roadways and pole placement and construction procedures will be developed in consultation with state and county roadway authorities to meet requirements for clear zones and roadside obstructions. Planning for the proposed Project will also be coordinated with MnDOT and Clearwater County transportation policies to minimize impacts from construction of the proposed Project.

6.3 Land Based Economics

6.3.1 Agriculture

Federal regulations define prime farmland as “land that has the best combination of physical and chemical characteristics for producing food, feed, forage, fiber, and oilseed crops and is available for these uses.” (7 C.F.R. 657.5(a)(1)). Table 13 identifies the types and acreages of farmland within the proposed Route and proposed Substation Location.

Areas identified as prime farmland and as prime farmland if drained (soils that have the potential to be prime farmland but will require hydrologic alteration) occur within the proposed Route; representing approximately 70 percent of the area within the 100-foot ROW and 55 percent of area within the route width. However, the amount of agricultural land removed from production will be minimal.

The entire 150-foot by 100-foot area that has been identified to accommodate the proposed Substation location is designated as prime farmland.

Generally, HVTL construction activities can result in impacts to agricultural lands, including soil erosion, interference with and damage to agricultural surface and subsurface drainage and irrigation systems,

mixing or loss of topsoil and subsoil, and soil compaction. Given the location of the proposed project primarily along existing roadway corridor, however, these impacts are expected to be minimal.

Table 13 Prime Farmland within ROW and Routes and Proposed Substation Location

| Project Area | Prime Farmland (Acres) | | Prime Farmland if Drained (Acres) | |
|------------------------------|------------------------|-------|-----------------------------------|-------|
| | ROW | Route | ROW | Route |
| Proposed Route | 35.6 | 141.6 | 9.4 | 37.7 |
| Proposed Substation Location | NA | 0.35 | 0 | 0 |

6.3.1.1 Mitigation Measures

Landowners will be compensated for the use of their land through easement payments. Additionally, the Applicant intends to minimize loss of farmland and rural properties and to ensure reasonable access to the land near the structures by overlapping with existing ROW along the existing Clearwater-Polk Electric Cooperative distribution line corridor south of County Road 74 and using monopole structures.

Permanent impacts to cropland will occur where HVTL structures are placed on cropland. In areas where cropland is crossed, temporary impacts such as soil compaction and crop damages within the ROW may occur. When possible the Applicant will construct the poles before crops are planted. However, if construction after crop planting is necessary, disturbance to farm soil from access to each structure location will be minimized by using the shortest access route. This may require construction of temporary driveways between the roadway and the structure, but will limit traffic on fields between structures. Construction mats may also be used to minimize impacts on the access paths and in construction areas. The Applicant’s construction team will work with the property owner, ROW agent, and engineers to minimize the impact on property through use of the landowner’s knowledge of the property. In addition to payments for easements acquired, the Applicant will compensate landowners for any crop damage and soil compaction that occurs as a result of the proposed Project.

6.3.2 Forestry

There are no known tree farms or federal or state forests located within the proposed Project or proposed Substation Location.

6.3.2.1 Mitigation Measures

No impacts to forestry resources are anticipated and, therefore, no mitigation measures are proposed.

6.3.3 Tourism

No tourist areas are present within the proposed Route or proposed Substation Location area. However, nearby lakes, rivers, parks, and wildlife management areas (WMAs), such as the Little Pine State WMA

(located approximately 1.3 miles from the proposed Project), provide a variety of outdoor recreational activities for tourists visiting the area (Figure C-1).

6.3.3.1 Mitigation Measures

No impacts to tourism resources are anticipated and, therefore, no mitigation measures are proposed.

6.3.4 Mining

There are no gravel pits, rock quarries, commercial aggregate sources, or any other mining resources located within the Project area or proposed Substation Location.

6.3.4.1 Mitigation Measures

No impacts to mining resources are anticipated and, therefore, no mitigation measures are proposed.

6.4 Archaeological and Historic Resources

Archaeological and historic resources are those places that represent the visible or otherwise tangible record of human occupation. These resources vary in size, shape, condition, and importance, among other considerations; some are evident on the landscape, while others are buried or only visible to knowledgeable people.

In July 2014, Barr Engineering Company (Barr), on behalf of the Applicant, requested and received a database summary from the State Historic Preservation Office (SHPO) identifying documented archaeological and historic resources within one mile of the proposed Project (Figure C-4). Additionally, *10,000 Lakes Archaeology, Inc.* conducted Phase Ia background research, reviewing the results of the July 2014 SHPO database request as well as examining Minnesota Archaeological Site Files at the Office of the State Archaeologist (OSA) and SHPO and Minnesota Architectural History Site Files at SHPO (Appendix E). This research revealed that two archaeological sites have been recorded approximately one and one half miles from the proposed Project, and four archaeological sites have been recorded within less than half a mile of the proposed Project. In addition, nine areas with moderate to high potential for unrecorded archaeological sites were also identified. These locations were defined by considering many factors such as proximity to water, proximity to recorded archaeological sites, and topography. In addition to the recorded archaeological sites, 22 historic resources have been recorded within one half mile of the proposed Project, and two have been recorded approximately one and one half miles from the proposed Project (Table 14). All historic sites are located within Clearbrook except two (CE-PLK-00k and CE-PLK-002) which are over one mile northwest of the Project area.

Table 14 Identified Archaeological and Historic Resources within 1 ½ Mile of the Proposed Project

| Site Type | State Site Number | Location | Site Description | Distance from Project Area |
|----------------|--------------------------------------|----------------------|--|----------------------------|
| Archaeological | 21CE0031 | T149N, R37W, Sec. 34 | Ruins of an historic farmstead with silo and windmill | 1½ miles |
| Archaeological | 21CEq | T149N, R38W, Sec. 27 | Precontact ceramics were found at this location in 1938. Site has not been verified by archaeologists. | 1½ miles |
| Archaeological | 21CE0078 | T49N, R37W, Sec. 32 | Single lithic | ½ mile |
| Archaeological | 21CE0079 | T149N, R38W, Sec. 23 | Historic farmstead | <1/4 mile |
| Archaeological | 21CE0080 | T149N, R37W, Sec. 31 | Single lithic tool | <1/4 mile |
| Archaeological | 21CE0081 | T149N, R38W, Sec. 36 | Historic site | ½ mile |
| Historic | CE-CBC-001 | T149N, R37W, Sec. 29 | House | <1 mile |
| Historic | CE-CBC-002 | T149N, R37W, Sec. 29 | House | <1 mile |
| Historic | CE-CBC-003 | T149N, R37W, Sec. 29 | Shelquist House | <1 mile |
| Historic | CE-CBC-004 | T149N, R37W, Sec. 29 | Lewis House | <1 mile |
| Historic | CE-CBC-005 | T149N, R37W, Sec. 29 | Hotel | <1 mile |
| Historic | CE-CBC-006 | T149N, R37W, Sec. 29 | First State Bank | <1 mile |
| Historic | CE-CBC-007 | T149N, R37W, Sec. 29 | School | <1 mile |
| Historic | CE-CBC-008 | T149N, R37W, Sec. 29 | Warehouse | <1 mile |
| Historic | CE-CBC-009 | T149N, R37W, Sec. 29 | Clearbrook Co-op Elevator | <1 mile |
| Historic | CE-CBC-010 | T149N, R37W, Sec. 29 | Clearbrook Depot | <1 mile |
| Historic | CE-CBC-011 | T149N, R37W, Sec. 29 | Clearbrook Co-op Creamery | <1 mile |
| Historic | CE-CBC-012 | T149N, R37W, Sec. 29 | House | <1 mile |
| Historic | CE-CBC-013 | T149N, R37W, Sec. 29 | House | <1 mile |
| Historic | CE-CBC-014 | T149N, R37W, Sec. 29 | House | <1 mile |
| Historic | CE-CBC-015 | T149N, R37W, Sec. 29 | House | <1 mile |
| Historic | CE-CBC-016 | T149N, R37W, Sec. 29 | House | <1 mile |
| Historic | CE-CBC-017 | T149N, R37W, Sec. 29 | House | <1 mile |
| Historic | CE-CBC-018 | T149N, R37W, Sec. 29 | House | <1 mile |
| Historic | CE-LEN-003 | T149N, R37W, Sec. 29 | Minnesota Pipe Line Company Terminal | <1 mile |
| Historic | CE.LEN-005 | T149N, R37W, Sec. 32 | Silver Creek Creamery | <1 mile |
| Historic | CE-LEN-006 | T149N, R37W, Sec. 33 | House and outbuildings | <1 mile |
| Historic | CE-PLK-002 | T149N, R38W, Sec. 15 | Farmstead | <1½ mile |
| Historic | CE-PLK-00k | T149N, R38W, Sec. 15 | Farmstead | <1½ mile |
| Historic | GD-LEO-022 (Should be CE-LEN-022) | T149N, R37W, Sec. 29 | Clearbrook Terminal | <1 mile |

10,000 Lakes Archaeology, Inc. was retained to complete a Phase I cultural resources survey within the nine areas with moderate to high potential for unrecorded archaeological sites based on the outcomes of the Phase Ia background research. Landowner permission was not provided for shovel testing in one area of with moderate to high potential for unrecorded archaeological sites, however, negotiations with

the landowner are ongoing and a Phase I cultural resource survey will be conducted for this area upon obtaining landowner permission or following ROW acquisition.

Phase I archaeological survey methods typically involve archaeologists walking areas where over 25% of the ground surface is visible (e.g. agricultural fields) in transects at five to 15-meter (m) intervals as appropriate. In areas where less than 25% of the ground surface is visible, or where buried archaeological sites have a high probability of existing, archaeologists excavate shovel tests. These excavations measure 30 to 40 centimeters in diameter and are placed at 15-m intervals within areas of moderate and high potential, as appropriate. Soil is screened through ¼-inch mesh hardware cloth to determine if cultural materials are present. The methods used for the archaeological survey are further discussed in the Phase I Archaeological Survey are provided in Appendix E.

The archaeological survey took place in October of 2014 and located no previously unrecorded archaeological sites. One recorded archaeological site exists immediately west of the proposed Substation Location at the far northwestern end of the HVTL and two recorded cemeteries are present along the proposed corridor, but both are located on the side of County Road 74 opposite of the proposed alignment.

Per the recommendations in *10,000 Lakes Archaeology, Inc.'s* Phase 1 cultural resources survey report, the proposed Project will avoid crossing through the two cemeteries. SHPO has determined that the site on the northwest end of the proposed Project is not eligible for listing on the National Register of Historic Places (NRHP). Since this site is not eligible and the cemeteries will be avoided, no impacts to archaeological or historic resources are anticipated. A summary of the Phase Ia review and Phase I Archaeological Survey are provided in Appendix E.

Initial comments on the proposed project provided by SHPO prior to the completion of the cultural resources review are provided in Appendix G as well as SHPO correspondence regarding NRHP listing eligibility of the site on the northwest end of the proposed Project. This correspondence addresses the obligation to consult with SHPO under Section 106 of the National Historic Preservation Act (NHPA). Consultation under NHPA also included contacting tribal entities in the project area by letter. Further information is provided in Section 7.2.

6.4.1.1 Mitigation Measures

During construction, avoidance of known resources would be the primary mitigation. Avoidance of resources may include minor adjustments to the project design and the designation of sensitive areas that must not be disturbed by the project. If unanticipated archaeological or historic resources are discovered during construction, it would be necessary to cease construction activities at that location and contact the SHPO for their assistance in the development of appropriate measures to protect the resource. In addition, if human remains or suspected burial sites are discovered during construction, the State Archaeologist would be contacted and construction would cease at the location until adequate mitigation measures are developed.

6.5 Natural Environment

6.5.1 Air Quality

Potential air quality effects related to transmission facilities include fugitive dust emissions during construction, exhaust emissions from construction equipment, and ozone generation during HVTL operation. All of these potential effects are considered to be relatively minor, and all but the ozone effects are short-term.

State and federal governments currently regulate permissible concentrations of ozone and nitrogen oxides. Ozone forms in the atmosphere when nitrogen oxides and volatile organic compounds react in the presence of heat and sunlight. Air pollution from cars, trucks, power plants, and solvents contribute to the concentration of ground-level ozone through these reactions. Currently, both state and federal governments regulate permissible concentrations of ozone and nitrogen oxides. The national standard is 0.075 parts per million (ppm) during an 8-hour averaging period. The state standard is 0.08 ppm based upon the fourth-highest 8-hour daily maximum average in 1 year. There are currently no non-attainment areas listed for Clearwater County^[9].

The only potential air emissions from a transmission line result from corona, and such emissions are limited. Corona consists of the breakdown or ionization of air within a few centimeters immediately surrounding conductors and can produce ozone and oxides of nitrogen in the air surrounding the conductor. This process is limited because the conductor electrical gradient of a 115 kV HVTL is usually less than that necessary for the air to break down. Typically, some imperfection such as a scratch on the conductor or a water droplet is necessary to cause corona.

Ozone is not only produced by corona, but also forms naturally in the lower atmosphere from lightning discharges and from reactions between solar ultraviolet radiation and air pollutants such as hydrocarbons from auto emissions. The natural production rate of ozone is directly proportional to temperature and sunlight and inversely proportional to humidity. Thus, humidity (or moisture), the same factor that increases corona discharges from transmission lines, inhibits the production of ozone. Ozone is a reactive form of oxygen and combines readily with other elements and compounds in the atmosphere. Because of its reactivity, it is relatively short-lived.

During construction of the proposed HVTLs, minor emissions from vehicles and other construction equipment and fugitive dust from ROW clearing will occur, but will be limited. Air-quality impacts during the construction phase will also be temporary. The magnitude of construction emissions is heavily influenced by weather conditions and the specific construction activity. Exhaust emissions, primarily from diesel equipment, will vary according to the phase of construction, but will be minimal and temporary. Adverse impacts on the surrounding environment will be minimal because of the short and intermittent nature of the emission and dust-producing construction phases.

The proposed Project is not anticipated to result in adverse or significant effects on air quality.

6.5.1.1 Mitigation Measures

The Applicant will employ BMPs to minimize the amount of fugitive dust created by the construction process. Tracking control at access roads and wetting surfaces are examples of BMPs that will be used to minimize fugitive dust. Based upon this, the Applicant anticipates nominal impacts to air quality. No other mitigation measures are proposed.

6.5.2 Water Resources

6.5.2.1 Water Quality

The proposed Project may have minor, short term effects on water quality. Impacts on water quality are possible during the construction phase of the proposed Project, when sediment could possibly reach surface waters as excavation, grading, and construction traffic disturb the ground.

6.5.2.2 Mitigation Measures

The MPCA regulates construction activities that may impact storm water under the Clean Water Act. In the event that a National Pollutant Discharge Elimination System (NPDES) construction storm water permit and Stormwater Pollution Prevention Plan (SWPPP) are required for the proposed Project, the Applicant will obtain the permit and prepare a SWPPP. An NPDES permit is required for owners or operators for any construction activity disturbing: 1) one acre or more of soil; 2) less than one acre of soil if that activity is part of a "larger common plan of development or sale" that is greater than one acre; or 3) less than one acre of soil, but the MPCA determines that the activity poses a risk to water resources. The SWPPP will outline strategies and steps that will be taken to prevent nonpoint source pollution discharging from construction areas.

Additionally, the proposed Substation will have a crushed aggregate surface which will limit impacts to ground water and BMPs, such as silt fence, will be implemented in order to prevent or minimize water quality impacts during Project construction. Using the previously outlined measures, no significant impacts to water quality are anticipated.

6.5.2.3 MnDNR Public Waters Inventory

The MnDNR Public Waters Inventory (PWI) identifies basins (lakes and wetlands) and watercourses over which the MnDNR has regulatory jurisdiction. The statutory definition of public water is found in Minn. Stat. § 103G.005, subd. 15 and 15a. Two PWI watercourses are crossed by the proposed Route (Figure C-2). Minn. Stat. § 84.415 requires project developers intending to cross over, under, or across any state land or public water with any utility (pipelines, power lines, etc.) need to first secure a MnDNR license to cross. No PWI basins are present within the proposed Route or proposed Substation Location, Erie Lake and Steenerson Lake are located within 500' of the Proposed route (Figure C-2).

Minnkota will seek to construct the HVTL consistent with Clearwater County's shoreland zoning ordinances which addresses intensive vegetation removal within a shore impact zone of 75 feet for lakes and 50 feet for streams and rivers. A minimum of a 50-foot buffer on each side of the PWI watercourse

crossings and a 75-foot buffer of the lakes will be maintained and no poles will be located within the buffers. Removal of vegetation within the buffers will be minimized to the greatest extent possible; only woody vegetation will be removed at the ground surface.

6.5.2.4 Mitigation Measures

Pole placement will be selected to avoid PWI watercourses and basins. Additionally, poles will not be placed within a 50-foot buffer of the watercourses and a 75-foot buffer of the lakes. To avoid sedimentation of the waterbodies, only woody vegetation within the buffers will be removed at the ground surface, allowing for the existing root systems to stay in place and stabilize soils adjacent to the waterbodies. The Applicant will limit tree clearing and removal to the HVTL ROW, areas that limit construction access to the Project area, and areas that impact the safe operation of the facilities.

6.5.2.5 Wetlands

Wetland locations within the Project area were identified using the United States Fish and Wildlife Service (USFWS) National Wetland Inventory (NWI) maps. Wetlands are summarized in Table 15 and shown on Figure C-2.

Approximately 21.77 acres of wetland have been mapped within the route width. Of the total wetlands present approximately 51 percent are emergent wetlands, 3 percent are forested, and 46 percent are scrub shrub. The proposed Route would require eight wetland crossings ranging in size from approximately 85 feet to approximately 350 feet. The maximum span length for the proposed single pole HVTL is 325 feet. Therefore the wetland crossing measuring greater than 325 feet will be spanned using three pole structures.

No wetlands were identified at the proposed Substation location.

Table 15 Acres of Wetland within Routes/ROW and Proposed Substation Location

| Cowardin Wetland Type | Wetland (acres) | | |
|-----------------------|-----------------|--------------|---------------------|
| | Proposed Route | | Substation Location |
| | ROW | Route | |
| Emergent | 0.98 | 11.1 | 0 |
| Forested | 0.31 | 0.57 | 0 |
| Scrub Shrub | 1.7 | 10.1 | 0 |
| Unconsolidated Bottom | 0.0 | 0.0 | 0 |
| Total acres | 2.99 | 21.77 | 0 |

6.5.2.6 Mitigation Measures

The HVTL will be designed to span wetlands to the extent possible. The Applicant has designed the proposed Project to avoid and minimize wetland impacts, and will apply erosion control measures identified in the Minnesota Pollution Control Agency (MPCA) Storm Water BMPs Manual, such as using silt fencing to minimize impacts to water quality.

As previously stated in 6.5.2.1, the MPCA regulates construction activities that may impact storm water under the Clean Water Act. In the event that a National Pollutant Discharge Elimination System (NPDES) construction storm water permit and Stormwater Pollution Prevention Plan (SWPPP) is required for the proposed Project, the Applicant will obtain the permit and prepare a SWPPP. An NPDES permit is required for owners or operators for any construction activity disturbing: 1) one acre or more of soil; 2) less than one acre of soil if that activity is part of a "larger common plan of development or sale" that is greater than one acre; or 3) less than one acre of soil, but the MPCA determines that the activity poses a risk to water resources. The SWPPP will outline strategies and steps that will be taken to prevent nonpoint source pollution discharging from construction areas.

6.5.2.7 Floodplain

This area has not been mapped for floodplains by the Flood Emergency Management Agency (FEMA)^[10].

6.5.2.8 Mitigation Measures

No impacts to floodplain resources are anticipated; therefore, no mitigation measures are proposed.

6.5.3 Flora

The MnDNR Gap Analysis Program (GAP) Land Cover data set^[11] was used to identify land cover types in the Project area. GAP land cover types within the proposed Route and proposed Substation Location are shown on Figure C-3.

The GAP land cover data identifies just over 40 percent of the land within the proposed route width as developed/urban (roadway and roadway ROW in the Project area are classified by GAP as developed/urban), and just over 40 percent of the land within the proposed Route as agricultural. Additional land cover types include forest and wetland (Figure C-3).

Current GAP-reported land cover in the proposed Substation location is forest (Figure C-3).

6.5.2.9 Mitigation Measures

Impacts to non-forested areas will be temporary and will primarily occur during construction of the proposed Project. To minimize impacts to trees in the Project area, the Applicants will limit tree clearing and removal to the HVTL ROW, areas that limit construction access to the Project area, and areas that impact the safe operation of the facilities. Trees outside the ROW that may need to be trimmed or removed will primarily include trees that are unstable and could potentially fall into the transmission facilities. The Applicant will work with and compensate landowners for removal of trees not in the ROW.

Construction equipment has the potential to spread noxious weed-propagating material to new locations. The Applicant will comply with Minnesota noxious weed laws as described in Minn. Stat. § 18.75 to 18.91 and avoid the transport of state prohibited noxious weeds as well as secondary noxious weeds on the Clearwater County weed list. All areas disturbed by construction of the HVTL will be reseeded using a native seed mix appropriate to the site.

6.5.4 Fauna

No USFWS Waterfowl Production Areas (WPA) are located within the vicinity of the proposed Project or the proposed Substation area. The Little Pine State WMA is located approximately 1.3 miles away and given the distance from the proposed project is unlikely to be impacted. The croplands, grasslands, shrublands, and wetlands in the immediate project area provide habitat for a variety of fauna that are commonly found in rural areas. These species may include deer, small mammals, waterfowl, raptors, perching birds, and amphibians. Because much of the Project area is located within or adjacent to a road, fauna present in the area are likely adapted to anthropogenic disturbance. Therefore it is not likely that the construction, operation, or maintenance of the proposed Project will have any notable effect on fauna present in the area.

The primary potential impact presented to fauna by transmission lines is the potential injury and death of migratory birds such as raptors, waterfowl, and other large bird species. The electrocution of large birds, such as raptors, is more commonly associated with small distribution lines than large transmission lines. However, birds have the potential to collide with all elevated structures, including transmission lines. Avian collisions with transmission lines can occur in proximity to agricultural fields that serve as feeding areas, wetlands and water features, and along riparian corridors that may be used during migration. The majority of the Project area is located adjacent to road ROWs with existing distribution lines that will be buried by Clearwater-Polk Electric Cooperative in conjunction with the proposed Project (Appendix B). Because of this, new impacts to wildlife species from the proposed Project are not anticipated.

6.5.2.10 Mitigation Measures

Displacement of fauna is anticipated to be minor and temporary in nature, and no long-term population-level impacts are anticipated from the proposed Project. The Applicant will construct the HVTL according to Avian Power Line Interaction Committee (APLIC) recommended safety design standards regarding avian collisions and avian electrocution with HVTLs^[12]. In addition, the Applicant will install bird flight diverters where the line crosses a water body to reduce the likelihood of avian collisions.

6.6 Rare and Unique Natural Resources

The USFWS list of federally threatened, endangered, proposed, and candidate species was reviewed^[13] to obtain information on federally-listed species that could be present in the Project area. According to the USFWS list, Clearwater County, is within the overall range of the Canada lynx (*Lynx Canadensis*;

federally threatened). Due to the industrial nature of the Project area and the lack of desirable Canada lynx habitat (dense forest), the proposed Project will have no effect on the Canada lynx.

USFWS has also listed the gray wolf (*Canis Lupus*) as threatened in Clearwater County. Due to the industrial nature of the Project area and the limited availability of desirable habitat, it is unlikely, but possible that gray wolf may be present in the proposed Project area. Adult and juvenile wolves are unlikely to remain in the proposed Project area during construction activities. However, a wildlife biologist will complete a review of the route to confirm that no suitable denning sites are present in the proposed Project area prior to construction. Because adult and juvenile wolves can leave the project area during construction and a survey will confirm no suitable denning sites in the project area prior to construction, it is anticipated that the proposed Project will have no effect on the gray wolf.

The northern long-eared bat (*Myotis septentrionalis*) is also listed as threatened in Clearwater County. Potential summer roosting habitat for the federally-threatened northern long-eared bat may be present within the Project area. Northern long-eared bat habitat can be classified as trees measuring at least 3 inches in diameter with peeling bark or crevices. It is not known whether trees fitting this description are present where tree clearing may be required.

In order to fulfill federal review requirements under Section 7 of the Endangered Species Act, the USFWS has been contacted to address the potential for impacts to federally listed species (Section 7.2 of this route permit application).

In addition to the review of the USFWS federally threatened, endangered, proposed, and candidate species list, MnDNR Natural Heritage Information System (NHIS) database was queried in July 2014 in order to obtain information on rare and unique natural resources within one mile of the Project area. According to the NHIS database, the double-crested cormorant (*Phalacrocorax auritus*) has been documented within one mile of the proposed Route (Figure B-1); however, this is not a species that is currently listed with the MnDNR.

According to the NHIS database, no other state or federally listed species, rare communities or sites of biodiversity significance have been documented within one mile of the Project area.

The bald eagle is not protected by the state or federal threatened and endangered species programs in Minnesota. However, under the Bald and Golden Eagle Act, bald eagle nest structures may not be removed, regardless of bird activity or time of year. If a nest is identified in a tree which would otherwise require removal for construction activities, this tree must be marked for preservation and appropriate avoidance measures employed, including buffer zones, time of year restrictions, or project realignment if necessary.

6.6.1.1 Mitigation Measures

Because the proposed Project is located within or adjacent to road ROWs, and existing distribution line ROWs, it is not likely that the proposed Project will result in significant impacts to rare species in the

area. As previously mentioned, the Applicant will construct the transmission line according to APLIC recommended safety design standards regarding avian collisions and avian electrocution with HVTLs^[12].

The proposed Project will be designed to minimize impacts to rare and unique resources to the extent practicable. In the event that avoiding impacts to threatened or endangered species is not feasible, the Applicant will work with regulatory agencies to identify appropriate measures to minimize impacts, as well as compensatory mitigation for impacts that cannot be avoided.

7.0 Agency Involvement, Public Participation and Required Permits and Approvals

7.1 Project Notices to Agencies, LGUs, and Interested Parties

On October 20, 2014, Minnkota submitted pre-filing notice letters to the Local Governmental Unit (LGU) within the Project area to provide the LGU notice of the proposed Project, requesting comments and concerns, and allowing the LGU the opportunity to request a meeting to discuss the proposed Project. This LGU letter is included in Appendix F.

Clearwater County Environmental Services responded on October 22, 2014 (Appendix G) indicating the county's intention to regulate vegetation removal within the shoreland management areas of the two watercourse crossings and Erie Lake. No structures will be placed within 50 feet of watercourses or within 75 feet of the nearby PWI basins. Vegetative clearing will be minimized within the buffers to the greatest extent possible and woody vegetation will be cut off at the ground level. The county indicated that if the shoreland regulations were resolved through the MPUC route permit process, no additional follow up was required.

Per Minn. Stat. § 216E.10, subd. 1, local land use regulations are preempted once the Commission issues a Route Permit. Given that pole placement will not occur within the previously defined PWI buffer areas and the proposed mitigation measures to minimize vegetative clearing within the buffers and to remove woody vegetation at the ground level leaving the root systems intact, all county-presented concerns have been addressed.

7.2 United States Rural Utilities Service

As the proposed project will be financed through RUS, an Environmental Report will be prepared to fulfill National Environmental Policy Act (NEPA) requirements. Consultation under the NHPA Section 106 and ESA Section 7 will be required.

Section 106 of the NHPA(16 U.S.C. 470) requires that Federal agencies take into account the potential effects of their proposed actions (undertakings) on historic properties, and to develop measures to avoid, minimize, or mitigate any adverse effects. The NHPA also requires federal agencies to consult with Indian Tribes that may be affected by the proposed Project, the SHPO, and other appropriate parties as defined in 36 CFR § Section 800.2. Initial comments on the proposed project provided by SHPO prior to the completion of the cultural resources review are provided in Appendix G as well as SHPO correspondence regarding NRHP listing eligibility of the site on the northwest end of the proposed Project. This correspondence addresses obligations to consult with SHPO under Section 106 of the NHPA. Consultation under NHPA also included contacting tribal entities in the project. Minnkota, on behalf of RUS, has contacted tribes in the project area by letter and to-date no responses have been received.

The USFWS oversees compliance with ESA (16 U.S.C. Sections 15361–1534), which requires that federal agencies “insure that any action authorized, funded, or carried out by such agency is not likely to jeopardize the continued existence of any listed species or result in the destruction or adverse modification of critical habitat of such species.” Minnkota, on behalf of the RUS, has consulted with the USFWS regarding the potential for adverse effects and has received concurrence that the proposed project will not adversely affect federally listed species.

7.3 Identification of Landowners

A list of landowners is included in Appendix D. Addresses have been redacted from the landowner list due to privacy concerns. Minnkota has contacted landowners and is in the process of securing easement options.

7.4 Required Permits and Approvals

In addition to a Route Permit, other federal, state, and local permits could potentially be required for the proposed Project. These are identified below in Table 16.

Table 16 Potential Permits Required

| Permit | Jurisdiction |
|--|-------------------|
| Federal | |
| NEPA Environmental Review | RUS |
| State | |
| Route Permit | MPUC |
| Utility Permit | MnDOT |
| PWI Crossing Permit | MnDNR |
| NPDES Construction Stormwater Permit | MPCA |
| Local | |
| Minnesota Wetland Conservation Act Certification | Clearwater County |

For the other permits listed in Table 16, and any additional permit requirements identified during subsequent agency consultations, the Applicant will acquire the necessary authorizations and develop the appropriate plans associated with any permit or authorization (e.g., stormwater pollution prevention management plan prior to construction).

7.4.1 Federal Permits

7.4.1.1 U.S. Army Corps of Engineers

The U.S. Army Corps of Engineers (ACOE) regulates the placement of fill material into wetlands that are located adjacent to, or hydraulically connected to, interstate or navigable waters under the authority of Section 404 of the Clean Water Act. No pole placement or fill will occur within wetlands as a result of the

proposed Project, therefore a permit will not be required from ACOE. In the unanticipated event that a pole or fill is placed in a wetland as a result of the proposed Project, it will likely fall under a non-reporting utility line discharge provision of a Regional General Permit (RGP-3-MN) which provides for utility line discharges. Notification will be required if the proposed Project will cross more than 500 feet of wetland and require direct fill for placement of structures in wetlands.

7.4.2 State of Minnesota Permits

7.4.2.1 Minnesota Public Utilities Commission

Minn. Stat. § 216E.03, subd. 2, provides that no person may construct a HVTL without a Route Permit from the Commission. The Applicant is seeking a Route Permit from the Commission with this Application.

7.4.2.2 Minnesota Department of Natural Resources

The MnDNR Division of Lands and Minerals regulates utility crossings on, over or under any state land or public water identified on the Public Waters and Wetlands Maps. A license to cross Public Waters is required under Minn. Stat. § 84.415 and Minn. R., chapter 6135. The MnDNR Division of Waters requires a Public Waters Work Permit for any alteration of the course, current, or cross-section below the ordinary high water level of a Public Water or Watercourse. MnDNR comments on the proposed project are included in Appendix G.

7.4.2.3 Minnesota Pollution Control Agency

MPCA requires an NPDES construction storm water permit and SWPPP for owners or operators for any construction activity disturbing: 1) one acre or more of soil; 2) less than one acre of soil if that activity is part of a "larger common plan of development or sale" that is greater than one acre. The MPCA may also require the proposed Project to have an individual NPDES/SDS construction storm water permit. Most construction activities are covered by the general NPDES storm water permit for construction activity. Individual NPDES/SDS permits may be required for very large projects or projects that have a high potential to impact environmentally sensitive areas. The Applicant will determine if their project exceeds the one acre threshold, and, if so, obtain the permit or notice of permit coverage from the MPCA. The MPCA would notify the Applicant if they will need to obtain an individual NPDES/SDS permit for their project.

7.4.3 Local Permits

Once the Commission issues a Route Permit, zoning, building and land use regulations and rules are preempted per Minn. Stat. § 216E.10, subd. 1. Applicable permits from Clearwater County concerning road access, road ROW, and wetlands under Minnesota Wetland Conservation Act (WCA) will be secured as needed for the proposed Project. Clearwater County's comments on the proposed project are included in Appendix G.

8.0 References

- [1] Minnesota Department of Health, "EMF White Paper on Electric and Magnetic Field (EMF) Policy and Mitigation Options," 2002.
- [2] Natural Resource Council, "Possible Health Effects of Exposure to Residential Electric and Magnetic Fields," 1997.
- [3] NIEHS. [Online]. Available: www.niehs.nih.gov/health/topics/agents/emf/.
- [4] Minnesota Department of Natural Resources, "Minnesota Department of Natural Resources Ecological Classification System," July 2014. [Online]. Available: <http://www.dnr.state.mn.us/ecs/index.html>. [Accessed July 2014].
- [5] Minnesota Pollution Control Agency, "A Guide to Noise Control in Minnesota," 2008. [Online]. Available: <http://www.pca.state.mn.us/index.php/view-document.html?gid=5355>.
- [6] <http://quickfacts.census.gov/qfd/states/27/27029.html> [Accessed July 2014].
- [7] Wikipedia, "Clearbrook, Minnesota," 2014. [Online]. Available: http://en.wikipedia.org/wiki/Clearbrook,_Minnesota
- [8] Census Data, "Clearbrook City Data," [Online]. Available: <http://www.city-data.com/city/Clearbrook-Minnesota.html>. [Accessed July 2014].
- [9] U.S. Environmental Protection Agency, "Currently Designated Nonattainment Areas for Critical Pollutants," 2012. [Online]. Available: <http://www.epa.gov/oaqps001/greenbk/ancl.html>.
- [10] Federal Emergency Management Agency, *FEMA Q3 Floodways*, 2003.
- [11] Minnesota Department of Natural Resources, *GAP Land Cover. GIS shapefile*, 2002.
- [12] Avian Power Line Interaction Committee, *Suggested Practices for Avian Protection on Power Lines: The State of the Art in 2006*, Washington, D.C. and Sacramento, CA: Edison Electric Institute, APLIC, and the California Energy Commission, 2006.
- [13] United States Fish and Wildlife Service, "County Distribution of Minnesota's Federally Threatened, Endangered, and Candidate Species," 2014. [Online]. Available: <http://www.fws.gov/midwest/endangered/lists/minnesot-cty.html>. [Accessed July 2014]

9.0 Definitions

Following are a list of definitions used in this Application:

| | |
|-------------------------------------|---|
| Avian | Of or relating to birds. |
| A-weighted Scale | The sensitivity range for human hearing. |
| Breaker | Device for opening a circuit. |
| Bus | An electrical conductor that serves as a common connection for two or more electrical circuits; may be in the form of rigid bars or stranded conductors or cables. |
| Conductor | A material or object that permits an electric current to flow easily. |
| Corona | The breakdown or ionization of air in a few centimeters or less immediately surrounding conductors. |
| Double-circuit | The construction of two separate circuits at the same or different voltage on the same structures to increase capacity of the line. |
| Electric Field (EF) | The field of force that is produced as a result of a voltage charge on a conductor or antenna. |
| Electromagnetic | The term describing the relationship between electricity and magnetism; a quality that combines both magnetic and electric properties. |
| Electromagnetic Fields (EMF) | The term EMF refers to electric and magnetic fields that are coupled together, such as in high frequency radiating fields. For the lower frequencies associated with power lines, EMF should be separated into electric and magnetic fields. Electric and magnetic fields arise from the flow of electricity and the voltage of a line. The intensity of the electric field is related to the voltage of the line. The intensity of the magnetic field is related to the current flow through the conductors. |

| | |
|---|---|
| Excavation | A cavity formed by cutting, digging, or scooping. |
| Fauna | The collective animals of any place or time that live in mutual association. |
| Flora | The collective plants of any place or time that live in mutual association. |
| Grading | To level off to a smooth horizontal or sloping surface. |
| Grounding | To connect electrically with a ground. |
| Habitat | The place or environment where a plant or animal naturally or normally lives and grows. |
| High Voltage Transmission Lines (HVTL) | Overhead and underground conducting lines of either copper or aluminum used to transmit electric power over relatively long distances, usually from a central generating station to main substations. They are also used for electric power transmission from one central station to another for load sharing. High voltage transmission lines typically have a voltage of 69 kV or more. |
| Hydrocarbons | Compounds that contain carbon and hydrogen, found in fossil fuels. |
| Ionization | Removal of an electron from an atom or molecule. The process of producing ions. The electrically charged particles produced by high-energy radiation, such as light or ultraviolet rays, or by the collision of particles during thermal agitation. |
| Magnetic Field (MF) | The region in which the magnetic forces created by a permanent magnet or by a current-carrying conductor or coil can be detected. The field that is produced when current flows through a conductor or antenna. |
| Mitigate | To lessen the severity of or alleviate the effects of. |

| | |
|--|--|
| Neutral to Earth Voltage (NEV) | The term NEV is used to describe a measurable level of voltage which may occur between a metal object and the adjacent floor or earth. |
| Oxide | A compound of oxygen with one other more positive element or radical. |
| Ozone | A form of oxygen in which the molecule is made of three atoms instead of the usual two. |
| Raptor | A member of the order Falconiformes, which contains the diurnal birds of prey, such as the hawks, harriers, eagles and falcons. |
| Sediment | Material deposited by water, wind, or glaciers. |
| Scientific and Natural Area | A program administered by the MnDNR with the goal to preserve and perpetuate the ecological diversity of Minnesota’s natural heritage, including landforms, fossil remains, plant and animal communities, rare and endangered species, or other biotic features and geological formations, for scientific study and public edification as components of a healthy environment. |
| Site of Biodiversity Significance | The Minnesota County Biological Survey collects baseline data on the distribution and ecology of native plant communities. At the conclusion of the work, the MCBS assigns a biodiversity significance rank to each site surveyed. |
| Stray Voltage | “Stray voltage” is a condition that can occur on the electric service entrances to structures from distribution lines, not transmission lines. More precisely, stray voltage is a voltage that exists between the neutral wire of the service entrance and grounded objects in buildings such as barns and milking parlors. Transmission lines do not, by themselves, create stray voltage because they do not connect to businesses or residences. Transmission lines, however, can induce stray voltage on a distribution circuit that is parallel to and immediately under the transmission line. |

| | |
|--|---|
| Substation | A substation is a high voltage electric system facility. It is used to switch generators, equipment, and circuits or lines in and out of a system. It also is used to change AC voltages from one level to another. Some substations are small with little more than a transformer and associated switches. Others are very large with several transformers and dozens of switches and other equipment. |
| Ultraviolet Radiation | A portion of the electromagnetic spectrum with wavelengths shorter than visible light. |
| Voltage | Electric potential or potential difference expressed in volts. |
| Waterfowl | A bird that frequents water; especially a swimming game bird (as a duck or goose) as distinguished from an upland game bird or shorebird. |
| Waterfowl Production Area (WPA) | Waterfowl Production Areas preserve wetlands and grasslands critical to waterfowl and other wildlife. These public lands, managed by the U.S. Fish and Wildlife Service, were included in the National Wildlife Refuge System in 1966 through the National Wildlife Refuge Administration Act. |
| Wetland | Wetlands are areas that are periodically or permanently inundated by surface or ground water and support vegetation adapted for life in saturated soil. Wetlands include swamps, marshes, bogs and similar areas. |
| Wildlife Management Area (WMA) | Wildlife Management Areas are part of Minnesota's outdoor recreation system and are established to protect those lands and waters that have a high potential for wildlife production, public hunting, trapping, fishing and other compatible recreational uses. |

10.0 Acronyms

| | |
|------------------------------|--|
| AC | Alternating Current |
| ACOE | U.S. Army Corps of Engineers |
| ALJ | Administrative Law Judge |
| Applicant | Minnkota Power |
| Application | Route Permit Application |
| Barr | Barr Engineering Company |
| BMP | Best Management Practice |
| BPA | Bonneville Power Administration |
| Brookings Project Commission | Brookings County – Hampton 345 kV Route Permit proceeding |
| Company | Minnesota Public Utilities Commission |
| Company | Northern States Power Company |
| dBa | A-weighted sound level in decibels |
| DC | Direct Current |
| ECS | Ecological Classification System |
| EF | Electric Field |
| ELF | Extremely Low Frequency |
| EMF | Electric and Magnetic Fields |
| FAA | Federal Aviation Administration |
| FEMA | Federal Emergency Management Agency |
| GAP | Gap Analysis Program |
| GIS | Geographic Information System |
| HVTL | High Voltage Transmission Line |
| kV | Kilovolt |
| kV/m | Kilovolts Per Meter |
| L | Level Descriptors or Statistical Sound Levels |
| L ₁₀ | the dBA that may be exceeded 10 percent of the time within an hour |
| L ₅₀ | the dBA that may be exceeded 50 percent of the time within an hour |
| LGU | Local Government Unit |
| MCBS | Minnesota County Biological Survey |
| MF | Magnetic Field |
| mG | milliGauss |
| MnDNR | Minnesota Department of Natural Resources |
| MnDOT | Minnesota Department of Transportation |
| MPCA | Minnesota Pollution Control Agency |
| MPUC | Minnesota Public Utilities Commission |
| NAC | Noise Area Classification |
| NESC | National Electric Safety Code |
| NEV | Neutral to Earth Voltage |
| NHIS | National Heritage Information System |
| NIEHS | National Institute of Environmental Health Sciences |
| NPDES | National Pollutant Discharge Elimination System |
| NRHP | National Register of Historic Places |
| NWI | National Wetlands Inventory |
| ppm | parts per million |
| PPSA | Power Plant Siting Act |
| Project | Minnkota Power Clearbrook HVTL Project |

| | |
|---------------|--|
| PWI | MnDNR Public Water Inventory |
| RGP | Regional General Permit |
| SHPO | Minnesota State Historic Preservation Office |
| SBS | Site of Biodiversity Significance |
| SNA | Scientific and Natural Area |
| SWPPP | Stormwater Pollution Prevention Plan |
| USFWS | United States Fish and Wildlife Service |
| VOR | Very-High-Frequency Omni-Directional Range |
| WCA | Wetland Conservation Act |
| WMA | Wildlife Management Area |
| Working Group | Interagency Working Group |
| WPA | Waterfowl Production Area |

Appendix A

Applicant's Notice Letter to Commission of Intent to Use Alternative Permitting Process

P.O. Box 13200 • Grand Forks, ND 58208-3200
1822 Mill Road • Grand Forks, ND 58203
August 5, 2014

Phone (701) 795-4000
www.minnkota.com

VIA ELECTRONIC FILING

Dr. Burl W. Haar
Executive Secretary
Minnesota Public Utilities Commission
121 Seventh Place East, Suite 350
St. Paul, MN 55101

Re: Notification of Intent to File Route Permit Application Under the Alternative Permitting Process for the Clearbrook - Clearbrook West 115 kilovolt transmission line Clearwater County, MN Minnkota Power Cooperative, Inc.

Dear Dr. Harr

In accordance with Minn. Rules 7850.2800, subp. 2, Minnkota Power Cooperative, Inc. ("Minnkota Power") hereby notifies the Minnesota Public Utilities Commission (MPUC) of its intent to submit an application for a route permit for the Clearbrook – Clearbrook West Project (Project) pursuant to the alternative permitting procedures in Minn. Rules 7850.2800 to 7850.3900.

The proposed project includes construction of a new 5.3-mile long, 115 kilovolt (kV) electric transmission and a new 115/4.16 kV substation. The proposed project will start in Leon Township by tapping an existing 115 kV line via construction of a 1-way line switch and the proposed project will end in Pine Lake Township at the new 115/4.16 kV substation (Figure 1). The proposed Project is needed to serve a single industrial in the Clearbrook, Minnesota area.

Minnkota Power plans to file the application in August 2014 and will work with the MPUC and Department of Commerce staff to address any questions and/or comments in order to expedite the application's acceptance and completion of the environmental assessment.

If you have any questions or concerns, I can be reached by email at jgraves@minnkota.com or by phone at (701) 795-4221.

Sincerely,



John T. Graves, P.E.
Environmental Manager
Minnkota Power Cooperative, Inc.

Enclosure: Figure 1

c: Service List
Jay Bushy
Louise L. Segroves – Barr Engr.

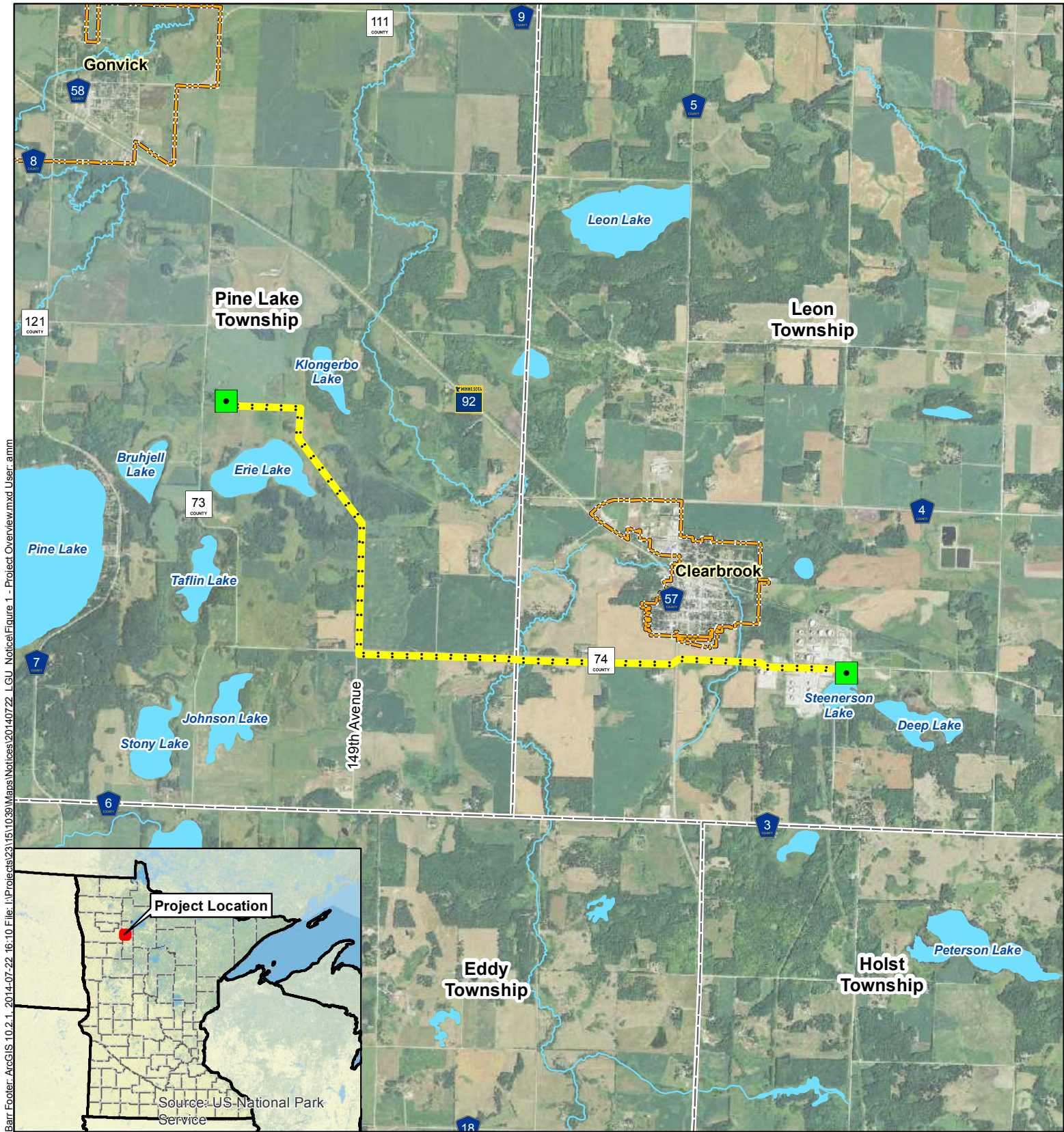

Barr Footer: ArcGIS 10.2.1, 2014-07-22 16:10 File: I:\Projects\23151\1039\Maps\notices\20140722_LGU_Notice\Figure 1 - Project Overview.mxd User: ammm

Image Source: 2013 Farm Service Agency

- Approximate Substation Location
- Proposed Clearbrook 115 kV
- Municipal Boundary
- Township Boundary
- PWI Watercourse
- PWI Basin

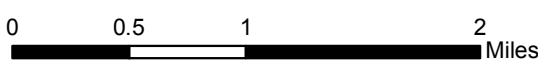

Figure 1

PROJECT OVERVIEW
 Proposed Clearbrook West
 115 kV HVTL Project
 Minnkota Power
 Clearwater County, MN

CERTIFICATE OF SERVICE

STATE OF MINNESOTA)
) ss.
COUNTY OF HENNEPIN)

AFFIDAVIT OF SERVICE VIA
ELECTRONIC FILING

Louise Segroves of the city of Minneapolis, county of Hennepin, state of Minnesota says that on the 6th day of August, 2014, she served the attached Notice of Intent in accordance with Minnesota Rules 7850.2800 Subpart 2 via electronic filing. The parties on the attached service list were served as so indicated on the list.

/s/ Louise Segroves *Louise M Segroves*

Subscribed and sworn to before me this
6th day of August, 2014.

/s/ Teresa Kes *Teresa M Kes*
Notary Public – Minnesota
My Commission Expires Jan. 31, 2015



| NameLast | NameFirst | Email | Organization | Address | Address2 | City | State | Zip | Delivery Method |
|----------------|------------------|-----------------------------------|--|--------------------------|------------|--------------|-------|-------|--------------------|
| Warner | Caren | caren.warner@state.mn.us | Minnesota Department of Commerce | | | | | | Electronic Service |
| Thayer | Jayne | jthayer@rockfordconstruction.com | | | | | MI | | Electronic Service |
| Krause | Kari | kari_krause@yahoo.com | AMEC Earth and Environmental | | | | MN | | Electronic Service |
| Purkis | Jack | john.purkis@state.mn.us | | | | | | | Electronic Service |
| Southern | Karen | karensouthern@hotmail.com | | | | | MN | | Electronic Service |
| Johnson | Scott | scott.johnson@ci.medina.mn.us | | | | | MN | | Electronic Service |
| Mattison | Michael | mmm123usa@gmail.com | | | | | MN | | Electronic Service |
| Woodland | Tim | vtwvtv@gmail.com | | | | | MN | | Electronic Service |
| Adrian | Steve | steven.adrian@state.mn.us | | | | | MN | | Electronic Service |
| Wright-Prince | Deborah | twodogdeb@aol.com | | 19480 Shady Hills Road | | Shorewood | MN | | Electronic Service |
| Doll | Tom | noofdog@gmail.com | | P.O. Box 148 | | Excelsior | MN | | Electronic Service |
| Baker | Brian | bcbwca@gmail.com | | 7176 Arrowhead Ct. | | Chanhassen | MN | | Electronic Service |
| Berg | Dan | drberg1@yahoo.com | | 7166 Arrowhead Court | | Chanhassen | MN | | Electronic Service |
| Bauer | Brent | brent@steelfabusa.com | | | | | MN | | Electronic Service |
| Ngu | Michael | mngu66@gmail.com | | 7822 Donegal Cove | | Eden Prairie | MN | | Electronic Service |
| Kalal | Mark | mdkalal@gmail.com | | | | | MN | | Electronic Service |
| Krantz | Patty | patty.krantz@yahoo.com | | 7893 Bailey Drive | | Eden Prairie | MN | | Electronic Service |
| Smetana | Tracy | tracy.smetana@state.mn.us | Public Utilities Commission | | | | MN | | Electronic Service |
| McInnis | Ryan | rjmcinnis@gmail.com | | | | | MN | | Electronic Service |
| vanLingen | Hans | hans.vanlingen@enel.com | Enel Green Power North America Inc. | 1 Tech Drive | Suite 220 | Andover | MA | 1810 | Electronic Service |
| Barenholtz | Jan | jbaren@aol.com | | 67 Waterville Road | | Southport | CT | 6890 | Electronic Service |
| Whieldon | Esther | ewhieldon@snl.com | SNL ENergy | 1700 North Moore Street | Suite 1110 | Arlington | VA | 22209 | Electronic Service |
| Meyer | Beatrice | balm38@yahoo.com | | 3284 Clairmont North NE | | Atlanta | GA | 30329 | Electronic Service |
| Abrams | Lonnie | lonabrams@yahoo.com | | 280 Zandale Drive | | Lexington | KY | 40503 | Electronic Service |
| Porter | Timothy | TPORTER@REYNOLDSINC.COM | Reynolds Inc. | 6360 Huntley Road | | Columbus | OH | 43229 | Electronic Service |
| Strohm | Carl | cjsmg@sbcglobal.net | | 8318 Hi-Vu Drive | | Indianapolis | IN | 46227 | Electronic Service |
| VanHaren | John | john@nationalpoleandstructure.com | National Pole and Structure | 9428 Talladay Road | | Willis | MI | 48191 | Electronic Service |
| Baruth | Dale | stscbaruth@hotmail.com | | 111 W 1st Ave N | | Estherville | MN | 51334 | Electronic Service |
| Tadych | Todd | ttadych@atcllc.com | American Transmission Company LLC | 2 Fen Oak Court | | Madison | WI | 53718 | Electronic Service |
| Hanson | Linda | | | W 1806 Wilson Rd | | Hawkins | WI | 54530 | Paper Service |
| Wolf | Guy | | Board Member of Clean Wisconsin | N3421 Mohawk Valley Road | | Stoddard | WI | 54658 | Paper Service |
| King | Bruce | bruce@ranww.org | Realtors Association of Northwestern Wisconsin | 1903 Keith Street | Suite 3 | Eau Claire | WI | 54701 | Electronic Service |
| Scriven | Terri | tscriven@rvtcorp.com | River Valley Testing Corp | 1060 Breezewood Lane | Suite 102 | Neenah | WI | 54956 | Electronic Service |
| Bodeker | Ricky and Connie | bbfai@frontiernet.net | | 6842 338th Street Way | | Cannon Falls | MN | 55009 | Electronic Service |
| Stark | Deborah | cftownship@frontiernet.net | Cannon Falls Township | 30715 Woodhaven Trail | | Cannon Falls | MN | 55009 | Electronic Service |
| McMorrow | Michelle | michellemcmorrow@yahoo.com | | 32537 59th Avenue Way | | Cannon Falls | MN | 55009 | Electronic Service |
| Adelmann | Audrey | peteadelmann@yahoo.com | | 4752 220th St. W. | | Farmington | MN | 55024 | Electronic Service |
| Eide-Tollefson | Kristen | NA | | POB 129 | | Frontenac | MN | 55026 | Paper Service |
| Marshman | Joan | marshman1@hotmail.com | Florence Township | 30129 Co 2 Blvd | PO Box 62 | Frontenac | MN | 55026 | Electronic Service |
| Passe | Daniel | dbpasse@embarqmail.com | | 23611 Belmont Street | | Hampton | MN | 55031 | Electronic Service |
| Nicolai | Leo | nicolairepair@embarqmail.com | | 23449 Lewiston Blvd. | | Hampton | MN | 55031 | Electronic Service |
| Radford | Sam | be682@msn.com | | 23305 Hampton Blvd. | | Hampton | MN | 55031 | Electronic Service |
| Enedy | Robert | renedy@msn.com | | 23076 Lewiston Blvd | | Hampton | MN | 55031 | Electronic Service |
| Anderson | Sigurd | mariner@eldinc.com | CURE | PO Box 278 | | Lake City | MN | 55041 | Electronic Service |
| Crocker | George | NA | North American Water | PO Box 174 | | Lake Elmo | MN | 55042 | Paper Service |
| Erickson | Mike | mike@scrupleshaircare.com | Scruples Professional Salon Products Inc. | 8231 214th St. W. | | Lakeville | MN | 55044 | Electronic Service |
| Palmquist | Mark | mstp@sei.cmu.edu | | 24831 Natchez Avenue | | Lakeville | MN | 55044 | Electronic Service |
| Fredrickson | Dale | | | 12406 347th St. | | Lindstrom | MN | 55045 | Paper Service |
| Miller | Dianne | dimiller55@means.net | | 8652 60th Street West | | Lonsdale | MN | 55046 | Electronic Service |
| Zimanske | Betty | bettyz@means.net | | 5710 Halstad Avenue | | Lonsdale | MN | 55046 | Electronic Service |
| Henry | Kris | kris.henry@northfieldwifi.com | | 28441 Garrett Avenue | | Northfield | MN | 55057 | Electronic Service |
| Vorwerk | Larry | ljvorwerk@yahoo.com | | 29322 Danbury Ave. | | Northfield | MN | 55057 | Electronic Service |
| Collins | Andy | ru4longboarding@yahoo.com | | 4688 290th Street West | | Northfield | MN | 55057 | Electronic Service |
| Edwards | Patrick | kared@myclearwave.net | | 10006 305th Street West | | Northfield | MN | 55057 | Electronic Service |
| Rowan | Tony and Shelley | o_hogwash@yahoo.com | | 30800 Iran Path | | Northfield | MN | 55057 | Electronic Service |

| NameLast | NameFirst | Email | Organization | Address | Address2 | City | State | Zip | Delivery Method |
|------------|-------------------|----------------------------------|--|--------------------------------|---------------------------|---------------------|-------|-------|--------------------|
| Patrick | Bonnie | | | 30875 MN Ave | | Lindstrom | MN | 55065 | Paper Service |
| Dick | Barbara | barbara@powersys.com | | 29155 Harry Ave | | Randolph | MN | 55065 | Electronic Service |
| Overland | Carol | overland@legalelectric.org | Overland Law Office | 1110 West Ave | | Red Wing | MN | 55066 | Electronic Service |
| Lindquist | Kim | NA | City of Rosemount | 2875 145th Street W | | Rosemount | MN | 55068 | Paper Service |
| Simon | Cyril and Natalie | cynat@bevcomm.net | | 2646 260th St. East | | Webster | MN | 55088 | Electronic Service |
| Geibe | Jayne | ninjetta@msn.com | | 4925 Elmore Ave | | Webster | MN | 55088 | Electronic Service |
| Birkholz | David | david.birkholz@state.mn.us | Minnesota Department of Commerce | 85 7th Place East | Suite 500 | Saint Paul | MN | 55101 | Electronic Service |
| Pile | Deborah | deborah.pile@state.mn.us | Minnesota Department of Commerce Energy Facility Permitting Siting and Routing | 85 7th Place East | Suite 500 | St. Paul | MN | 55101 | Electronic Service |
| Smetana | Tracy | consumer.puc@state.mn.us | Consumer Affairs Office | MN Public Utilities Commission | 121 7th Place E Suite 350 | St. Paul | MN | 55101 | Electronic Service |
| Olsen | Cheryl | cheryl.olsen@metc.state.mn.us | Metropolitan Council | 390 Robert ST N | | St. Paul | MN | 55101 | Electronic Service |
| Ek | Scott | scott.ek@state.mn.us | Minnesota Department of Commerce. Energy Facility Permitting Siting and Routing | 85 7th Place East | Suite 500 | St. Paul | MN | 55101 | Electronic Service |
| DeBleekere | Tricia | tricia.debleekere@state.mn.us | MN Public Utilities Commission | 121 7th Place East | Suite 350 | St. Paul | MN | 55101 | Electronic Service |
| O Connell | Kate | kate.oconnell@state.mn.us | | 85 7th Place East | Suite 500 | St. Paul | MN | 55101 | Electronic Service |
| Kaluzniak | Michael | mike.kaluzniak@state.mn.us | MPUC | 121 7th Place East | Suite 350 | St. Paul | MN | 55101 | Electronic Service |
| Larsen | Jim | jim.larsen@metc.state.mn.us | Metropolitan Council | 390 Robert ST N | | Saint Paul | MN | 55101 | Electronic Service |
| Van Thomme | Hannah | hannah.van.thomme@state.mn.us | PUC | none | none | St. Paul | MN | 55101 | Electronic Service |
| Swanson | Eric | NA | Winthrop and Weinstine P.A. | 225 South Sixth Street | Suite 3500 | Minneapolis | MN | 55102 | Paper Service |
| Koen | Charles | charles_koen@msn.com | | 360 Spring St. 432 | | St Paul | MN | 55102 | Electronic Service |
| Rucolo | Erin Stojan- | rucolo@fresh-energy.org | Fresh Energy | 408 St. Peter Street | Suite 220 | St. Paul | MN | 55102 | Electronic Service |
| Nyhus | Steven | swnyhus@flaherty-hood.com | Flaherty and Hood P.A. | 525 Park St | Suite 470 | St. Paul | MN | 55103 | Electronic Service |
| Garletz | Annalee | garletz@mncounties.org | Association of MN Counties | 125 Charles Avenue | | St. Paul | MN | 55103 | Electronic Service |
| Macabee | Paula | pmaccabec@visi.com | Just Change Consulting Law Offices | 1961 Selby | EMAIL ONLY | St. Paul | MN | 55104 | Electronic Service |
| Doperalski | Melissa | melissa.doperalski@state.mn.us | DNR | 1200 Warner Road | | St. Paul | MN | 55106 | Electronic Service |
| Myren | David | david.myren@aseholdings.com | Aero Systems Engineering Inc. | 358 East Fillmore Avenue | | St. Paul | MN | 55107 | Electronic Service |
| Mitchell | Brian | bmittchell@corvalgroup.com | Corval Group | 1633 Eustis Street | | St. Paul | MN | 55108 | Electronic Service |
| Kaufman | Todd | tkaufman@wellingtonmgt.com | Wellington Management Inc. | 1625 Energy Park Drive | Suite 100 | St. Paul | MN | 55108 | Electronic Service |
| Klier | Jake | jake_klier@yahoo.com | | 3456 Savannah Ave | | White Bear Lake | MN | 55110 | Electronic Service |
| Wazlawik | John | banzaibiker@q.com | | 5242 Lakeview Ave | | White Bear Township | MN | 55110 | Electronic Service |
| Finn | Huck | NA | API Construction Company | 1100 Old Hwy 8 N.W. | | New Brighton | MN | 55112 | Paper Service |
| Sherman | Todd | NA | Dept. of Transportation | Waters Edge | 1500 W. Co. Rd. B2 | Roseville | MN | 55113 | Paper Service |
| Kromar | Karen | karen.kromar@state.mn.us | MPCA | 520 Lafayette Road North | 4th Floor | St. Paul | MN | 55116 | Electronic Service |
| Stuelpner | Alan | stuelpner@comcast.net | | 1101 Sibley Memorial Hwy 413 | | St Paul | MN | 55118 | Electronic Service |
| Coates | Becky | becky.coates@psiusa.com | Professional Service Industries Inc. | 2401 Pilot Knob Road | Suite 138 | Mendota Heights | MN | 55120 | Electronic Service |
| Long | Brian | brian.long@ulteig.com | Ulteig Engineering Inc. | 4285 Lexington Ave N | | St Paul | MN | 55126 | Electronic Service |
| Koebrick | Andrew | andrew.koebrick@state.mn.us | Minnesota Department of Administration Office of Geographic and Demographic Analysis Minnesota Geospatial Information Office | 658 Cedar | 300 COB | St. Paul | MN | 55155 | Electronic Service |
| Kotch | Stacy | stacy.kotch@state.mn.us | Minnesota Department of Transportation | 395 John Ireland Blvd | Mailstop 678 | St. Paul | MN | 55155 | Electronic Service |
| | | NA | Forum Communications | Pressroom B12C | State Capitol | St. Paul | MN | 55155 | Paper Service |
| Doucette | Elise | elise.doucette@pca.state.mn.us | Minnesota Pollution Control Agency | 520 Lafayette Road North | | St. Paul | MN | 55155 | Electronic Service |
| Schrenzel | Jamie | jamie.schrenzel@state.mn.us | MN DNR | 500 Lafayette Road | Box 25 | St. Paul | MN | 55155 | Electronic Service |
| Jensen | Patrice | patrice.jensen@state.mn.us | MPCA | 520 Lafayette Road | | St. Paul | MN | 55155 | Electronic Service |
| Rieck | Christian | christian@christianriec.com | | 2819 167th Lane NW | | Andover | MN | 55304 | Electronic Service |
| Hartman | Larry | hartman.larry@gmail.com | | 2236 Sherwood Court | | Minnetonka | MN | 55305 | Electronic Service |
| DeSalle | Pam | pjholman@frontiernet.net | | P.O. Box 142 | | Becker | MN | 55308 | Electronic Service |
| Hreha | Jodi | elfe0012@umn.edu | | 8315 Shadyview Lane N | | Maple Grove | MN | 55311 | Electronic Service |
| MacLeod | Valerie | vcmac4@yahoo.com | | 2710 Longacres Dr. | | Chanhassen | MN | 55317 | Electronic Service |
| Griese | Patti | p.griese@mchsi.com | | 6800 Highover Drive | | Chanhassen | MN | 55317 | Electronic Service |
| Conti | Stacy | craigstacyethan@gmail.com | | 2580 Highcrest Circle | | Chanhassen | MN | 55317 | Electronic Service |
| Tran | Hau | hau.x.tran@gmail.com | | 6927 Highover CT N | | Chanhassen | MN | 55317 | Electronic Service |
| Steele | Ingrid | ingridandjonsteele@msn.com | | 6941 Highover Court No | | Chanhassen | MN | 55317 | Electronic Service |
| Clarey | Mark | mclarey@northcotthospitality.com | Northcott Hospitality LLC | 250 Lake Drive East | | Chanhassen | MN | 55317 | Electronic Service |
| Bentley | Thomas | tb3bars69@yahoo.com | | 5250 CR 140 | | CHASKA MN USA | MN | 55318 | Electronic Service |

| NameLast | NameFirst | Email | Organization | Address | Address2 | City | State | Zip | Delivery Method |
|-------------|---------------|------------------------------------|---|----------------------------|---------------------|-----------------------|-------|------------|--------------------|
| McCurry | Stephen | smccurry@visi.com | | 1320 Wildflower Lane | | Chaska | MN | 55318 | Electronic Service |
| Bubb | Steven | stevebubb@gmail.com | Energy Pursuits LLC | 261 School Avenue | Suite 200 | Excelsior | MN | 55331 | Electronic Service |
| Noonan | Daniel | denoonan20@msn.com | | 21115 Radisson Road | | Excelsior | MN | 55331 | Electronic Service |
| Stockdale | David | dazzlemn@gmail.com | | 7210 Galpin Blvd | | Excelsior | MN | 55331 | Electronic Service |
| Black | Chris | cjbljb@gmail.com | | 49630 660th Ave | | Fairfax | MN | 55332 | Electronic Service |
| Henry | Robert | rhenry@tcwr.net | | 2925 12th Street East | | Glencoe | MN | 55336 | Electronic Service |
| Goff | Wayne | goffwe@earthlink.net | Homeowner | 5721 Highway 212 | | Glencoe | MN | 55336 | Electronic Service |
| Hunstad | Tim | timhunstad@hotmail.com | HMG LLC | 4165 Shorewood Trail | | Medina | MN | 55340 | Electronic Service |
| Ehlen | Timothy | ehlen@mchsi.com | NWEC | 2750 Capriole Drive | | Medina | MN | 55340 | Electronic Service |
| Buckalew | Adam | ajbuckalew@yahoo.com | | 3295 Butternut Dr | | Medina | MN | 55340 | Electronic Service |
| Beckmann | Dale | dale.beckmann@westwoodps.com | Westwood | 7699 Anagram Dr. | | Eden Prairie | MN | 55344 | Electronic Service |
| Gorshe | Dawn | dgorshe@iret.com | IRET Properties | 10050 Crosstown Circle | Suite 105 | Eden Prairie | MN | 55344 | Electronic Service |
| Hultgren | Mike | michael.hultgren@westwoodps.com | Westwood Professional Services | 7699 Anagram Drive | | Eden Prairie | MN | 55344-7310 | Electronic Service |
| Gordon | Loren | lgordon@eminnetonka.com | City of Minnetonka | 14600 Minnetonka Blvd. | | Minnetonka | MN | 55345 | Electronic Service |
| Pangborn | Michael | michael.pangborn@nexteraenergy.com | NextEra Energy Resources | 14000 Sundial Ct | | Eden Prairie | MN | 55346 | Electronic Service |
| Tritch | Tim and Kelly | kellytritch@gmail.com | | 18304 Coneflower Lane | | Eden Prairie | MN | 55346 | Electronic Service |
| Heim | Kevin | kevsuealex@aol.com | | 9169 Larkspur Lane | | Eden Prairie | MN | 55347 | Electronic Service |
| Max | Jennifer | jennifer.max@hotmail.com | | 17612 George Moran Drive | | Eden Prairie | MN | 55347 | Electronic Service |
| Afable | Pedro | peds.3rd@gmail.com | | 7835 Dover Cove | | Eden Prairie | MN | 55347 | Electronic Service |
| Lee | Jung | aekyoung@gmail.com | | | | | MN | 55347 | Electronic Service |
| Skaar | Debra | skaar006@umn.edu | University of Minnesota | 17545 George Moran Drive | | Eden Prairie | MN | 55347 | Electronic Service |
| Klouda | Tim | tklouda2@msn.com | | 17023 Terrey Pine Drive | | Eden Prairie | MN | 55347 | Electronic Service |
| Nielsen | Cathy | cathnielsen@me.com | | 7803 Bailey Drive | | Eden Prairie | MN | 55347 | Electronic Service |
| Fristed | Glenn | lawranger2@q.com | | 17247 Terrey Pine Drive | | Eden Prairie | MN | 55347 | Electronic Service |
| Martin | Kim | kimmartin53@comcast.net | | 17119 Terrey Pine Drive | Eden Prairie | | MN | 55347-1166 | Electronic Service |
| Jewett | Stephanie | syjewett@aol.com | | 17131 Terrey Pine Dr. | | Eden Prairie | MN | 55347-1166 | Electronic Service |
| Hickey | Douglas | dhickeymn@yahoo.com | | 4301 Spruce Way | | Maple Plain | MN | 55359 | Electronic Service |
| Mueller | Michael | mikemousse@frontiernet.net | RE MAX Advantage Plus | 2997 Bluffs Drive | | Mound | MN | 55364 | Electronic Service |
| Allison | Chuck | callis2@embarqmail.com | | 317 East Elm Street | | Norwood Young America | MN | 55368 | Electronic Service |
| Ambrose | Robert | bambrose@greenergy.com | Great River Energy | 12300 Elm Creek Blvd | | Maple Grove | MN | 55369 | Electronic Service |
| Strohufus | Mark | MStrohufus@GREnergy.com | Great River Energy | 12300 Elm Creek Blvd. | | Maple Grove | MN | 55369 | Electronic Service |
| Steckelberg | Michael | msteckelberg@greenergy.com | Great River Energy | 12300 Elm Creek Blvd. | | Maple Grove | MN | 55369 | Electronic Service |
| Schultz | Bart | bschultz@houstonengineeringinc.com | Houston Engineering Inc. | 6901 East Fish Lake Road | Suite 140 | Maple Grove | MN | 55369 | Electronic Service |
| Hansen | Eric | NA | Pinnacle Engineering Inc. | 11541 95th Avenue North | | Maple Grove | MN | 55369 | Paper Service |
| Porter | Jay | jporter@greenergy.com | Great River Energy | 12300 Elm Creek Blvd. | | Maple Grove | MN | 55369 | Electronic Service |
| Kramka | Larry | lkramka@houstoneng.com | Houston Engineering | 6901 E Fish Lake Rd | Suite 140 | Maple Grove | MN | 55369 | Electronic Service |
| Dufault | Cal | Dufault@mchsi.com | | 14893 Wilds Pkwy. NW | | Prior Lake | MN | 55372 | Electronic Service |
| Hawks | Steven | stevetarahawks@hotmail.com | | 14818 Overlook Drive | | Savage | MN | 55378 | Electronic Service |
| Mishuk | Brian | spoofoin@mchsi.com | | 14860 Overlook Drive | | Savage | MN | 55378 | Electronic Service |
| Duehr | Jeremy | jduehr@pirnie.com | Malcolm Pirnie Inc. | 924 Vista Ridge Lane | | Shakopee | MN | 55379 | Electronic Service |
| Antony | Virginia | virginiaantony@edinarealty.com | | 1000 Superior Blvd Ste 200 | | Wayzata | MN | 55391 | Electronic Service |
| Thompson | SaGonna | NA | Xcel Energy | 414 Nicollet Mall | 5th Floor | Minneapolis | MN | 55401 | Paper Service |
| Zelenak | Brian | brian.r.zelenak@xcelenergy.com | Xcel Energy | 414 Nicollet Mall | 7th Floor | Minneapolis | MN | 55401 | Electronic Service |
| Florea | Adina | adina.r.florea@xcelenergy.com | | 414 Nicollet Mall | | Minneapolis | MN | 55401 | Electronic Service |
| Christenson | Naomi | nchristenson@merjent.com | Merjent Inc. | 800 Washington Ave. N | Suite 315 | Minneapolis | MN | 55401 | Electronic Service |
| Riveslpl | Stoei | NA | | 33 South 6th Street | Suite 4200 | Minneapolis | MN | 55402 | Paper Service |
| Brown | Andrew | brown.andrew@dorseylaw.com | Dorsey and Whitney | 50 South Sixth Street | Suite 1500 | Minneapolis | MN | 55402 | Electronic Service |
| Drawz | John | jdrawz@fredlaw.com | Fredrikson Byron P.A. | 200 South Sixth Street | Suite 4000 | Minneapolis | MN | 55402 | Electronic Service |
| Meloy | Brian | brian.meloy@leonard.com | Leonard Street and Deinard | 150 South 5th Street | Suite 2300 | Minneapolis | MN | 55402 | Electronic Service |
| Bertrand | James | james.bertrand@leonard.com | Leonard Street and Deinard | 150 South 5th Street | Suite 2300 | Minneapolis | MN | 55402 | Electronic Service |
| Drawz | John | NA | Fredrikson and Byron P.A. | 200 South Sixth Street | Suite 4000 | Minneapolis | MN | 55402 | Paper Service |
| Herring | Valerie | vherring@briggs.com | Briggs and Morgan | 2200 IDS Center | 80 South 8th Street | Minneapolis | MN | 55402 | Electronic Service |
| Slade | Dana | dana.slade@avantenergy.com | Avant Energy Services | 200 South Sixth Street | Suite 300 | Minneapolis | MN | 55402 | Electronic Service |
| Heyer | Shirley | shirleymidtownphillips@msn.com | Midtown Phillips Neighborhood Association Inc | 2426 13th Ave. S. | | Minneapolis | MN | 55404 | Electronic Service |
| Kearns | Cesia | cesia.kearns@sierraclub.org | Sierra Club | 2327 E. Franklin Ave. | Ste. 1 | Minneapolis | MN | 55406 | Electronic Service |

| NameLast | NameFirst | Email | Organization | Address | Address2 | City | State | Zip | Delivery Method |
|-------------|------------------|--|--------------------------------------|-----------------------------|---------------------------|----------------|-------|-------|--------------------|
| Morris | David | dmorris@ilsr.org | | ILSR | 2720 E 22nd St | Minneapolis | MN | 55406 | Electronic Service |
| Sulander | Mark | tedebearmark@msn.com | | 2528 38th Avenue South | | Minneapolis | MN | 55406 | Electronic Service |
| Davies | Wanda | NA | Navitas Energy | 3001 Broadway St. NE | Suite 695 | Minneapolis | MN | 55413 | Paper Service |
| Gerber | Darrell | dgerber@cleanwater.org | Clean Water Action Alliance | 308 E Hennepin Ave | | Minneapolis | MN | 55414 | Electronic Service |
| Sokolski | Adam | asokolski@iberdrolaus.com | Iberdrola Renewables | 701 4th Avenue South | Suite 1010 | Minneapolis | MN | 55415 | Electronic Service |
| Intern | | ward06counciloffice@ci.minneapolis.mn.us | | 350 South 5th Street | Room 307 City Hall | Minneapolis | MN | 55415 | Electronic Service |
| Gregory | Kelsey | kgregory@csmpcorp.net | CSM Corp | 500 Washington Ave S. | Suite 3000 | Minneapolis | MN | 55415 | Electronic Service |
| Bissonnette | Michelle | NA | HDR | 701 Xenia Ave. South | Suite 600 | Minneapolis | MN | 55416 | Paper Service |
| Piner | Angela | NA | HDR | 701 Xenia Ave. South | Suite 600 | Minneapolis | MN | 55416 | Paper Service |
| Moe | M. | fignat@comcast.net | | 2021 22nd Ave NE | | Minneapolis | MN | 55418 | Electronic Service |
| Wagner | Scott | scottw@wagnergreenhouses.com | Wagner Partners LP | 6024 Penn Ave. So. | | Minneapolis | MN | 55419 | Electronic Service |
| Markegard | Glen | gmarkegard@ci.bloomington.mn.us | City of Bloomington | Planning Division | 1800 W. Old Shakopee Road | Bloomington | MN | 55419 | Electronic Service |
| Heaney | Bill | billheaney@billheaney.com | IBEW Mn. State Council | 940 44th Ave NE | Unit 21067 | Columbia Hts | MN | 55421 | Electronic Service |
| Gale | Jeffery | jjgale@fpdpower.com | FPD Power Development | 5110 Main Street NE | | Mpls | MN | 55421 | Electronic Service |
| Olson | Elling | cal.dufault@mortenson.com | M A Mortenson Co. | 700 Meadow Lane North | | Minneapolis | MN | 55422 | Electronic Service |
| Sullins | Tony | NA | USFWS | 4101 American Blvd. E | | Bloomington | MN | 55425 | Paper Service |
| Bartell | Patrick | pbartell@volco.net | Volco | 7505 Highway 7 | | Minneapolis | MN | 55426 | Electronic Service |
| Miner | Ryan | rminer@marcyconstruction.com | Marcy Construction | 2246 Edgewood Ave. | | St. Louis Park | MN | 55426 | Electronic Service |
| Hegerle | Becky | bhegerle@marcyconstruction.com | Marcy Construction Company | 2246 Edgewood Avenue | | St. Louis Park | MN | 55426 | Electronic Service |
| Vezenia | Michael | mvezina@muellersales.com | Mueller Sales Corp. | 5104 Hillsboro Avenue North | | New Hope | MN | 55428 | Electronic Service |
| Braman | Barbara | barbarab@acomenvironmental.com | Acorn Environmental Consultants Inc. | 8040 Stevens Ave. S. | | Bloomington | MN | 55420 | Electronic Service |
| Bird | Josh | joshua.bird@ge.com | GE Energy | 2025 49th Ave N | | Minneapolis | MN | 55430 | Electronic Service |
| | | sindust1@msn.com | SII Inc | 7809 Southtown Center | Suite 109 | Bloomington | MN | 55431 | Electronic Service |
| Lee | John | jlee@barr.com | Barr Engineering Co. | 4700 W 77th St | Suite 200 | Minneapolis | MN | 55435 | Electronic Service |
| Segroves | Louise | lsegroves@barr.com | Barr Engineering | 4700 W. 77th St | | Minneapolis | MN | 55435 | Electronic Service |
| Pickar | Justin | justin@geronimowind.com | Geronimo Wind Energy | 7650 Edinborough Way | Suite 725 | Edina | MN | 55435 | Electronic Service |
| Healy | Chuck | chuckh@electrotech-inc.com | | 10600 Zinran Circle S | | Bloomington | MN | 55438 | Electronic Service |
| Dolan | Michael | mjdolan@dolanltd.com | | 6117 Scotia Drive | | Edina | MN | 55439 | Electronic Service |
| Vertes | Tom | hdrider4710@aol.com | | 4710 Orchid Lane North | | Plymouth | MN | 55446 | Electronic Service |
| Wood | John | wooder59@yahoo.com | | 4635 Minnesota Lane N | | Plymouth | MN | 55446 | Electronic Service |
| Mahan | Amy | aemahan@me.com | | 3810 Alvarado Lane North | | Plymouth | MN | 55446 | Electronic Service |
| Golzarian | Jafar | jafgol@gmail.com | | 17010 40th place north | | Plymouth | MN | 55446 | Electronic Service |
| Nickel | Jamie | jamie.s.nickel@comcast.net | | 3945 Alvarado LN N | | Plymouth | MN | 55446 | Electronic Service |
| Moeller | Keith | themoellers_2@hotmail.com | | 5150 Quantico Lane N | | Plymouth | MN | 55446 | Electronic Service |
| Anderson | David | danders542000@gmail.com | Saddlewood development resident | 3940 Alvarado lane North | | Plymouth | MN | 55446 | Electronic Service |
| lee | carol | cdlee1@comcast.net | | 14520 48th place north | | plymouth | MN | 55446 | Electronic Service |
| Efron | Daniel | danefron@yahoo.com | | 5200 Terraceview Lane N. | | Plymouth | MN | 55446 | Electronic Service |
| Stach | Paul | neyaz@q.com | | 18825 32nd Ave. N. | | Plymouth | MN | 55447 | Electronic Service |
| Shaw | Dennis | shawbad@msn.com | | 18930 33rd Ave No. | | Plymouth | MN | 55447 | Electronic Service |
| Eisenmann | Jon | jjeisenmann@comcast.net | | 3365 Olive Lane North | | Plymouth | MN | 55447 | Electronic Service |
| Mattson | Craig | cmattson@primetherapeutics.com | | 18690 34th Ave N | | Plymouth | MN | 55447 | Electronic Service |
| Rogers | Pam | pamroge@gmail.com | | 17995 31st Avenue North | | Plymouth | MN | 55447 | Electronic Service |
| Ciardelli | Ann | annciardelli@gmail.com | | 3135 Walnut Grove Lane N | | Plymouth | MN | 55447 | Electronic Service |
| Lehtis | Michele | mlehtis@hotmail.com | | 18725 27th Avenue N | | Plymouth | MN | 55447 | Electronic Service |
| Shaffer | David | david.shaffer@startribune.com | | 425 Portland Ave | | Mpls | MN | 55488 | Electronic Service |
| Crowe | Lilah | ichs@paulbunyan.net | Itasca County Historical Society | 201 N Pokegama Ave | | Grand Rapids | MN | 55744 | Electronic Service |
| Eskeli | Shanna | shaneske@hibbing.k12.mn.us | | 15112 N Little Sweden Rd | | Nashwauk | MN | 55769 | Electronic Service |
| Swafford | Tom | tswofford@umsi.us | UMS | 3947 East Calvary Road | | Duluth | MN | 55803 | Electronic Service |
| McVean | Brian | bmcvean@epcduluth.com | | 5203 Idlewild St | | Duluth | MN | 55804 | Electronic Service |
| Peterson | Kevin | kjp@ibew160.org | Local Union 160 | 846 48th Avenue NW | | Rochester | MN | 55901 | Electronic Service |
| Rohlfing | Dale and Suzanne | drohl24057@aol.com | | 2310 15th Ave NW | | Rochester | MN | 55901 | Electronic Service |
| Logan | James | james_9mm@yahoo.com | | 6384 Shetland Dr NW | | Rochester | MN | 55901 | Electronic Service |
| Kocer | Joseph | jmkoocer@myclearwave.net | | 5727 65th St. NW | | Rochester | MN | 55901 | Electronic Service |
| Bowman | M. | maebowman@aol.com | OMC | 210 9th St SE | | Rochester | MN | 55904 | Electronic Service |
| Katzung | Chad | chad@ibewlocal343.org | IBEW Local 343 | 9 80th steet S.E | | Rochester | MN | 55904 | Electronic Service |

| NameLast | NameFirst | Email | Organization | Address | Address2 | City | State | Zip | Delivery Method |
|----------------|------------------|---|--|---------------------------|--------------------|---------------|-------|-------|--------------------|
| Cook | Bill | wcook@rpu.org | Rochester Public Utilities | 4000 East River Road NE | | Rochester | MN | 55906 | Electronic Service |
| Hessenius | Vickie | vhessenius@myclearwave.net | | 69144 270th Street | | Dexter | MN | 55926 | Electronic Service |
| Malwitz | Jacob | jmalwitz@yahoo.com | | 10852 40 AVE NE | | Elgin | MN | 55932 | Electronic Service |
| Thoe | Susan | niftyfarm@myclearwave.net | | 26200 748 Street | | Hayfield | MN | 55940 | Electronic Service |
| Kispert | Lorry | lorrykzbag@hotmail.com | | 50669 20th Ave. | | Kenyon | MN | 55946 | Electronic Service |
| Greening | Mary | mary.greening@co.dodge.mn.us | Dodge County Environmental Services | 22 6 St E | Dept 123 | Mantorville | MN | 55955 | Electronic Service |
| Gau | Steve | sgau@sleepyeyetel.net | | 59178 411 Ave | | Mazeppa | MN | 55956 | Electronic Service |
| Scheffler | Lowell | lvscheffler@hotmail.com | | 49862 240th Ave Way | | Mazeppa | MN | 55956 | Electronic Service |
| Kennedy | Beau | beaukennedy@yahoo.com | | 59525 415th Ave. | | Mazeppa | MN | 55956 | Electronic Service |
| Baertlein | Cheryl | baertlein.cheryl@mayo.edu | | 56901 County Road 21 | | Mazeppa | MN | 55956 | Electronic Service |
| Lyke | Richard | rtyke@pitel.net | Oronoco Township | P.O. Box 89 | 13051 18th Ave. NW | Oronoco | MN | 55960 | Electronic Service |
| Muller | Sharon | muller.sharon@mayo.edu | | 3078 125th St. NW | | Oronoco | MN | 55960 | Electronic Service |
| Davidson | Matt | mdavidson@isd2899.k12.mn.us | ISD 2899 | 500 W Broadway Ave | | Plainview | MN | 55964 | Electronic Service |
| Morse | Joseph | josephmorse@hotmail.com | Bluff Land Environmental Watch | PO Box 331 | | Winona | MN | 55987 | Electronic Service |
| Norman | C. Merl Anna Mae | NA | Laymen for Christ Woodland Camp | 39757 573rd Street | 39814 573rd Street | Zumbro Falls | MN | 55991 | Paper Service |
| Schumacher | Rod | rschumacher@is-ea.com | I S Group | 115 E. Hickory St. 300 | | Mankato | MN | 56001 | Electronic Service |
| Howden | Rick | rick.howden@mail.house.gov | Congressman Tim Walz | 227 E Main Street | Suite 220 | Mankato | MN | 56001 | Electronic Service |
| Schmidt | Kris | kristines@mvec.net | Blakeley Township | 17501 West 250th Street | | Belle Plaine | MN | 56011 | Electronic Service |
| Frisk-Thompson | Lori | lorift@utplus.com | CMMPA | 459 S Grove Street | | Blue Earth | MN | 56013 | Electronic Service |
| Stindtman | Michele | michele.stindtman@co.faribault.mn.us | Planning Zoning Administrator | 415 S. Grove Street | | Blue Earth | MN | 56013 | Electronic Service |
| Mittelstaedt | Steven | mctopdetailers@hotmail.com | | 32097 Sanborn DR | | montgomery | MN | 56069 | Electronic Service |
| Hofman | Joe and Arlene | jahfmm@bevcomm.net | | 2521 260th Street West | | New Prague | MN | 56071 | Electronic Service |
| Entinger | Paul | bobbie97@bevcomm.net | | 13821 300th St. | | New Prague | MN | 56071 | Electronic Service |
| Schaefer | Benjamin | benjamin.schaefer@dnr.state.mn.us | Minnesota Department of Natural Resources | 261 Highway 15 South | | New Ulm | MN | 56073 | Electronic Service |
| Mixon | Kevin | kevin.mixon@dnr.state.mn.us | DNR | 261 HWY 15 South | | New Ulm | MN | 56073 | Electronic Service |
| Haseleu | Randy and Rose | | | 420 South Hoyt | | Springfield | MN | 56087 | Paper Service |
| Simmons | Jerrold | jc7simmons@mvtwireless.com | Simmons Farms | 83070 600th Avenue | | Alpha | MN | 56111 | Electronic Service |
| Withers | Sarah | slwithers@nfpinc.com | | 74576 560th Ave. | | Jackson | MN | 56143 | Electronic Service |
| Bromeland | Jennifer | jbromeland@cityofjacksonmn.com | City of Jackson | 80 West Ashley Street | | Jackson | MN | 56143 | Electronic Service |
| Swenson | Steven | sswenson@pipestonestar.com | Pipestone Publishing | 115 2nd St. NE | | Pipestone | MN | 56164 | Electronic Service |
| Davis | Thomas | NA | | 1161 50th Ave | | Sherburn | MN | 56171 | Paper Service |
| Bair | Annette | phydev@swrdc.org | SRDC - SW CERT | 2401 Broadway Ave | | Slayton | MN | 56172 | Electronic Service |
| Potts | Larry | slpotts@frontier.com | | 1643 100th Ave | | Welcome | MN | 56181 | Electronic Service |
| Brockman | Darin | dbrockman@awtxglobal.com | | 1313 110th ave | | Welcome | MN | 56181 | Electronic Service |
| Bouta | Michelle | michelle.bouta@umvrdc.org | Upper Minnesota Valley Regional Development Commission | 323 West Schleiman Avenue | | Appleton | MN | 56208 | Electronic Service |
| Rebman | Larry | larryemls@hotmail.com | SGB Wind Transformers | P.O. Box 122 | | Appleton | MN | 56208 | Electronic Service |
| Stoks | Joe | amsjoe350@yahoo.com | | 1926 160th Ave | | Canby | MN | 56220 | Electronic Service |
| Plagge | David | dplagge@fageneng.com | Fagen Engineering LLC | 501 W. Hwy 212 | PO Box 159 | Granite Falls | MN | 56241 | Electronic Service |
| Stengel | Al | pat_stengel@hotmail.com | | 2244 520 Street | | Hanley Falls | MN | 56245 | Electronic Service |
| Drusch | Dean | ddrusch@redred.com | | 44465 260th Street | | Morgan | MN | 56266 | Electronic Service |
| Schroeder | Randy | rschroeder@frandsenbank.com | | 33763 327th Ave. | | Morgan | MN | 56266 | Electronic Service |
| Vetsch | Jeff | jeffvetsch@cleanenergyresourceteams.org | CERTs | 112 Norwood St. | | New London | MN | 56273 | Electronic Service |
| Rath | Julie | julie@redwoodfalls.org | MN Valley Regional Rail Authority | PO Box 481 | 200 S Mill Street | Redwood Falls | MN | 56283 | Electronic Service |
| Bellig | Peter | jokremin@mchsi.com | | 207 Cedar Cliff Road | | Redwood Falls | MN | 56283 | Electronic Service |
| Krekelberg | Trudi | celtichand56@yahoo.com | | 820 Hamlet Dr S | | Avon | MN | 56301 | Electronic Service |
| Kenning | Darren | darrenk@kenningoutsource.com | | 7242 Old Hwy 52 | | St. Cloud | MN | 56303 | Electronic Service |
| Fassett | Jeff | fassettj@iemenergy.com | IEM Energy Consultants Inc. | 5200 Birchwood Ct NW | | Alexandria | MN | 56308 | Electronic Service |
| Schwalbe | Steve and Lisa | stevetisa9@aol.com | | 16825 363rd St | | Avon | MN | 56310 | Electronic Service |
| Opatz | Roger | bmo2504@juno.com | | 37579 County Road 155 | | Avon | MN | 56310 | Electronic Service |
| Jewell | Sarah | sjewell02@hamlineuniversity.edu | | 33294 112th Avenue | | Avon | MN | 56310 | Electronic Service |
| Notch | Steve | snotch@albanytel.com | Millwood Township | 28086 38th Street | | Freeport | MN | 56331 | Electronic Service |
| Mueller | Colleen | cmueller@wildblue.net | | 22186 State Hwy 4 | | Paynesville | MN | 56362 | Electronic Service |
| Voller | James | jvoller@clearwire.net | | 33038 102nd Ave | | St. Joseph | MN | 56374 | Electronic Service |
| Kuebelbeck | James | jckueb@clearwire.net | | 28391 Kelp Rd | | St. Joseph | MN | 56374 | Electronic Service |

| NameLast | NameFirst | Email | Organization | Address | Address2 | City | State | Zip | Delivery Method |
|-----------------------|-------------------|--------------------------------|---|-------------------------|-------------------|-------------------|-------|------------|--------------------|
| Legatt | Lois and Dennis | llegatt@yahoo.com | | 10960 385th Street | | St. Joseph | MN | 56374 | Electronic Service |
| Gohmann | Curt and Mary Pat | candmpg@cloudnet.com | | 35123 County Road 2 | | St. Joseph | MN | 56374 | Electronic Service |
| Rothaus | Richard | rothaus@trefoilcultural.com | Trefoil Cultural and Environmental Heritage | 1965 W. Highview Dr | | Sauk Rapids | MN | 56379 | Electronic Service |
| Slukich | Tom | tom@nationalconductor.com | National Conductor Constructors | 18119 Hwy 371 North | | Brainerd | MN | 56401 | Electronic Service |
| Rubink | Annette | annetter@nationalconductor.com | National Conductor | 18119 State Highway 371 | | Brainerd | MN | 56401 | Electronic Service |
| Hurley | Wayne | wayne@wcf.org | West Central Initiative | 1000 Western Ave. | PO Box 318 | Fergus Falls | MN | 56538-0318 | Electronic Service |
| Stradley | Kathleen and Scot | katstradley@gmail.com | | 3116 Highway 9 South | | Glyndon | MN | 56547 | Electronic Service |
| Herzog | Natalie | naherzog@msn.com | | 10050 57th Avenue N | | Glyndon | MN | 56547 | Electronic Service |
| Morse | Todd | toddmorse@cableone.net | Trinity Investments LLC | 3416 Village Green Dr | | Moorhead | MN | 56560 | Electronic Service |
| Jovonovich-Lesmeister | Jacqui | jacquijovonovich@gmail.com | Lesmeister Flying Service | 8468 140th Ave S | | Sabin | MN | 56580 | Electronic Service |
| Wright-Knutson | Jan | jrwright@bemidji.k12.mn.us | | 5111 Lavinia Road NE | | Bemidji | MN | 56601 | Electronic Service |
| Crane | John | johncrane@fishing@gmail.com | | 1250 Wee Gwaus Dr SW | | Bemidji | MN | 56601 | Electronic Service |
| Stoller | William | w.stoller@yahoo.com | | 21477 490th St. | | Clearbrook | MN | 56634-4012 | Electronic Service |
| Gebhardt | K. A. | kageb1@gvtel.com | | 43901 253rd Avenue | | Leonard | MN | 56652 | Electronic Service |
| Hulst | Rhett | rhulst@farmcredit.com | | 50291 Cty Rd 12 | | Salol | MN | 56756 | Electronic Service |
| Melvie | Kraig | dmelvie@wiktel.com | K K Trucking Inc. | 21738 165th ave nw | | viking | MN | 56760 | Electronic Service |
| Nelson | Kevin | keevinkellyn@swiftel.net | Utility Shareholders of South Dakota | 120 3rd. Ave. S | | Brookings | SD | 57006 | Electronic Service |
| Swartz | Sean | sswartz@braunintertec.com | | 526 10th Street NE | P.O. Box 485 | West Fargo | ND | 58078 | Electronic Service |
| DeLong | Skip | skdelong@polarcomm.com | Wind Energy Services | 15317 11th Street N.E. | | Mayville | ND | 58257 | Electronic Service |
| Schulz | Amy | amy@duraflexinc.com | Duraflex Inc. | 765 Industrial Dr | | Cary | IL | 60013 | Electronic Service |
| Dunkle | Ledy | NA | Aldridge Electric Inc. | 844 East Rockland Road | | Libertyville | IL | 60048 | Paper Service |
| Fehr | Timothy | timothy_fehr@transcanada.com | TransCanada | 827 N. Liberty Street | | Morris | IL | 60450 | Electronic Service |
| Trivellizzi | Marco | marco.trivellizzi@kiewit.com | Mass. Electric Coonstruction Company | 8501 W. Higgins | Suite 400 | Chicago | IL | 60631 | Electronic Service |
| Kennon | Peter | pkennon@acciona-na.com | Acciona Energy N.A. Corp | 333 W Wacker Dr | Suite 1500 | Chicago | IL | 60657 | Electronic Service |
| Butner | Joe | jbutner@stresscrete3.com | The StressCrete Group | 14503 Wallick Rd. | | Atchison | KS | 66002 | Electronic Service |
| Guajardo | Floyd | floydg@pennwell.com | PennWell Corporation | 1455 West Loop South | Suite 400 | Houston | TX | 77027 | Electronic Service |
| Clark | Marie | mir-mir-z@suddenlink.net | | 2901 28th Street | | Snyder | TX | 79549 | Electronic Service |
| Galloway | Chad | chad.galloway@arionenergy.com | Arion Energy LLC. | 8400 E. Crescent Pkwy | Suite 600 | Greenwood Village | CO | 80111 | Electronic Service |
| Behrens | Enid | enidbehrens@q.com | | 2971 W 119th Ave 103 | | Westminster | CO | 80234 | Electronic Service |
| Ulmer | Emily | emily.ulmer@sierraclub.org | Sierra Club | 85 Second Street | 2nd floor | San Francisco | CA | 94105 | Electronic Service |
| Davis | Hadley | hadley.davis@sierraclub.org | Sierra Club | 85 Second St. | | San Francisco | CA | 94105 | Electronic Service |
| Schultz | Jon | jashultz@excite.com | | 7846 Donegal Cove | 7846 Donegal Cove | Eden Prairie | MN | | Electronic Service |
| Washburn | Nicole | nwashburn@hotmail.com | | 601 Creek Road | | Chaska | MN | | Electronic Service |
| Carlson | Hali | halicarlson@kmts.ca | NCC | 89 Norman Drive | | Kenora Ontario | | P9N 3T6 | Electronic Service |

Appendix B

Project Detail Mapbook

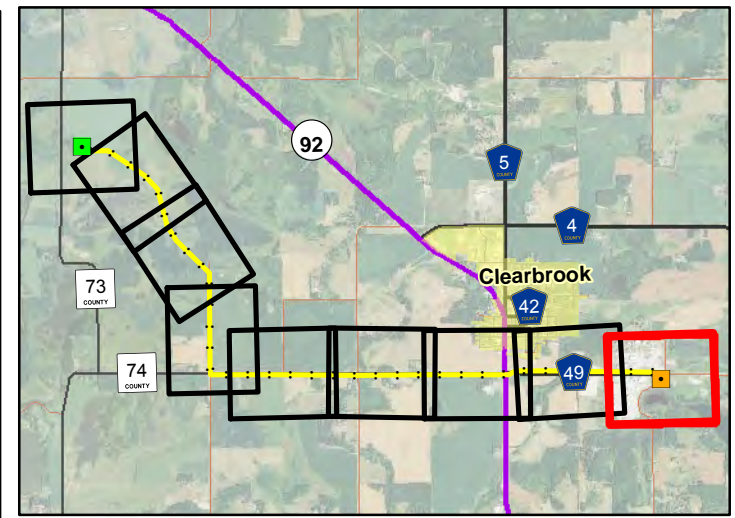
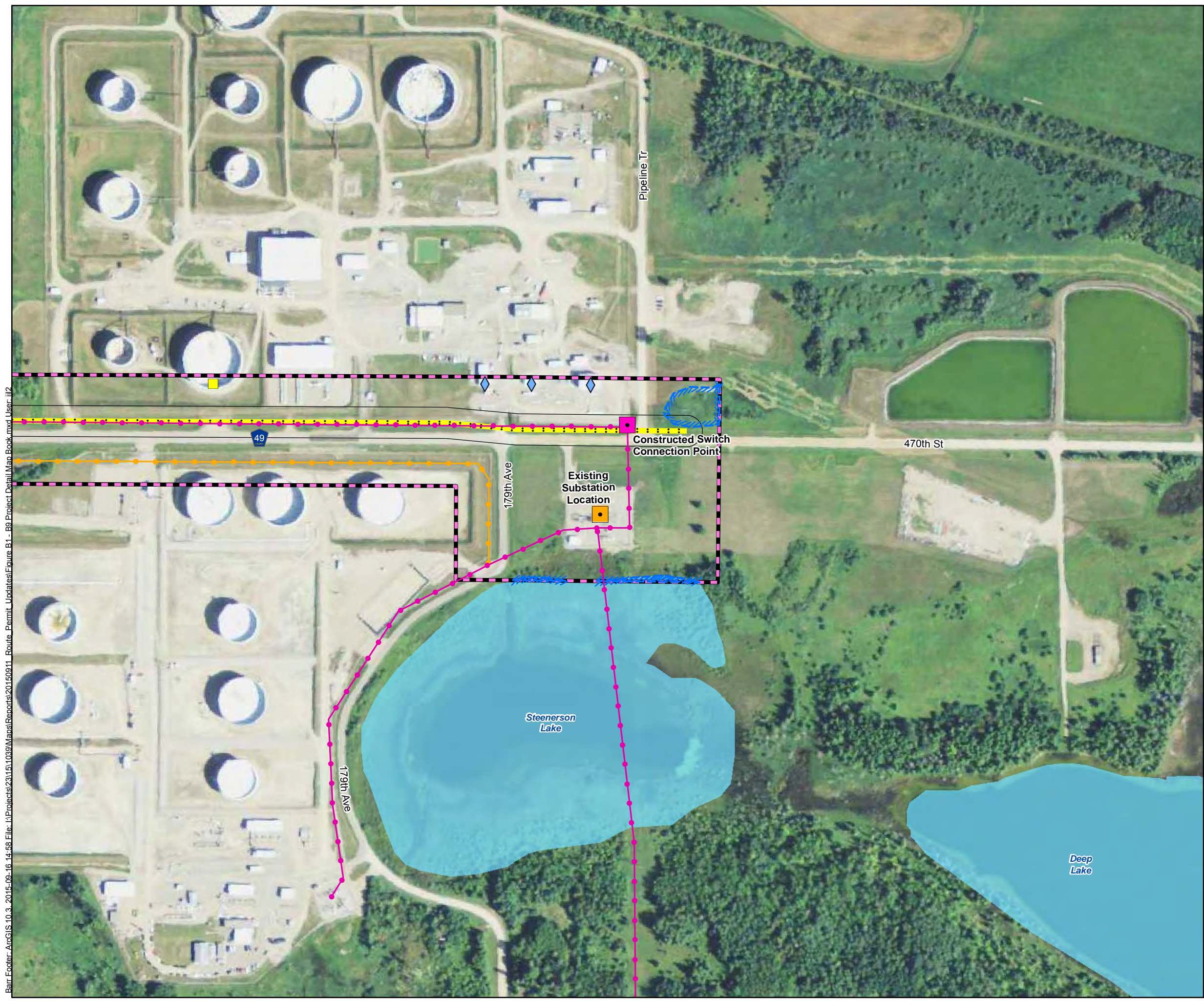

- Constructed Switch Connection Point
 - Existing Substation Location
 - Clearbrook West Substation Footprint
- Buildings by Type**
- ◆ Non-Residential
 - Silo
 - Tank
- Existing Distribution and Transmission Lines**
- Anticipated Alignment
 - Low Voltage Distribution
 - 115 kV
 - PWI Watercourse
 - PWI Basin
 - NWI Wetland
 - Anticipated 100ft ROW
 - Anticipated Route Width

Image Source: 2013 Farm Service Agency

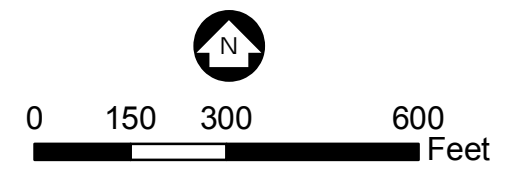
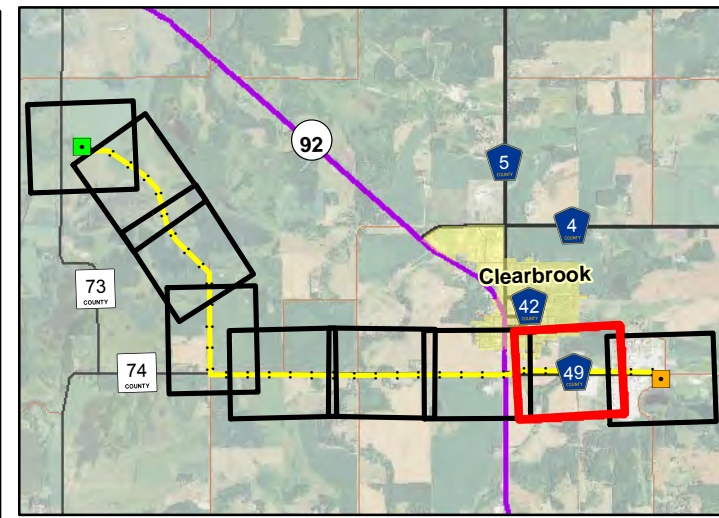
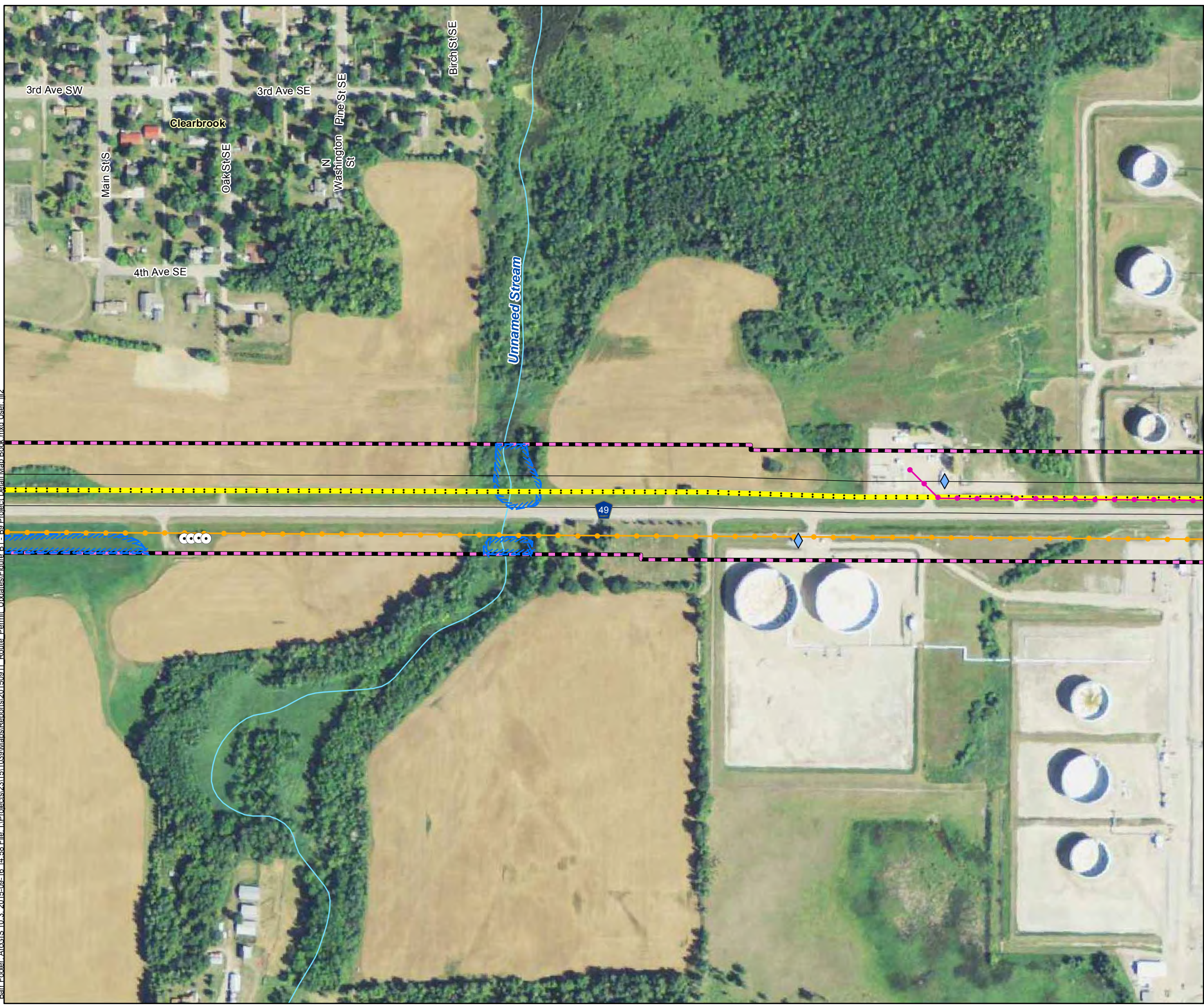

Figure B-1

Map 1 of 9
 PROJECT DETAIL MAP BOOK
 Proposed Clearbrook – Clearbrook West
 115 kV HVTL Project
 Minnkota Power
 Clearwater County, MN

Barr Footer: ArcGIS 10.3, 2015-09-16 14:58 File: I:\Projects\23115\10391\Map\Reports\20150911_Route_Permit_Update\Figure_B1 - B9 Project Detail Map Book.mxd User: jll2

Barr Footer: ArcGIS 10.3 - 2015-09-16 14:58 File: I:\Projects\23115\10391\Map\Reports\20150911_Route_Permit_Updates\Figure B-1 - B9 Project Detail Map Book.mxd User: jll2



- Constructed Switch Connection Point
- Existing Substation Location
- Clearbrook West Substation Footprint
- Buildings by Type**
- ◆ Non-Residential
- Silo
- Tank
- - - Anticipated Alignment
- Existing Distribution and Transmission Lines**
- - - Low Voltage Distribution
- - - 115 kV
- ~ PWI Watercourse
- PWI Basin
- NWI Wetland
- Anticipated 100ft ROW
- Anticipated Route Width

Image Source: 2013 Farm Service Agency

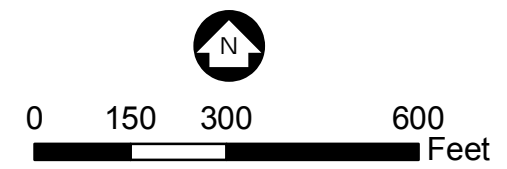
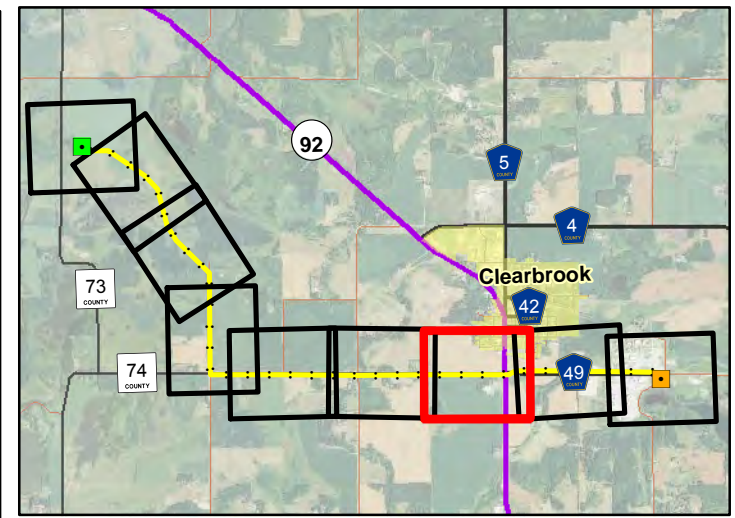
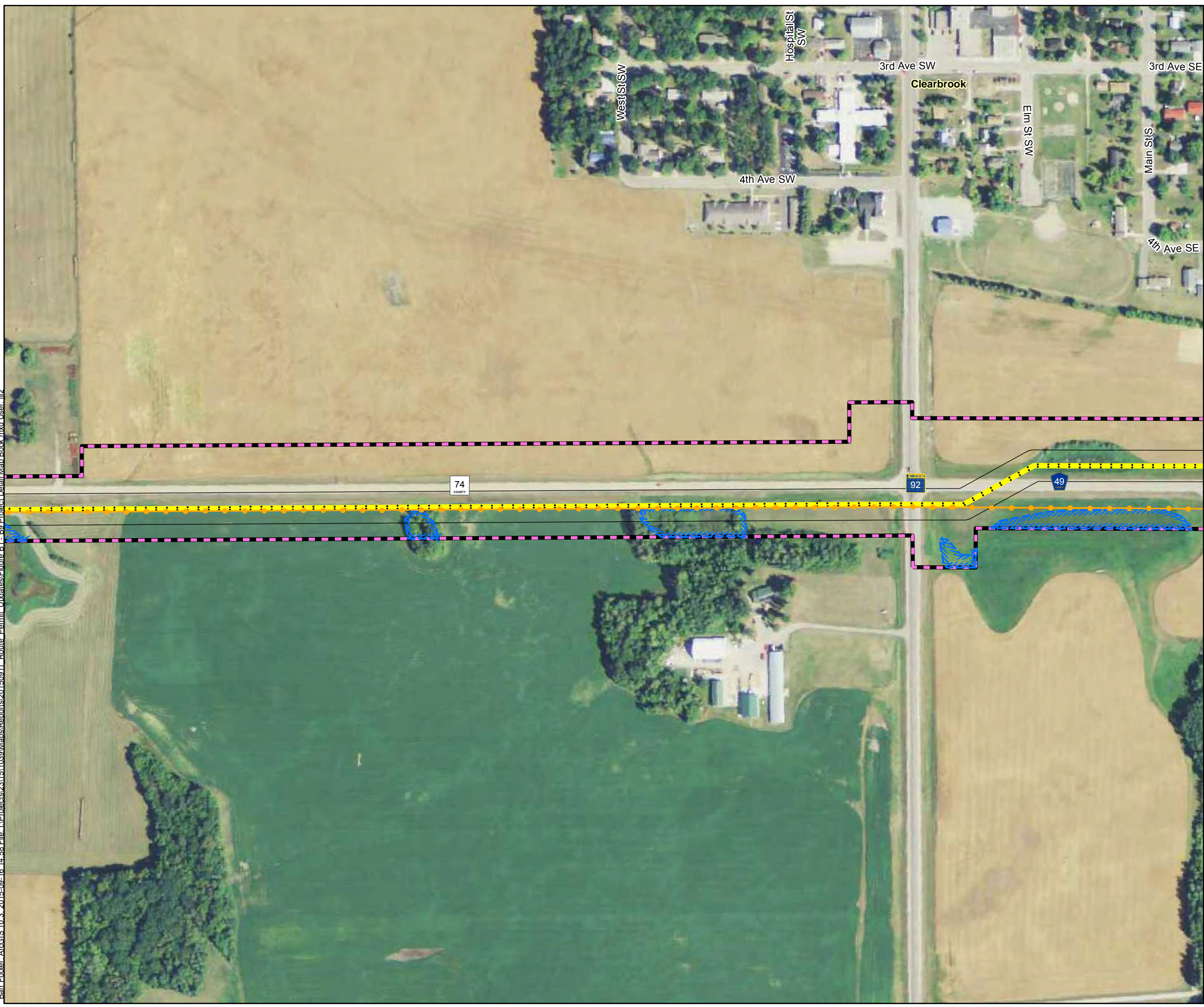

Figure B-2

Map 2 of 9
 PROJECT DETAIL MAP BOOK
 Proposed Clearbrook – Clearbrook West
 115 kV HVTL Project
 Minnkota Power
 Clearwater County, MN

Barr Footer: ArcGIS 10.3 - 2015-09-16 14:58 File: I:\Projects\23115\10391\Map\Reports\20150911_Route_Permit_Updates\Figure B-1 - B9 Project Detail Map Book.mxd User: jll2



- Constructed Switch Connection Point
- Existing Substation Location
- ▬ Clearbrook West Substation Footprint
- Buildings by Type**
- ◆ Non-Residential
- Silo
- Tank
- ▬ Anticipated Alignment
- Existing Distribution and Transmission Lines**
- ▬ Low Voltage Distribution
- ▬ 115 kV
- ▬ PWI Watercourse
- PWI Basin
- ▬ NWI Wetland
- Anticipated 100ft ROW
- Anticipated Route Width

Image Source: 2013 Farm Service Agency

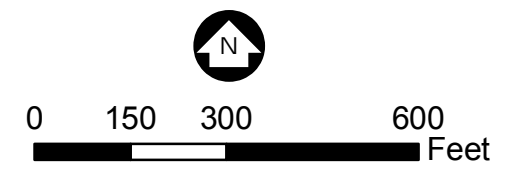
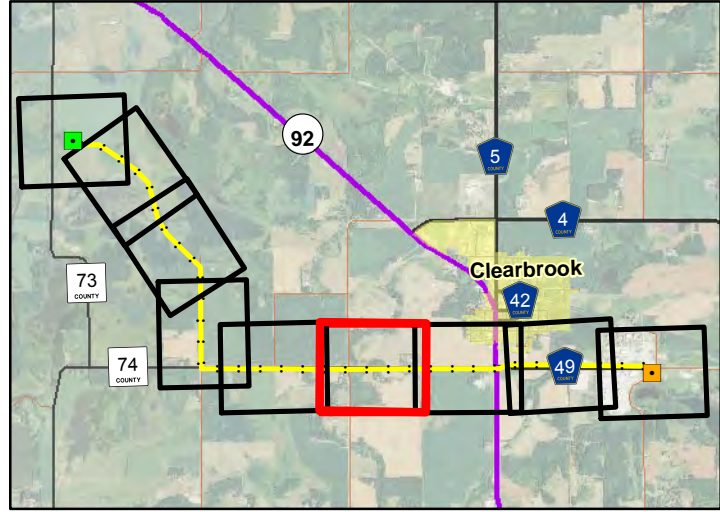
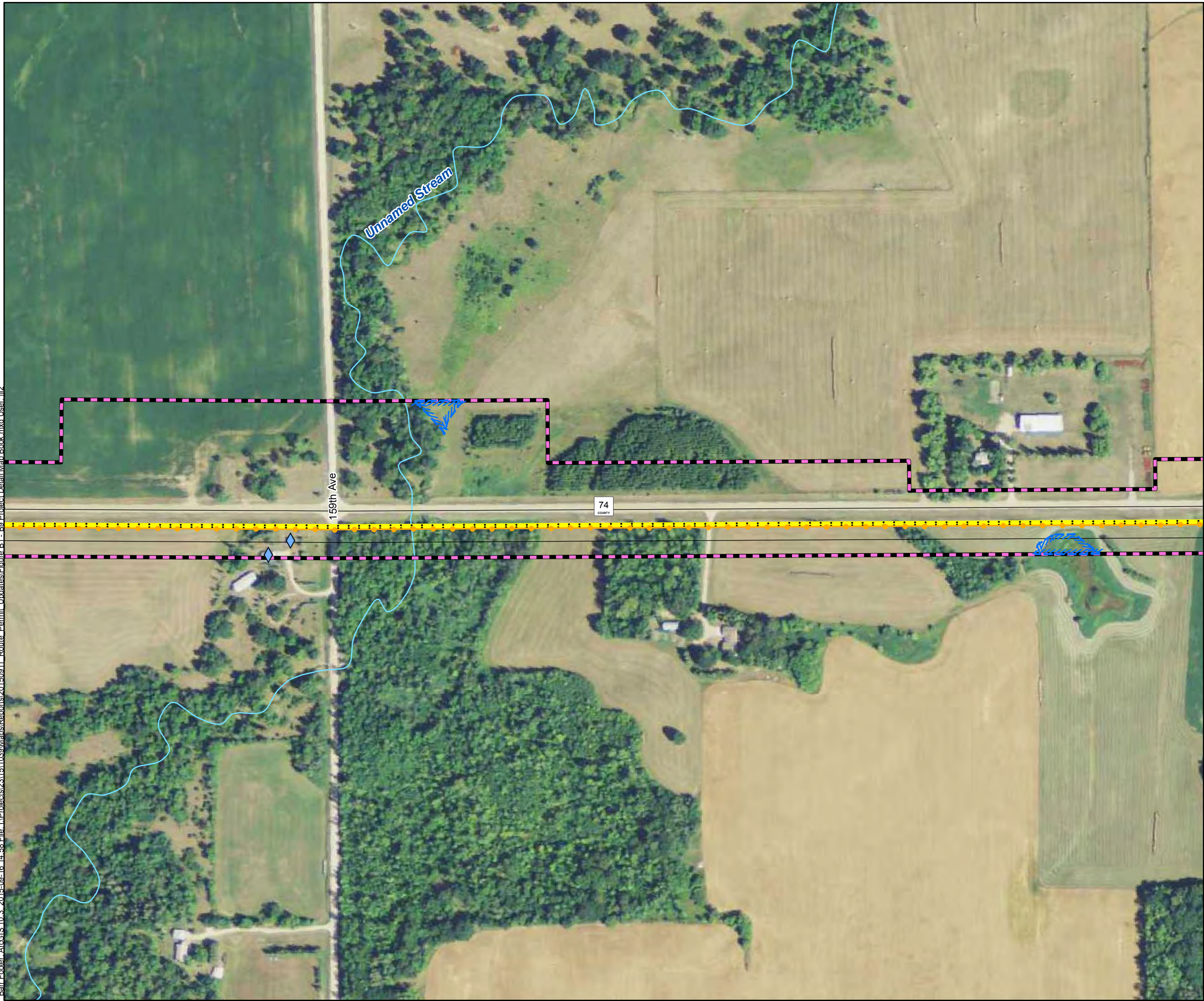

Figure B-3

Map 3 of 9
PROJECT DETAIL MAP BOOK
Proposed Clearbrook – Clearbrook West
115 kV HVTL Project
Minnkota Power
Clearwater County, MN

Barr Footer: ArcGIS 10.3 - 2015-09-16 14:58 File: I:\Projects\2311510391\Map\Recon\20150911_Route_Permit_Update\Figure B1 - B9 Project Detail Map Book.mxd User: jll2



- Constructed Switch Connection Point
- Existing Substation Location
- Clearbrook West Substation Footprint
- Buildings by Type**
- ◆ Non-Residential
- Silo
- Tank
- ▨ Anticipated Alignment
- Existing Distribution and Transmission Lines**
- Low Voltage Distribution
- 115 kV
- PWI Watercourse
- PWI Basin
- NWI Wetland
- Anticipated 100ft ROW
- Anticipated Route Width

Image Source: 2013 Farm Service Agency

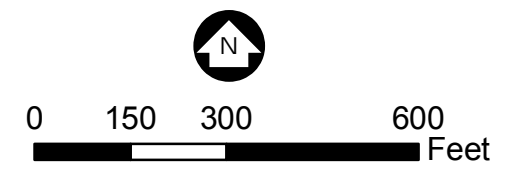
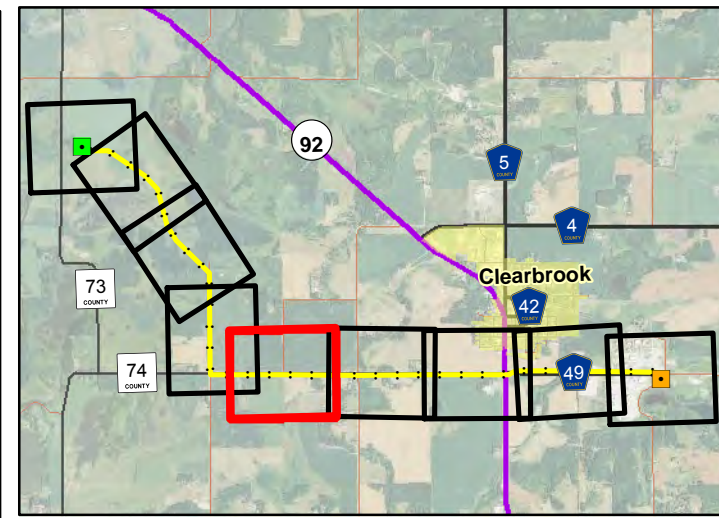
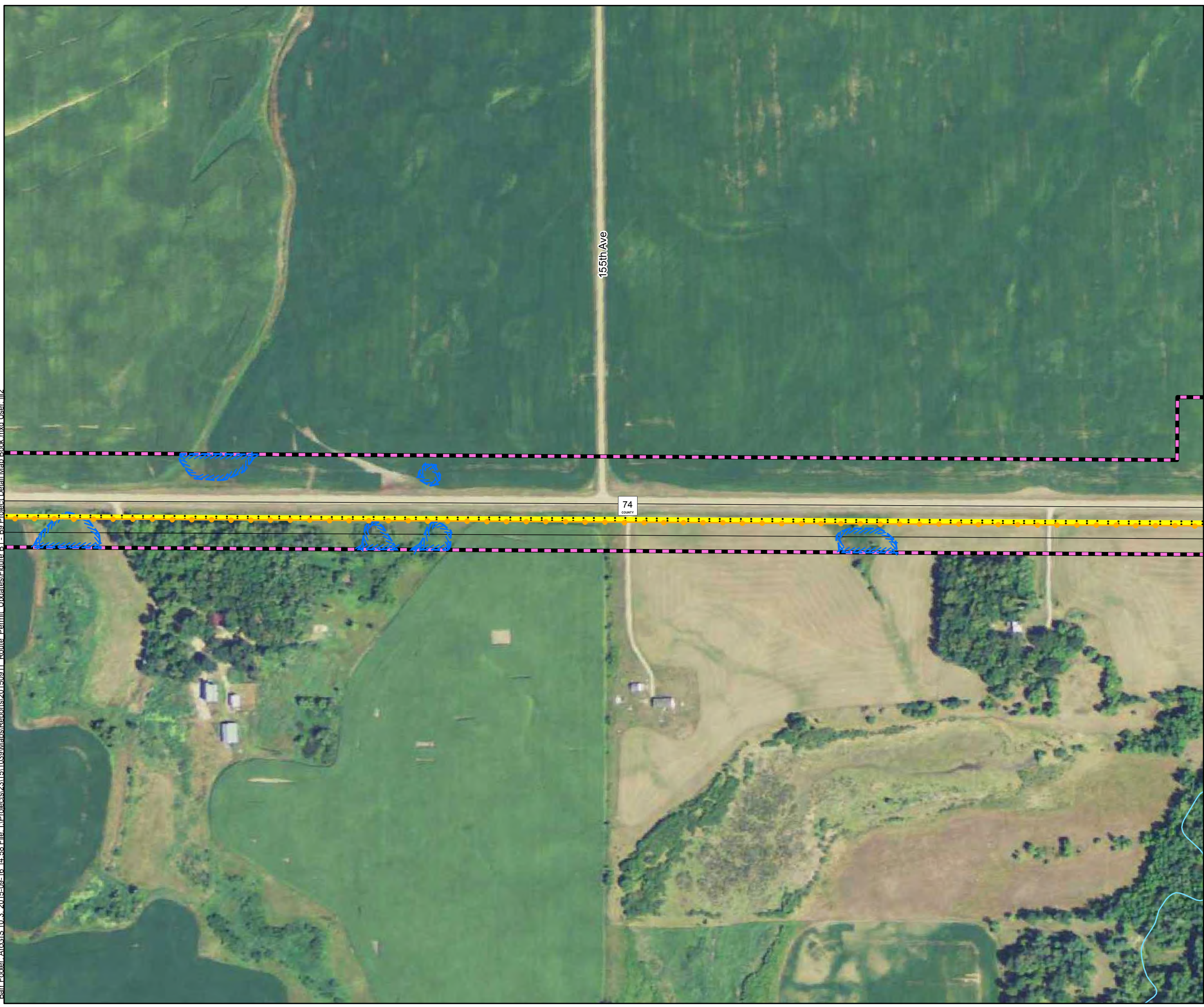

Figure B-4

Map 4 of 9
PROJECT DETAIL MAP BOOK
Proposed Clearbrook – Clearbrook West
115 kV HVTL Project
Minnkota Power
Clearwater County, MN

Barr Footer: ArcGIS 10.3 - 2015-09-16 14:58 File: I:\Projects\23115\10391\Map\Renovs\20150911_Route_Permit_Updates\Figure B-1 - B9 Project Detail Map Book.mxd User: jll2



- Constructed Switch Connection Point
 - Existing Substation Location
 - Clearbrook West Substation Footprint
- Buildings by Type**
- ◆ Non-Residential
 - Silo
 - Tank
- Existing Distribution and Transmission Lines**
- Low Voltage Distribution
 - 115 kV
 - PWI Watercourse
 - PWI Basin
 - NWI Wetland
 - Anticipated 100ft ROW
 - Anticipated Route Width

Image Source: 2013 Farm Service Agency

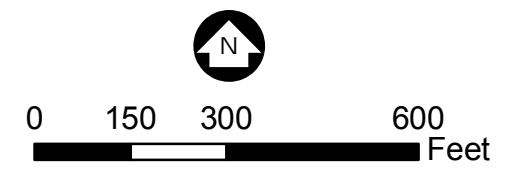
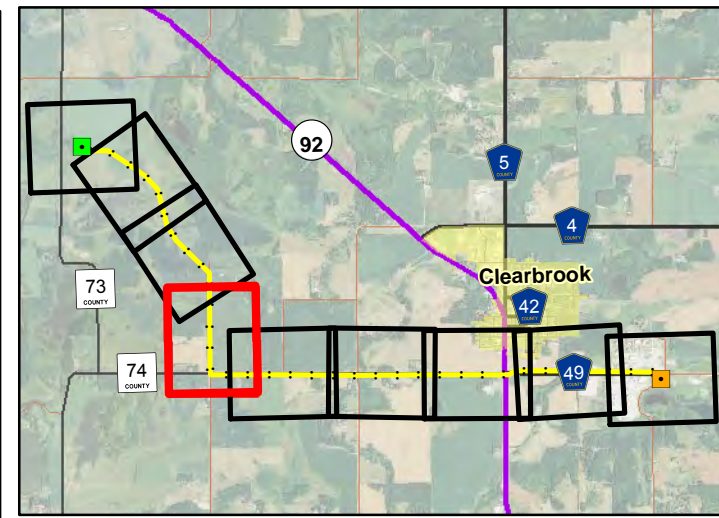
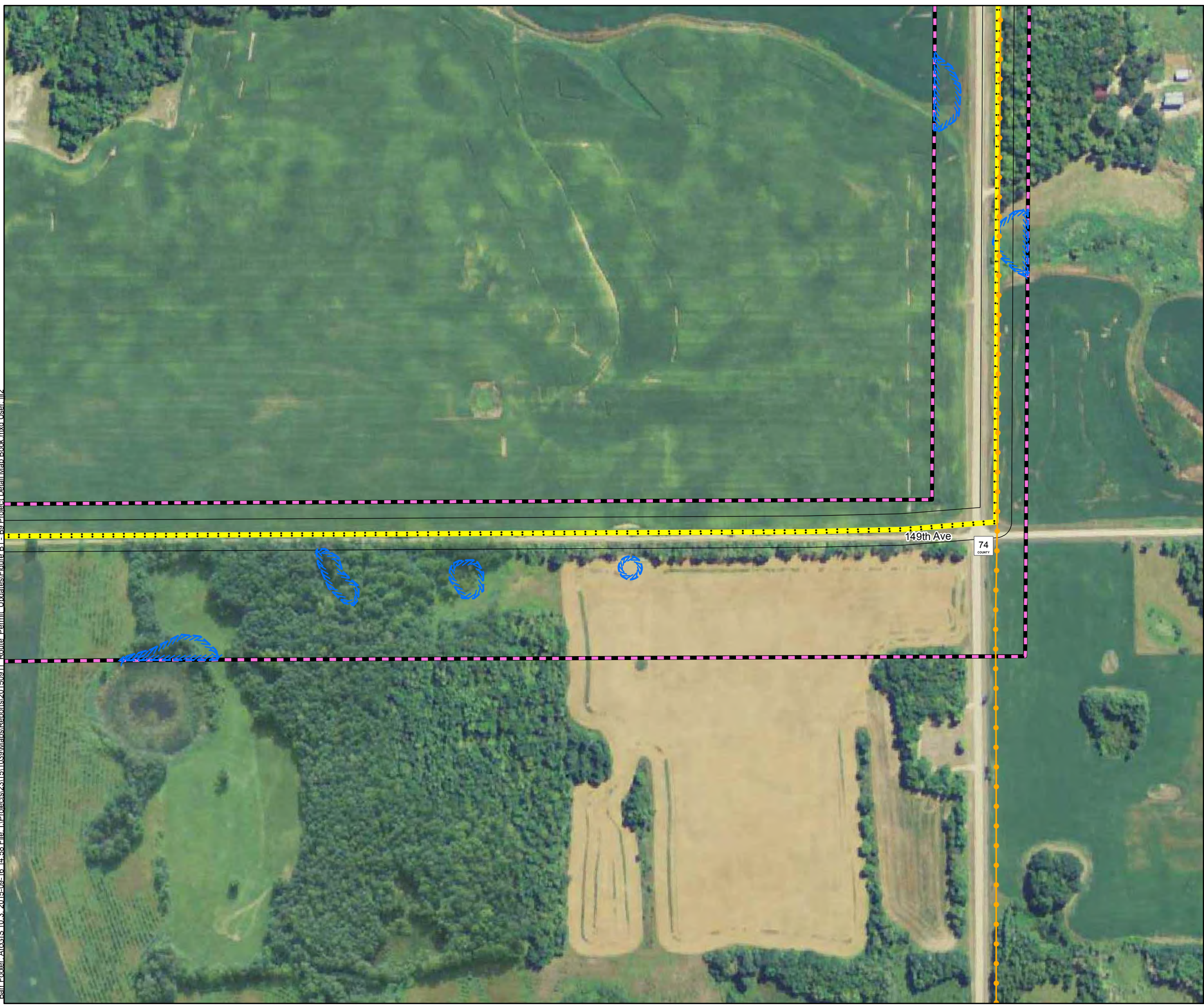

Figure B-5

Map 5 of 9
 PROJECT DETAIL MAP BOOK
 Proposed Clearbrook – Clearbrook West
 115 kV HVTL Project
 Minnkota Power
 Clearwater County, MN

Barr Footer: ArcGIS 10.3, 2015-09-16 14:58 File: I:\Projects\23115\10391\Map\Renovs\20150911 Route_Permit_Updates\Figure B-1 - B9 Project Detail Map Book.mxd User: jll2



- Constructed Switch Connection Point
- Existing Substation Location
- Clearbrook West Substation Footprint
- Buildings by Type**
- ◆ Non-Residential
- Silo
- Tank
- ▨ Anticipated Alignment
- Existing Distribution and Transmission Lines**
- Low Voltage Distribution
- 115 kV
- ~ PWI Watercourse
- PWI Basin
- ▨ NWI Wetland
- Anticipated 100ft ROW
- Anticipated Route Width

Image Source: 2013 Farm Service Agency

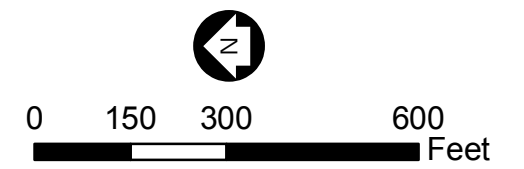

Figure B-6

Map 6 of 9

PROJECT DETAIL MAP BOOK

Proposed Clearbrook – Clearbrook West

115 kV HVTL Project

Minnkota Power

Clearwater County, MN

Barr Footer: ArcGIS 10.3 - 2015-09-16 14:58 File: I:\Projects\2315\1039\Map\Map Book.mxd User: jll2

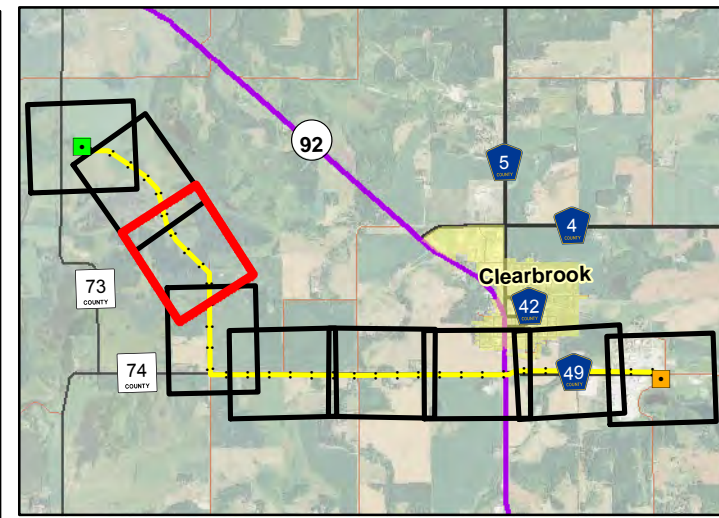
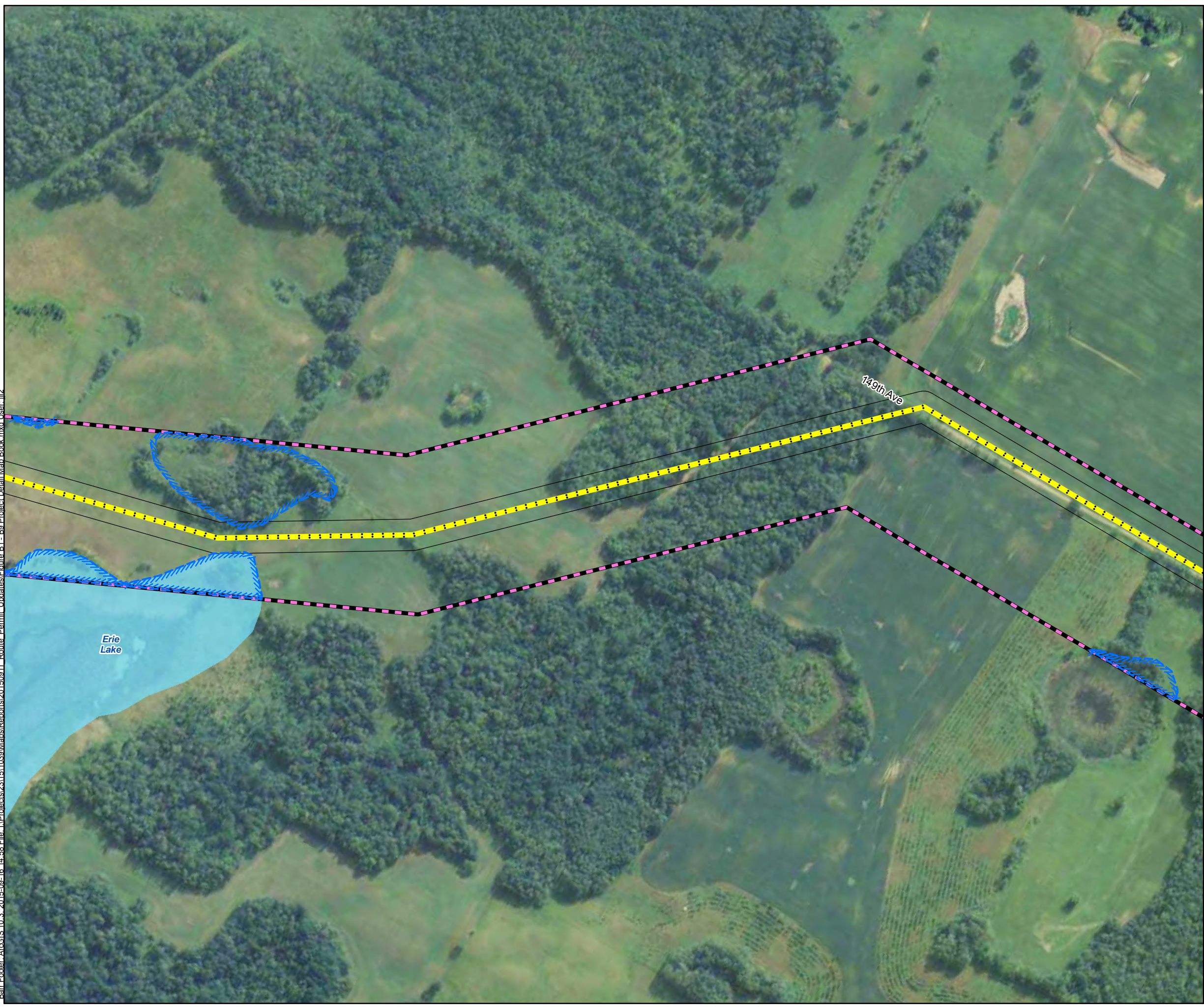

- Constructed Switch Connection Point
- Existing Substation Location
- Clearbrook West Substation Footprint
- Buildings by Type**
 - Non-Residential
 - Silo
 - Tank
- Anticipated Alignment
- Existing Distribution and Transmission Lines**
 - Low Voltage Distribution
 - 115 kV
- PWI Watercourse
- PWI Basin
- NWI Wetland
- Anticipated 100ft ROW
- Anticipated Route Width

Image Source: 2013 Farm Service Agency



Figure B-7

Map 7 of 9
 PROJECT DETAIL MAP BOOK
 Proposed Clearbrook – Clearbrook West
 115 kV HVTL Project
 Minnkota Power
 Clearwater County, MN

Barr Footer: ArcGIS 10.3.2015-09-16 14:58 File: I:\Projects\23115\10391\Map\Book\Book.mxd User: jll2

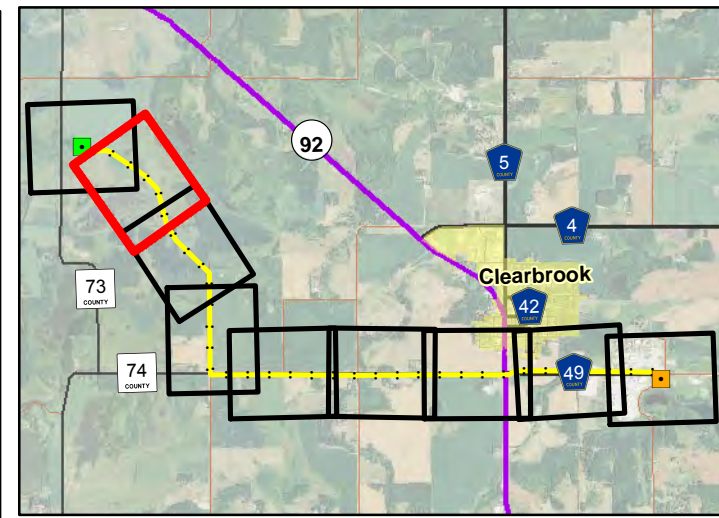
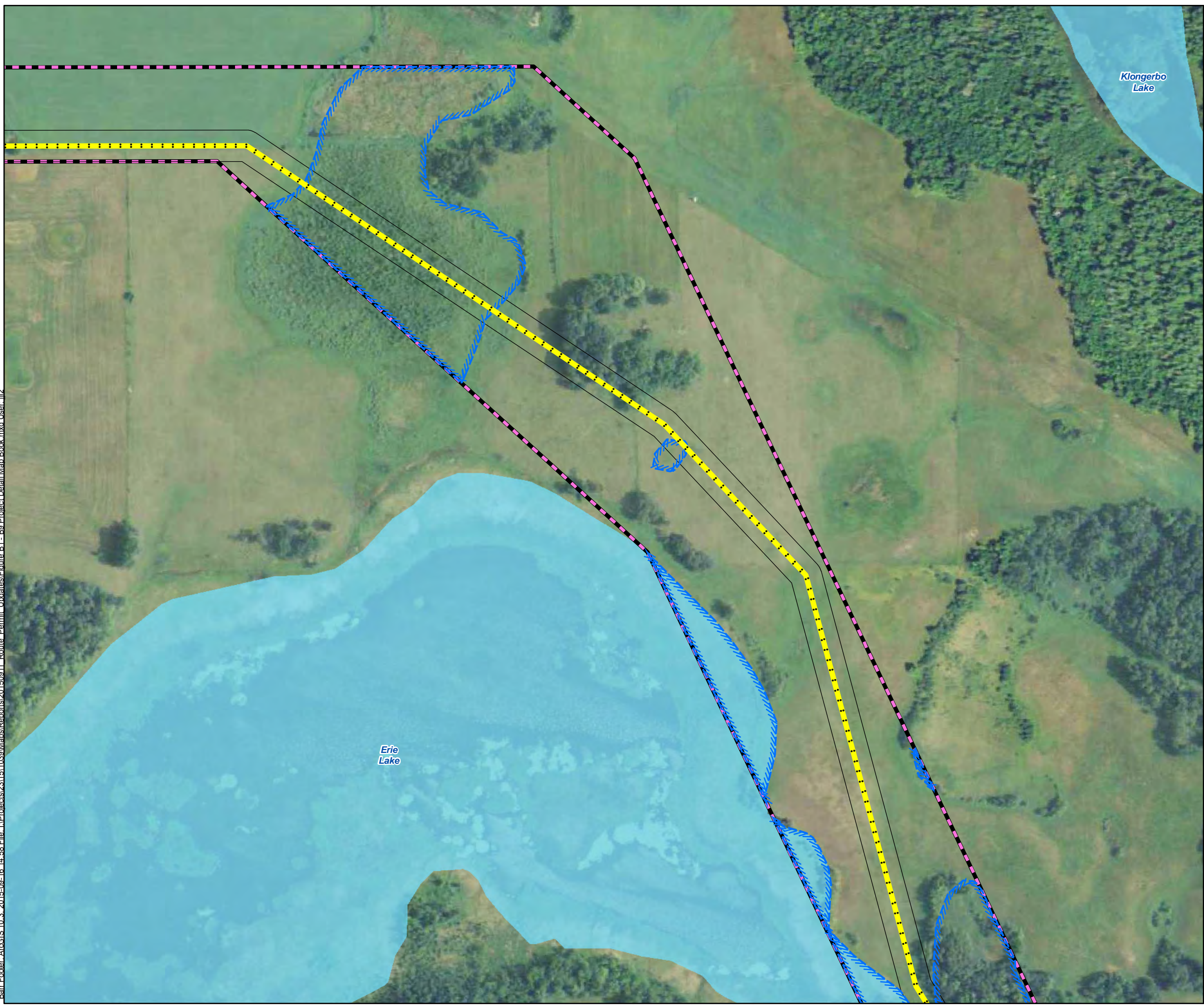

- Constructed Switch Connection Point
- Existing Substation Location
- Clearbrook West Substation Footprint
- Buildings by Type**
 - Non-Residential
 - Silo
 - Tank
- Anticipated Alignment
- Existing Distribution and Transmission Lines**
 - Low Voltage Distribution
 - 115 kV
 - PWI Watercourse
 - PWI Basin
 - NWI Wetland
 - Anticipated 100ft ROW
 - Anticipated Route Width

Image Source: 2013 Farm Service Agency

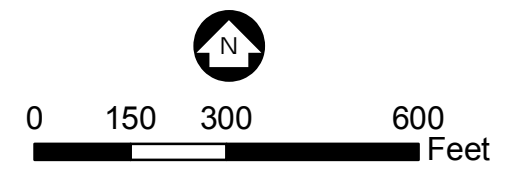

Figure B-8

Map 8 of 9

PROJECT DETAIL MAP BOOK

Proposed Clearbrook – Clearbrook West

115 kV HVTL Project

Minnkota Power

Clearwater County, MN

Barr Footer: ArcGIS 10.3, 2015-09-16 14:58 File: I:\Projects\2315\10391\Map\Reports\20150911_Route_Permit_Updates\Figure_B1_B9 Project Detail Map Book.mxd User: jll2

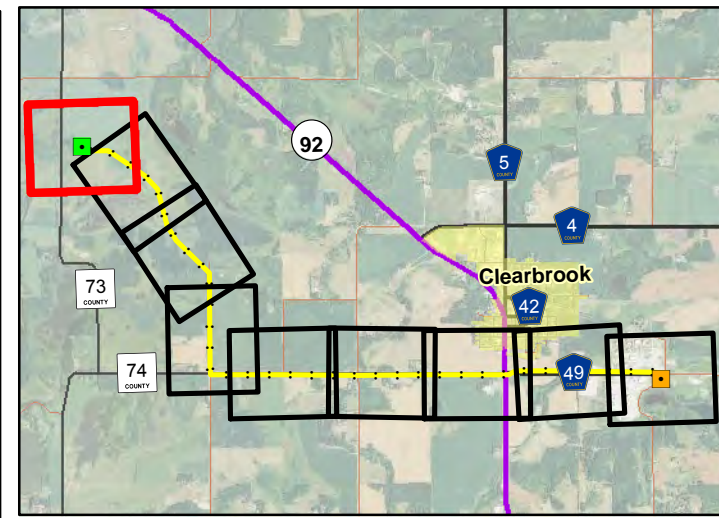
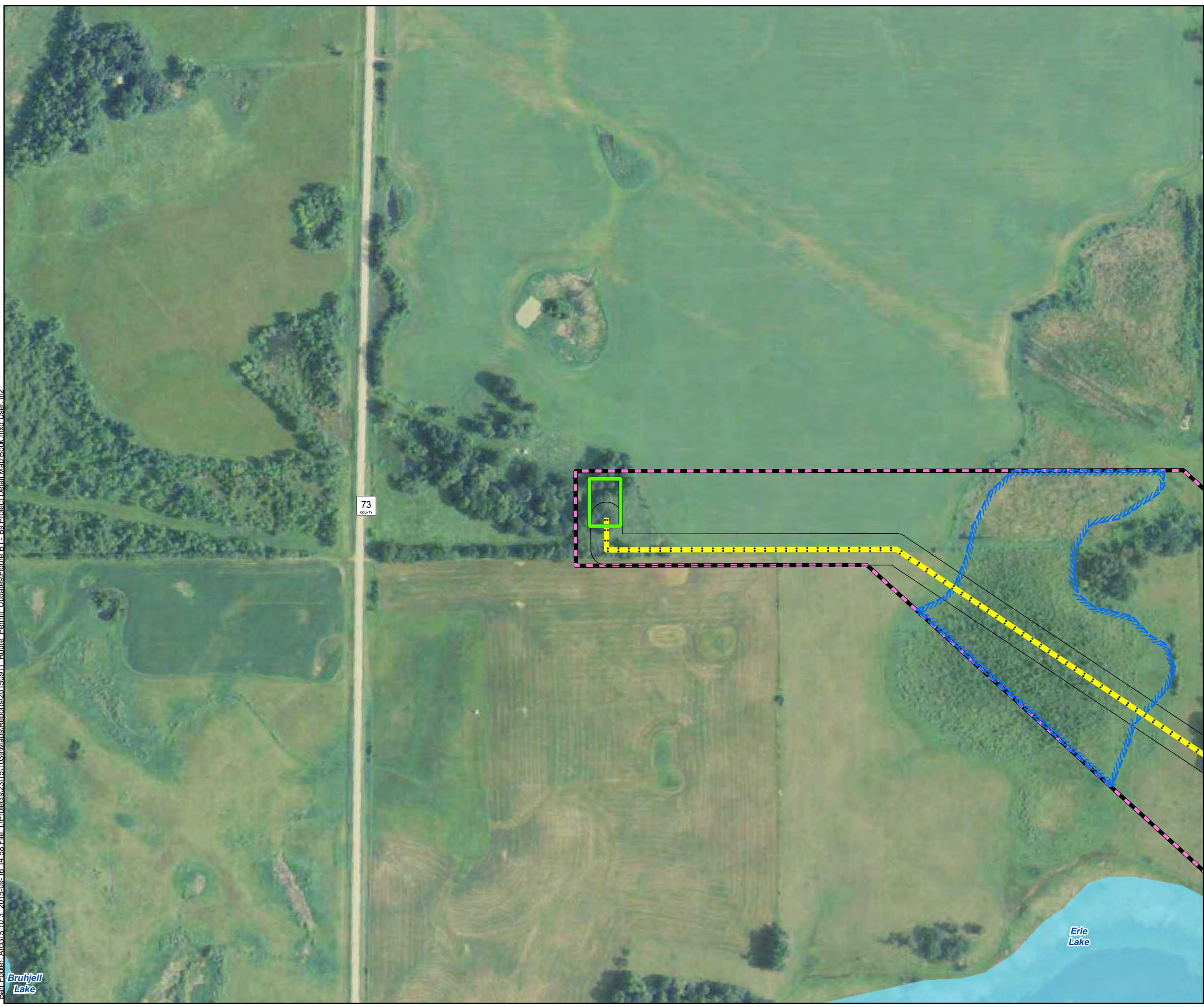

- Constructed Switch Connection Point
- Existing Substation Location
- Clearbrook West Substation Footprint
- Buildings by Type**
- ◆ Non-Residential
- Silo
- Tank
- - - Anticipated Alignment
- Existing Distribution and Transmission Lines**
- - - Low Voltage Distribution
- - - 115 kV
- ~ PWI Watercourse
- PWI Basin
- NWI Wetland
- Anticipated 100ft ROW
- Anticipated Route Width

Image Source: 2013 Farm Service Agency

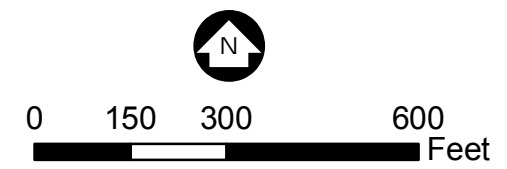

Figure B-9

Map 9 of 9
 PROJECT DETAIL MAP BOOK
 Proposed Clearbrook – Clearbrook West
 115 kV HVTL Project
 Minnkota Power
 Clearwater County, MN



Appendix C

Environmental Feature and Resource Maps

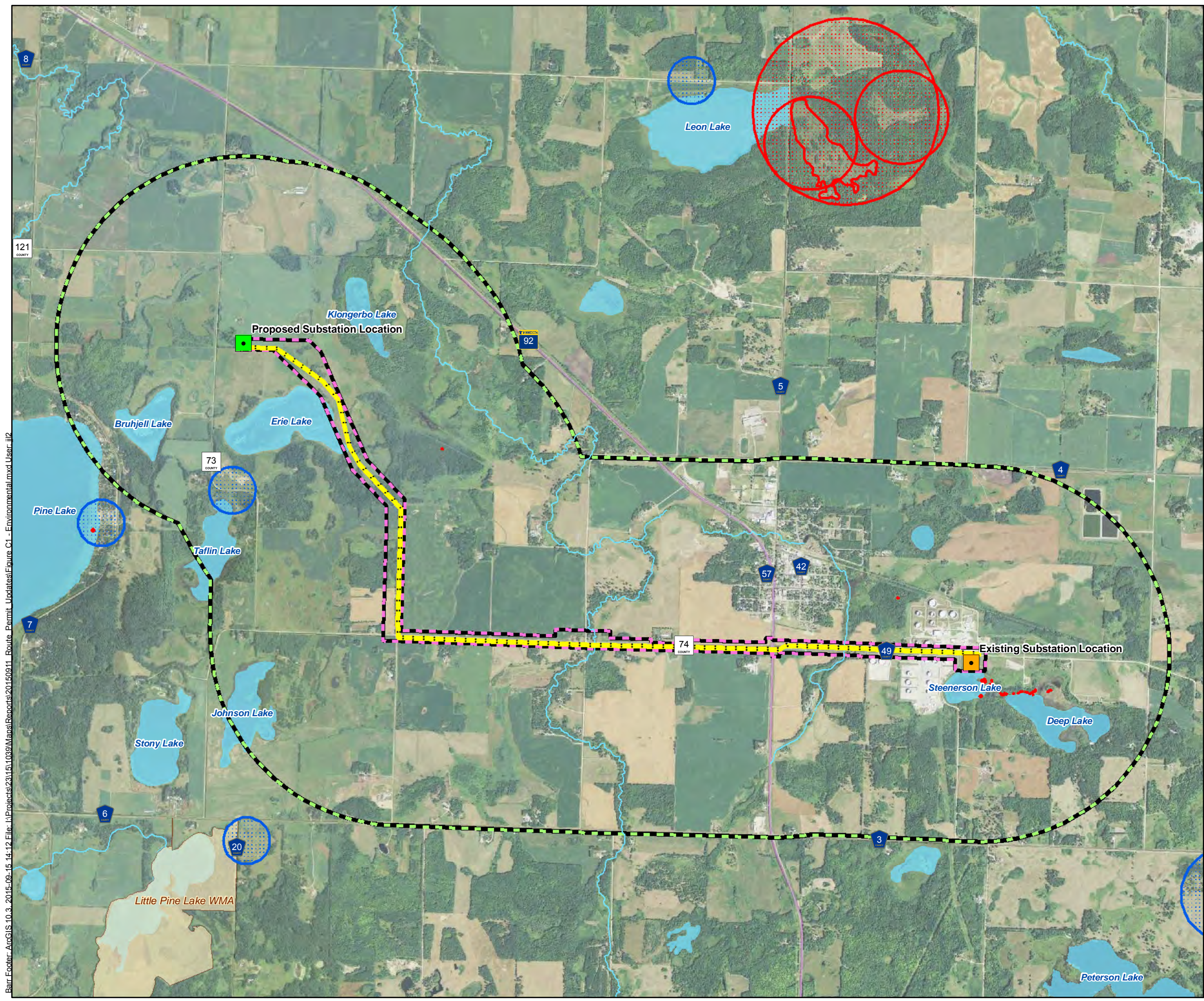

- Existing Substation Location
- Proposed Substation Location
- Anticipated Alignment
- Anticipated Route Width
- 1 Mile Buffer
- PWI Basin
- PWI Watercourse
- Wildlife Management Area
- NHIS Rare Natural Features***
- Vertebrate Animal
- Community
- Invertebrate Animal
- Vascular Plant
- Nonvascular Plant; Fungus
- Animal Assemblage
- Geologic

* Natural Heritage Information System Rare Features Data
 Copyright 2012 State of Minnesota, Department of Natural Resources

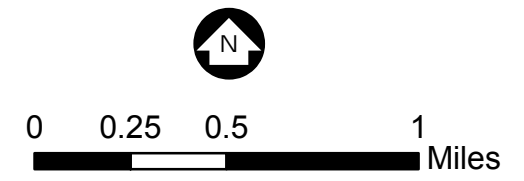
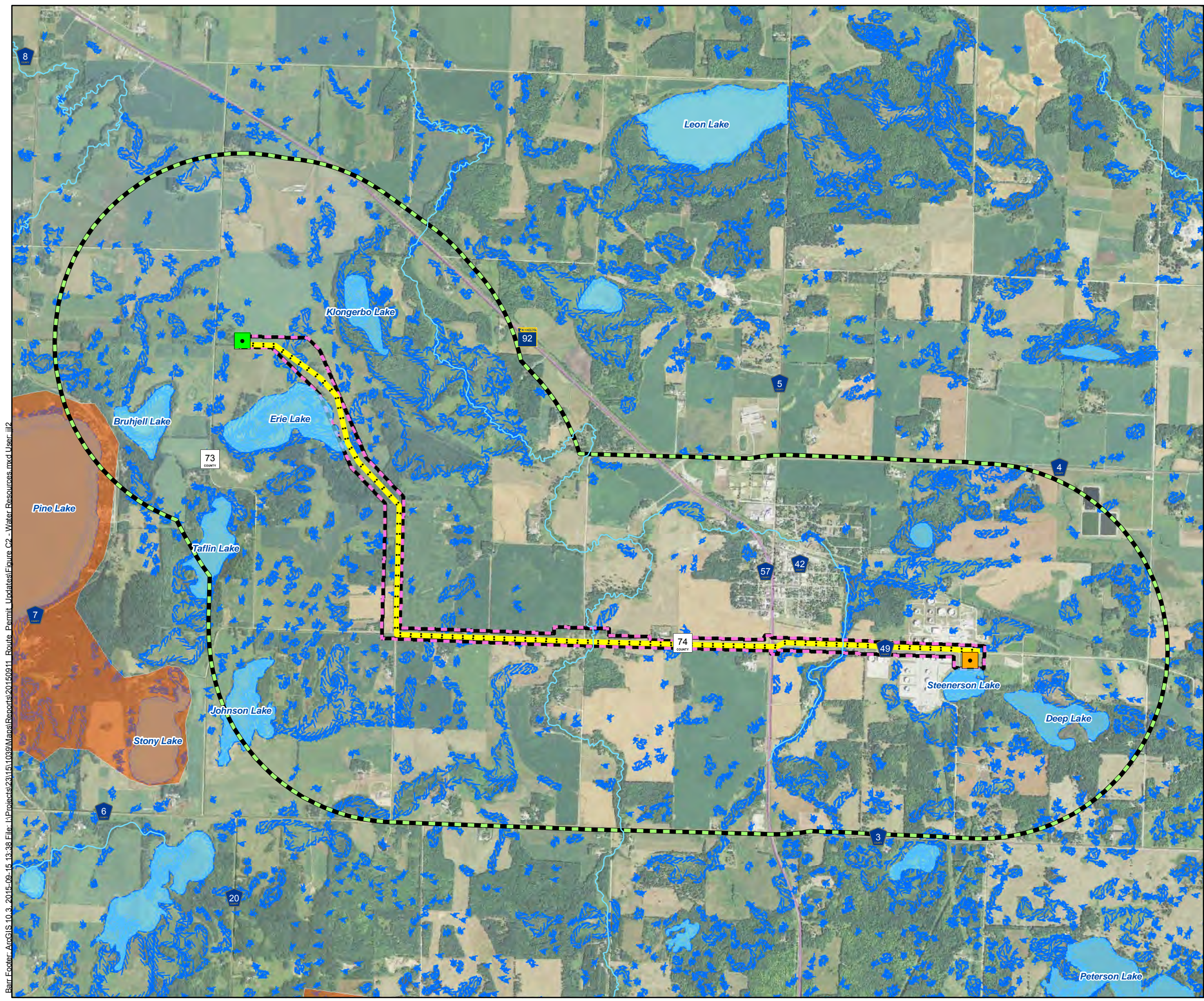

Figure C-1

ENVIRONMENTAL
 Proposed Clearbrook – Clearbrook West
 115 kV HVTL Project
 Minnkota Power
 Clearwater County, MN

Barr Footer: ArcGIS 10.3, 2015-09-15 14:12 File: I:\Projects\23115\10391\Map\Reports\20150911_Route_Permit_Updates\Figure_C1_Environmental.mxd User: jlj2



- Existing Substation Location
- Proposed Substation Location
- - - Anticipated Alignment
- - - Anticipated Route Width
- 1 Mile Buffer
- Groundwater Sensitivity to Class V Wells
- ~ PWI Watercourse
- PWI Basin
- ~ NWI Wetlands

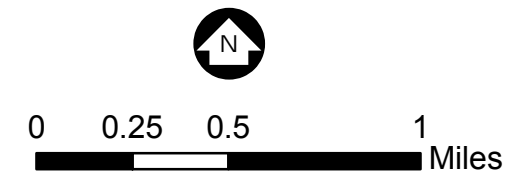
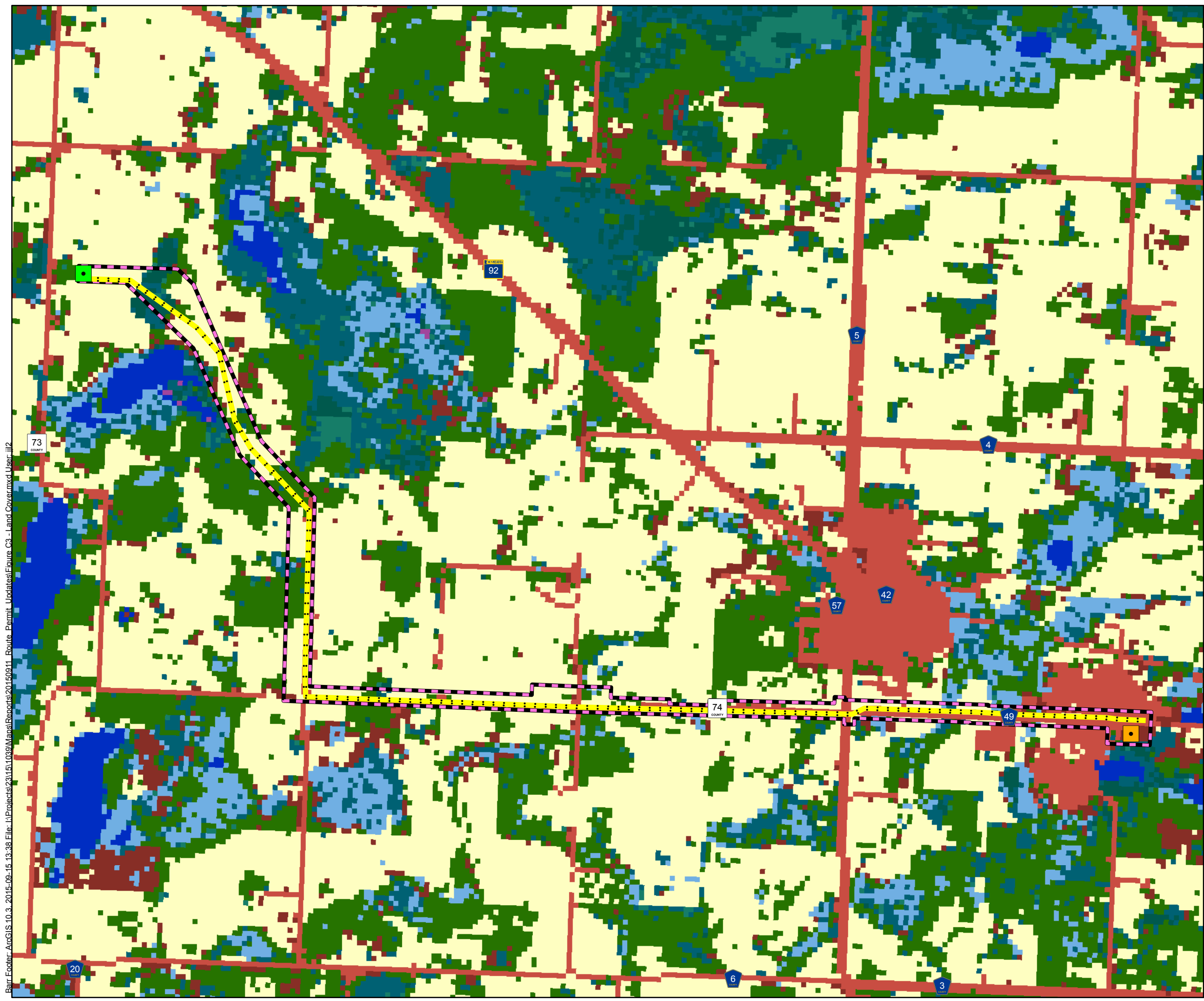

Figure C-2

WATER RESOURCES
 Proposed Clearbrook – Clearbrook West
 115 kV HVTL Project
 Minnkota Power
 Clearwater County, MN

Barr Footer: ArcGIS 10.3, 2015-09-15 13:38 File: I:\Projects\23115\10391\Map\Reports\20150911_Route_Permit_Updates\Figure_C2_Water_Resources.mxd User: jll2



- Existing Substation Location
 - Proposed Substation Location
 - Anticipated Alignment
 - Anticipated Route Width
- USGS GAP Data - Level 04 (NVC Division)***
- Developed & Urban
 - Eastern North America Freshwater Wet Meadow, Riparian & Marsh
 - Eastern North American Cool Temperate Forest
 - Eastern North American Flooded & Swamp Forest
 - Great Plains Grassland & Shrubland
 - Herbaceous Agricultural Vegetation
 - Introduced & Semi Natural Vegetation
 - North American Boreal Flooded & Swamp Forest
 - North American Boreal Forest
 - Open Water
 - Recently Disturbed or Modified
 - Southeastern North American Flooded & Swamp Forest

* USGS National Gap Analysis Program

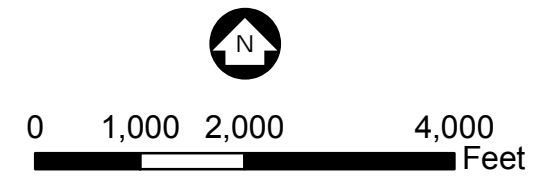
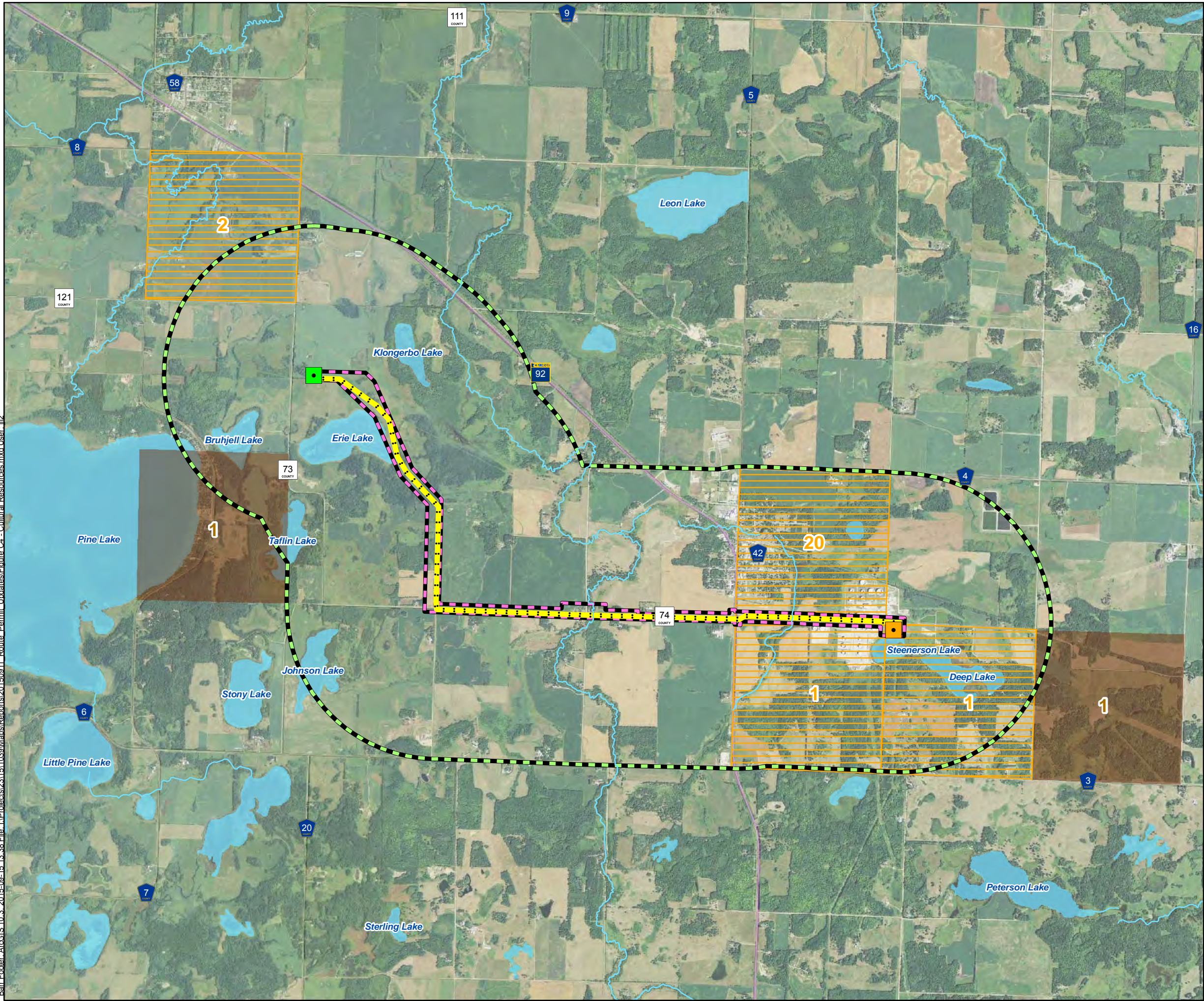











Figure C-3

LAND COVER
 Proposed Clearbrook – Clearbrook West
 115 kV HVTL Project
 Minnkota Power
 Clearwater County, MN

Barr Footer: ArcGIS 10.3, 2015-09-15 13:38 File: I:\Projects\2315\1039\Manis\Reports\20150911_Route_Permit_Updates\Figure_C3_LandCover.mxd User: jll2

Barr Footer: ArcGIS 10.3, 2015-09-15 13:38 File: I:\Projects\2315\10391\Maps\Reports\20150911_Route_Permit_Updates\Figure_C4 - Cultural Resources.mxd User: jil2



-  Existing Substation Location
-  Proposed Substation Location
-  Anticipated Alignment
-  Anticipated Route Width
-  1 Mile Buffer
-  PWI Basin
-  PWI Watercourse
-  PLS Section with Historic Site
-  PLS Section with Archaeological Site

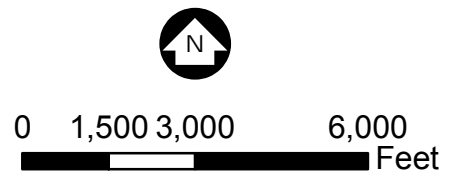

Figure C-4
 CULTURAL RESOURCES
 Proposed Clearbrook – Clearbrook West
 115 kV HVTL Project
 Minnkota Power
 Clearwater County, MN

Appendix D
Landowner List

| Property Tax ID | Landowner Name | Section | Township | Range |
|-----------------|---|---------|----------|-------|
| R16.036.0110 | MOORE RICKY & DIANNE | 36 | 149 | 38 |
| R16.036.0100 | MOORE DIANE | 36 | 149 | 38 |
| R16.036.0120 | OSMONSON RONALD | 36 | 149 | 38 |
| R16.036.0700 | MAST JAKE H & PRISCILLA N | 36 | 149 | 38 |
| R16.023.0300 | ENBRIDGE PIPELINE NORTH DAKOTA & ATTN: DUFF & PHELPS | 23 | 149 | 38 |
| R16.023.0600 | MAST JAKE H & PRISCILLA N | 23 | 149 | 38 |
| R16.025.0210 | ANDERSON THOMAS A & CORRINNE | 25 | 149 | 38 |
| R16.026.0100 | MAST JAKE H & PRISCILLA N | 26 | 149 | 38 |
| R16.023.0200 | ERIE HARVEY R | 23 | 149 | 38 |
| R12.033.0600 | OTTER TAIL POWER COMPANY & SERVING LAKEHEAD PIPELINE | 33 | 149 | 37 |
| R12.031.0100 | ANDERSON THOMAS A & CORRINNE | 31 | 149 | 37 |
| R12.028.0600 | ENBRIDGE PIPELINE NORTH DAKOTA & ATTN: DUFF & PHELPS | 28 | 149 | 37 |
| R12.029.2100 | ENBRIDGE PIPELINE NORTH DAKOTA & ATTN: DUFF & PHELPS | 29 | 149 | 37 |
| R12.029.2000 | ENBRIDGE PIPELINE NORTH DAKOTA & ATTN: DUFF & PHELPS | 29 | 149 | 37 |
| R16.025.0200 | JOHNSON JEFF, BECKY & ROSALIND JOHNSON C/O VERNON E JOHNSON | 25 | 149 | 38 |
| R12.029.1100 | MINNESOTA PIPELINE CO | 29 | 149 | 37 |
| R12.031.0120 | ANDERSON THOMAS A & CORRINNE | 31 | 149 | 37 |
| R12.031.0110 | GUSTAFSON & GOUDGE HOLDINGS LLC | 31 | 149 | 37 |
| R16.026.0600 | MAST JAKE H & PRISCILLA N | 26 | 149 | 38 |
| R16.026.0500 | MAST JAKE H & PRISCILLA N | 26 | 149 | 38 |
| R16.026.0210 | JOHNSON JEFF, BECKY & ROSALIND JOHNSON C/O VERNON E JOHNSON | 26 | 149 | 38 |
| R12.032.0500 | ANDERSON JONATHAN | 32 | 149 | 37 |

Appendix E

Cultural Resources Review

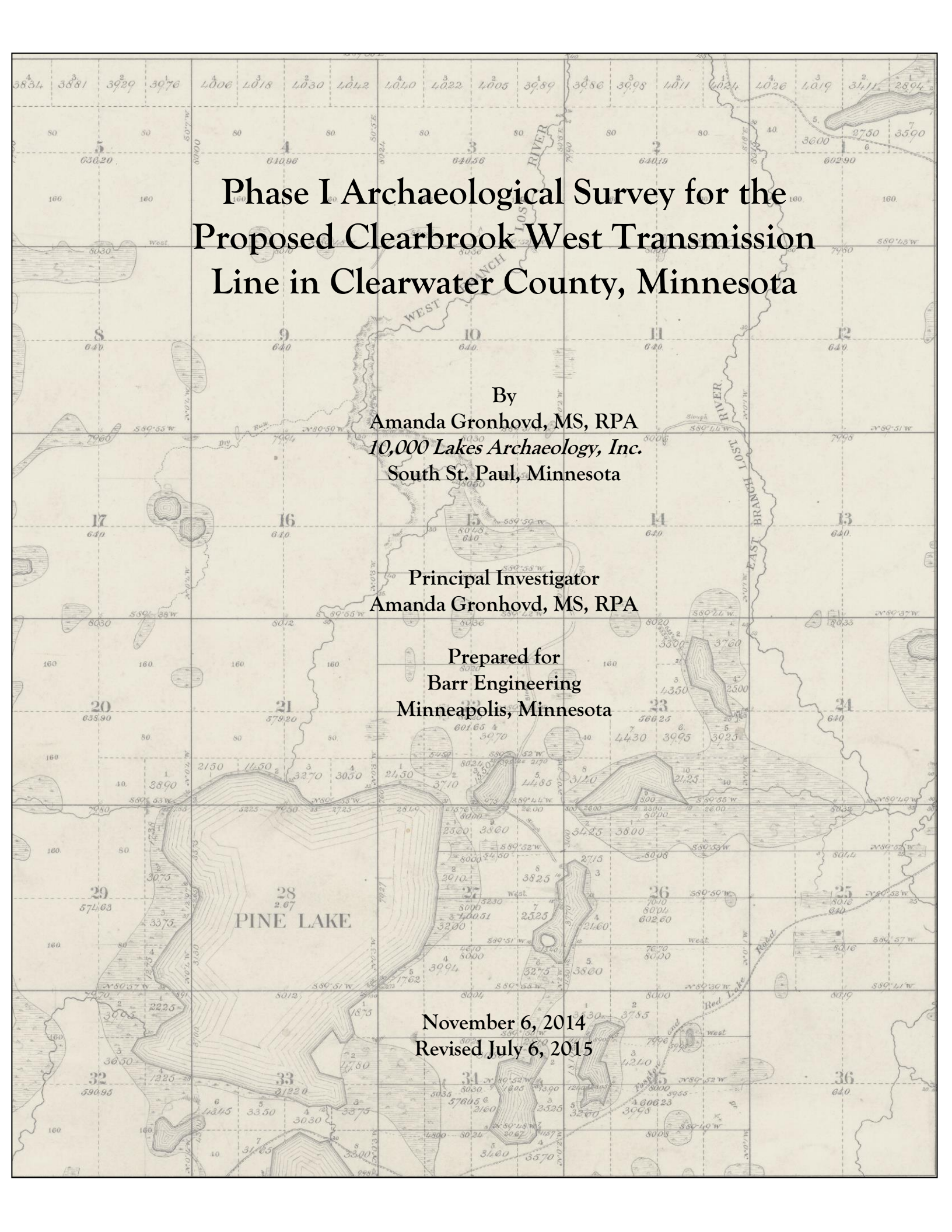

Phase I Archaeological Survey for the Proposed Clearbrook West Transmission Line in Clearwater County, Minnesota

By
Amanda Gronhovd, MS, RPA
10,000 Lakes Archaeology, Inc.
South St. Paul, Minnesota

Principal Investigator
Amanda Gronhovd, MS, RPA

Prepared for
Barr Engineering
Minneapolis, Minnesota

November 6, 2014
Revised July 6, 2015

MANAGEMENT SUMMARY

Minnkota Power Cooperative, Inc. (“Minnkota Power”) is planning to build a new 5.3-mile long, 115 kilovolt (kV) electric transmission line and a new 115/4.16 kV substation. The proposed project will start in Leon Township by tapping an existing 115 kV line via construction of a 1-way switch and the proposed project will end in Pine Lake Township at the new 115/4.16 kV substation. The proposed project is needed to serve a single industrial load in the Clearbrook, Minnesota area. The proposed project is located in T149N, R37W, Sections 28, 29, 30, 31, 32, and 33; and T149N, R38W, Sections 23, 25, 26, 35, and 36 in Clearwater County, Minnesota.

Barr Engineering contracted with *10,000 Lakes Archaeology, Inc.* to conduct a Phase I archaeological survey of high potential locations for this proposed project. The survey took place October 20-24, 2014, and located no previously unrecorded archaeological sites. One recorded site is located at the far western end of the project corridor. This site was determined *not potentially eligible* for the National Register of Historic Places in 2014. Based on the results of the survey, *10,000 Lakes Archaeology* recommends that the project, as proposed, will not affect any archaeological resources. However, two cemeteries are within the Area of Potential Effect (APE). Thus, *10,000 Lakes Archaeology* recommends that the two cemeteries be avoided, and that the project be allowed to proceed as planned.

TABLE OF CONTENTS

| | |
|--|----|
| Management Summary | 1 |
| Introduction | 4 |
| Cultural History | 5 |
| Pre-Contact Period | 5 |
| Contact/Postcontact Period (1630 to Present) | 8 |
| Background Research | 10 |
| Archaeological Fieldwork | 12 |
| Methods | 12 |
| Results | 12 |
| Recommendations | 31 |
| Bibliography | 32 |
| Appendix A: Letter from the State Historic Preservation Office | 33 |

FIGURES

| | |
|--|----|
| Figure 1. Location of the proposed Clearbrook West Transmission Line (blue) showing APE (yellow). | 4 |
| Figure 2. Paleoindian projectile points (Eddins n.d.). | 6 |
| Figure 3. Woodland ceramic pots (MVAC n.d.). | 7 |
| Figure 4. Father Hennepin at St. Anthony Falls (Minnesota Historical Society 1903) | 8 |
| Figure 5. Logging at St. Anthony Falls (Minnesota Historical Society 1870). | 9 |
| Figure 6. Survey areas (blue) and recorded archaeological sites (red) within ½-mile of the APE (yellow). | 11 |
| Figure 7. Survey areas (blue) and APE (yellow). | 13 |
| Figure 8. Survey Areas 1 and 2 showing APE (yellow) and survey areas (gray). | 14 |
| Figure 9. Silver Creek Cemetery in the southern portion of Area 1, looking east. | 14 |
| Figure 10. Area 1, looking east. | 15 |
| Figure 11. Areas 3, 4, and 5 showing APE (yellow) and survey areas (gray). | 16 |
| Figure 12. Areas 3 and 4 showing APE (yellow), survey areas (gray), and shovel test locations. | 17 |
| Figure 13. Cemetery in Area 5, looking west. | 18 |
| Figure 14. Cornfield in Area 5, looking northwest. | 18 |
| Figure 15. Alfalfa field in Area 5, looking southwest. | 19 |
| Figure 16. Area 5 showing shovel test locations. | 20 |
| Figure 17. Areas 6 and 7 showing APE (yellow) and survey areas (gray). | 21 |
| Figure 18. Eastern portion of Area 6, looking northeast. | 21 |
| Figure 19. Area 6, looking west. | 22 |
| Figure 20. Area 6 showing shovel test locations. | 23 |
| Figure 21. Area 8 showing APE (yellow) and survey areas (gray). | 24 |
| Figure 22. Photograph from Area 8, looking west. | 25 |
| Figure 23. Photograph of Area 8, looking west. | 25 |
| Figure 24. Area 8 showing shovel test locations. | 26 |
| Figure 25. Area 9 showing location of archaeological site 21CE0079. | 27 |
| Figure 26. Surface features at site 21CE0079, facing southeast. | 28 |
| Figure 27. Structural remains at site 21CE0079, facing east. | 28 |
| Figure 28. Structural remains at site 21CE0079, facing southeast. | 29 |
| Figure 29. Remains of the possible barn foundation at site 21CE0079, facing southeast. | 30 |
| Figure 30. Map showing original (solid red) and revised (blended red) site 21CE0079 boundaries. | 31 |

TABLES

| | |
|--|----|
| Table 1. Cultural resources located within 1½ miles of the proposed project area. | 11 |
|--|----|

Phase I Archaeological Survey for the
Proposed Clearbrook West Transmission Line in
Clearwater County, Minnesota

INTRODUCTION

Minnkota Power Cooperative, Inc. (“Minnkota Power”) plans to build a 5.3-mile long, 115 kilovolt (kV) electric transmission line and 115/4.16 kV substation. The project starts in Leon Township by tapping an existing 115 kV line via construction of a 1-way switch and will end in Pine Lake Township at the new 115/4.16 kV substation. The proposed project will serve a single industrial load in the Clearbrook, Minnesota area.

This project extends from south of Clearbrook, in the southwestern corner of Section 28, T149N, R37W west along the southern edges of Sections 29 and 30 (northern edges of Sections 31 and 32) into T149N, R38W. Here the line runs along the southern edge of Section 25 (northern edge of Section 36), then turns north along the eastern edge of Section 26, passing through the northeastern corner of Section 26 and into the southwestern portion of Section 23. The line terminates near the western edge of Section 23 (T149N, R38W) (USGS 7.5 Topo Clearbrook, Minn. 1969) (Figure 1). The proposed corridor for the proposed project varies from approximately 300 to 500 feet wide.

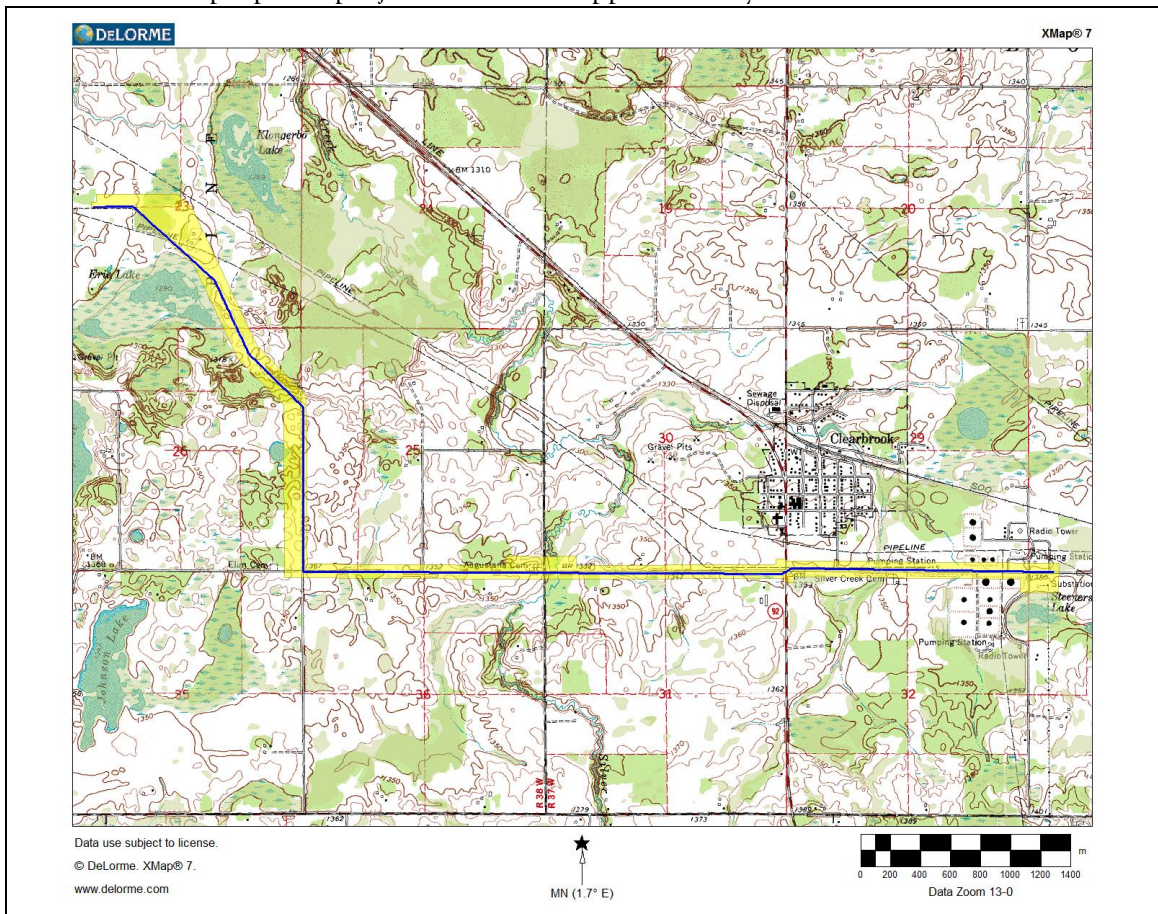

Figure 1. Location of the proposed Clearbrook West Transmission Line (blue) showing APE (yellow).

Cultural History

The Minnesota State Historic Preservation Office (SHPO) has developed several historic contexts for the state of Minnesota and the Upper Midwest. These contexts examine Minnesota's recent (historic) and distant (precontact) past and are based on decades of archaeological and historic research. They are designed to help generally describe and interpret the history of the state and give basic insight into the prevailing theories pertaining to the precontact and historic communities existing in specific locations and at discrete points of time.

The cultural histories focusing solely on American Indian communities are divided into three major traditions: Paleoindian, Archaic, and Woodland. These traditions are defined on the basis of significant changes in how American Indian communities lived. The cultural histories that integrate American Indian and Euroamerican history are generally divided into the Contact and Post-Contact Periods. These contexts range from the first contact between Europeans and American Indians during European exploration in the region, through Euroamerican settlement of traditionally American Indian lands.

The proposed project is located within Archaeological Region 5w (Anfinson 1990). The region consists of hilly terminal moraines as well as ground moraines, outwash plains, and lake plains. Historically, white, jack, and red pines dominated the vegetation, with large pockets of elm, maple, basswood, ash, oak, aspen, and birch. The region also contained significant wild rice beds, and was home to deer, beaver, moose, black bear, waterfowl, and fish (Anfinson 1990: 148-149). Generally, pre-contact American Indians chose habitation sites adjacent to major lakes and rivers, especially at stream intersections in near wild rice beds (Anfinson 1990: 158).

Pre-Contact Period

Paleoindian Tradition (12,000 to 8,000 Before Present [B.P.]

The Paleoindian Tradition refers to the period at the close of the Pleistocene and into the Holocene when American Indian communities were small, mobile, and focused on hunting. Archaeological evidence from Paleoindian sites throughout central United States and Canada indicates that these communities hunted a limited number of large animals in a variety of environmental settings. As the Pleistocene ended and the Holocene began, the megafauna (e.g., mammoth) gradually died out. This caused the Paleoindian people to shift their focus to primarily hunting the largest remaining species, bison. In addition to bison, it is likely that gathering wild plant foods and hunting smaller animals also contributed significantly to the diet of the Paleoindian people.

The distinctive stone tools made by the Paleoindians included large lanceolate projectile points, which changed through time (Figure 2). The projectile points that were made by the early Paleoindians are often fluted, meaning a channel was created from the base running up the middle of the point (see Clovis and Folsom in Figure 3), as opposed to those made later which were not (see Plainview in Figure 4). Because Paleoindian communities were very small and nomadic, archaeologists have found only sparse, scattered evidence of the Paleoindian people.

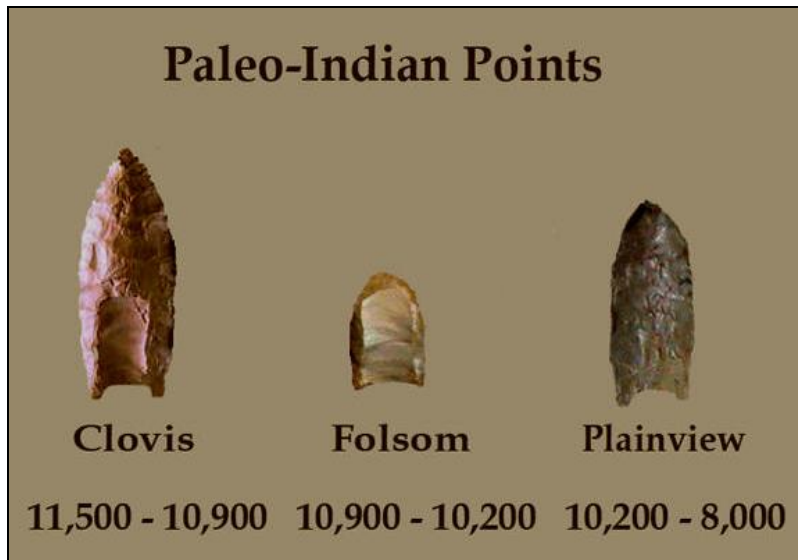

Figure 2. Paleoindian projectile points (Eddins n.d.).

Archaic Tradition (8,000 to 2,800 B.P.)

Shifts in diet and settlement patterns define the transition to the Archaic Tradition. During this period, archaeological evidence suggests that native people were adapting to environmental changes by using more diverse plant and animal resources, and creating and using a broader range of tools including new projectile point forms, atlatls (spear thrower that allowed spears to be thrown farther and with more force), copper tools and ground and pecked stone tools. Although some research suggests that community size increased during the Archaic period, other archaeological evidence counters that assumption, suggesting that community sizes remained small and that day-to-day activities took place at a series of seasonal camps (Anfinson 1987; 1997).

During this period, Archaic people began developing regional differences within their material culture. In Minnesota, this variation appears to have been tied to the natural environment, specifically the plant communities. These variations focused on the "Plains Archaic" in the western prairies, "Eastern Archaic" in the deciduous forest, "Lake-Forest Archaic" in the transitional zone between the deciduous and boreal forest areas, and the

"Shield Archaic" in the boreal forest areas of the northeast. As with Paleoindian sites, Archaic sites are relatively small and ephemeral.

Woodland Tradition (2,800 B.P. to European Contact)

Throughout the Midwest, the Woodland Tradition is generally divided into three periods: Early, Middle and Late; however, Anfinson (1987) has suggested that a division into Initial and Terminal periods might be more appropriate in Minnesota. Archaeological research indicates that in many ways, life for communities during the Woodland Tradition remained similar to those of the Archaic period, with a dependence upon a diverse, seasonal resource base of plants and animals (Anfinson 1987:222; Johnson 1988). The transition to the Initial Woodland Tradition occurred when American Indians began manufacturing ceramic vessels, using bows and arrows, constructing earthen burial mounds, and cultivating and harvesting select plant species. The adoption of ceramics by the Woodland American Indians might have caused significant changes in many aspects of this culture, the foremost being subsistence strategies (Boszhardt et al. 1986:258) (Figure 3).

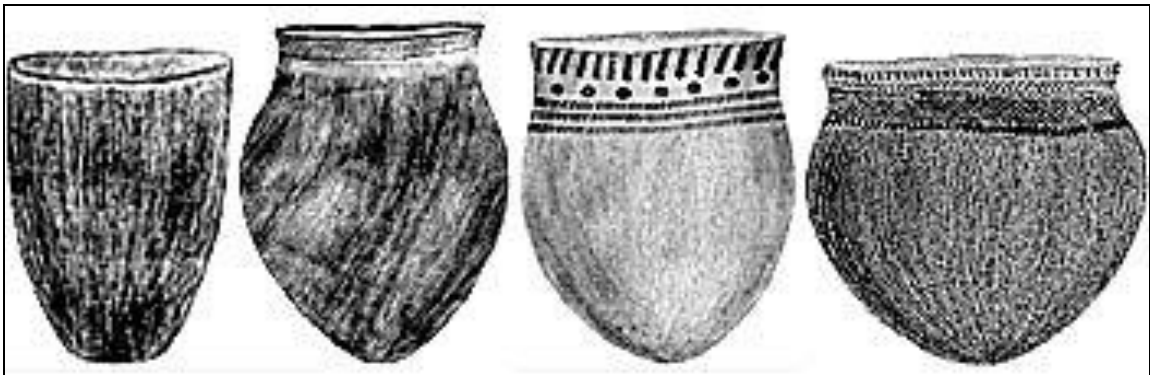

Figure 3. Woodland ceramic pots (MVAC n.d.).

Populations began to grow, marking the transition into the Late or Terminal Woodland period. Settlement patterns shift to larger, more permanent villages typically located near rivers. One possible reason for this is that toward the end of Woodland Period, American Indians became increasingly efficient in how they acquired food. The subsistence strategies of these people incorporated hunting and gathering with limited agriculture focusing on specific plants. Ceramic vessels differed from previous types in form and decoration. Woodland period communities were situated in locations that ranged from focusing on a specific resource to general environments capable of sustaining a large community for a long time.

Site types assigned to the Woodland Tradition throughout the region range from cemeteries and small, limited use sites to extensive village and habitation sites.

Contact/Postcontact Period (1630 to Present)

This period generally refers to the span of time extending from the first European explorations until intensive Euroamerican settlement of the region. Minnesota's historical period began in 1673 when French explorers Marquette and Joliet discovered the upper portion of the Mississippi River. Ten years later, Catholic Missionary Father Louis Hennepin returned to France to write the first book about Minnesota, *Description de la Louisiane*, telling his story of exploring Minnesota and of being held captive by the Dakota Indians (Figure 4).



Figure 4. Father Hennepin at St. Anthony Falls (Minnesota Historical Society 1903)

The territory containing modern-day Minnesota was claimed by Spain, France, Great Britain, and eventually the United States. Lieutenant Zebulon Montgomery Pike led the first United States expedition through Minnesota in 1805. Fort St. Anthony (later Ft. Snelling) was completed between 1819 and 1824, and in 1836, the Wisconsin Territory, including a portion of Minnesota, was formed. Minnesota became a territory in 1849 and achieved statehood on May 11, 1858. The fur trade drove much of the European exploration and settlement in Minnesota through the mid-1800s.

As white settlers came to Minnesota, the state's economy and numerous industries began developing. One of the earliest industries to peak in Minnesota was the lumber industry (Figure 5). The extensive white pine forests of northern Minnesota brought industrialists, capital, and settlers to the state. Lumbering peaked between 1899 and 1905 and eventually the loggers moved out of Minnesota as the forests were obliterated.



Figure 5. Logging at St. Anthony Falls (Minnesota Historical Society 1870).

Agriculture, specifically wheat farming, was also a key industry in Minnesota. The huge wheat farms in central western and southern Minnesota caused mills to spring up along waterways across the state. The most notable milling center was Minneapolis, which ultimately dominated the world in wheat and flour processing until the 1930s.

In addition to lumber and milling, Minnesota was also a leader in iron mining. Looking at the industries and economy of northeastern Minnesota today, one might have difficulty imagining the area prior to the iron ore industry. Mining and the iron industry created the towns, built the roads, and brought the people to the heavily wooded and remote northeastern Minnesota of the late 19th century. Iron ore shipments were sent from Michigan's Upper Peninsula nearly three decades earlier, but once the Minnesota iron lodes were discovered, the state quickly established a dominant position atop the iron ore production hierarchy.

Associated archaeological and historic site types categorized in the Contact/Postcontact Period include standing structures as well as archaeological sites.

Background Research

In the summer of 2014, *10,000 Lakes Archaeology* conducted a background research for the proposed project area to determine if the APE contained or is likely to contain archaeological sites (Gronhovd 2014). During the background research, *10,000 Lakes Archaeology* examined the Minnesota Archaeological Site Files, and the Minnesota Architectural History Site Files, and original land survey maps to determine if the proposed project might impact any archaeological sites.

This research revealed that six archaeological sites are recorded within approximately 1½ miles of the proposed project, four of which are within less than half a mile of the proposed project. During the background research, nine areas with moderate to high potential for unrecorded archaeological sites were also identified (Figure 6; Table 1). These locations were defined by considering many factors such as proximity to water, proximity to recorded archaeological sites, and topography. Archaeological sites are more likely to be found near water (including historic or precontact water bodies) and on prominent topographic features; however these are not the only locations archaeological sites could be located. Areas with low potential for archaeological sites include wetlands and areas with slopes over 20%. The areas with moderate to high potential for archaeological sites were surveyed as part of this project.

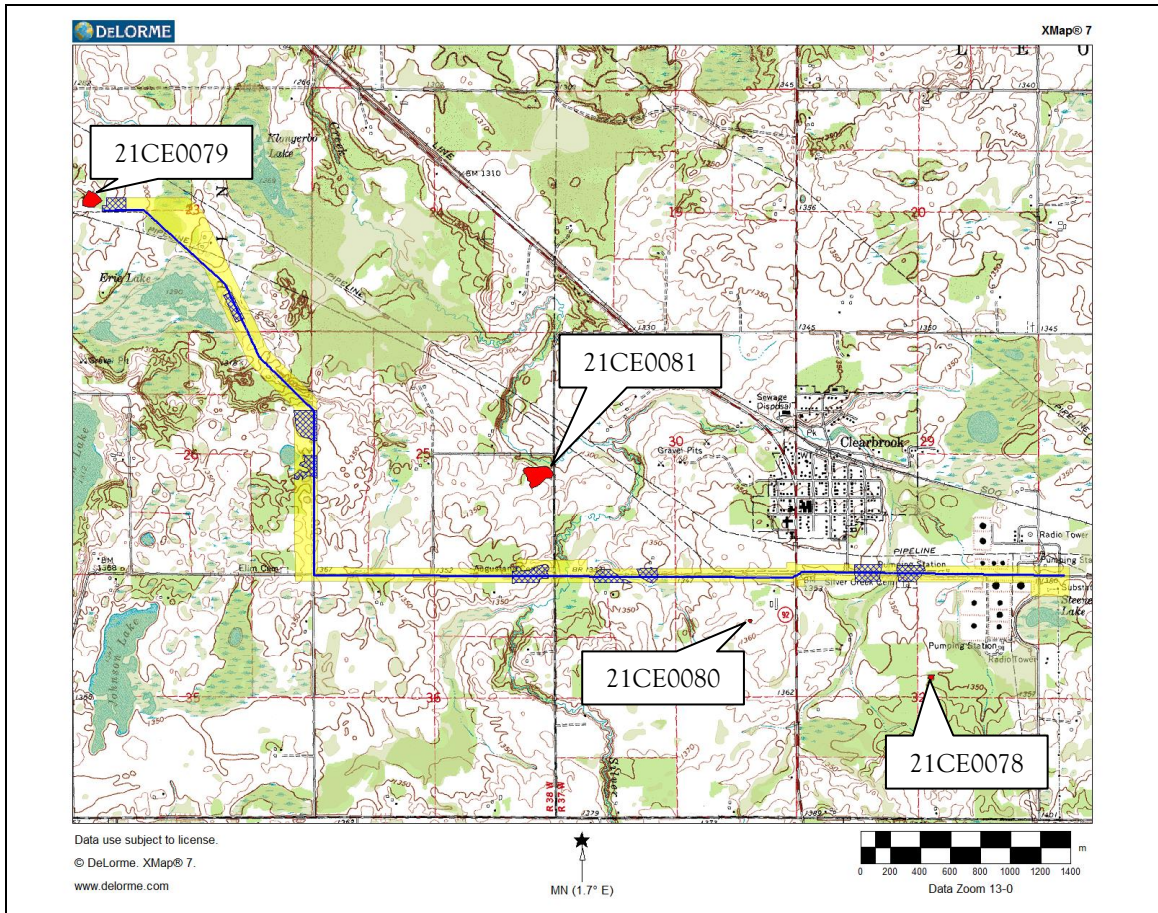

Figure 6. Survey areas (blue) and recorded archaeological sites (red) within 1/2-mile of the APE (yellow).

Table 1. Cultural resources located within 1 1/2 miles of the proposed project area.

| Site Type | State Site # | Location | Site description | Distance from Project Area |
|------------------------|--------------|----------------------|--|----------------------------|
| Historical Archaeology | 21CE0031 | T149N, R37W, Sec. 34 | Ruins of an historic farmstead with silo and windmill | 1 1/2 miles |
| Precontact Archaeology | 21CEq | T149N, R38W, Sec. 27 | Precontact ceramics were found at this location in 1938. Site has not been verified by archaeologists. | 1 1/2 miles |
| Precontact Archaeology | 21CE0078 | T49N, R37W, Sec. 32 | Single lithic | 1/2 mile |
| Historical Archaeology | 21CE0079 | T149N, R38W, Sec. 23 | Historic farmstead | Within APE |
| Precontact | 21CE0080 | T149N, R37W, | Single lithic tool | <1/4 mile |

| | | | | |
|---------------------------|----------|-------------------------|---------------|--------|
| Archaeology | | Sec. 31 | | |
| Historical Archaeology | 21CE0081 | T149N, R38W, Sec. 36 | Historic site | ½ mile |

Archaeological Fieldwork

Methods

The Phase I archaeological survey consisted of primarily pedestrian surface survey supplemented by shovel testing. The surface survey occurred in areas where more than 25% of the ground surface was visible, and involved walking over the area in five to 15-meter intervals while examining the ground surface for archaeological materials or features.

In wooded and grass-covered areas where less than 25% of the ground surface was visible, shovel testing was conducted. Shovel testing involved the excavation of test pits that measured 30 to 40 centimeters in diameter and were placed at 15-meter intervals or intuitively, as appropriate. As the soil was removed, it was screened through ¼-inch mesh hardware cloth to determine if cultural materials were present. Survey areas were photographed and all shovel tests were mapped using a hand-held GPS unit. Field surveys were consistent with the methods set forth in the *SHPO Manual for Archeological Projects in Minnesota* (Anfinson 2005).

Results

The survey examined nine separate areas identified as having a moderate to high potential for unrecorded archaeological sites. Each parcel surveyed is discussed below, beginning at the southeastern end and moving to the northwestern end.

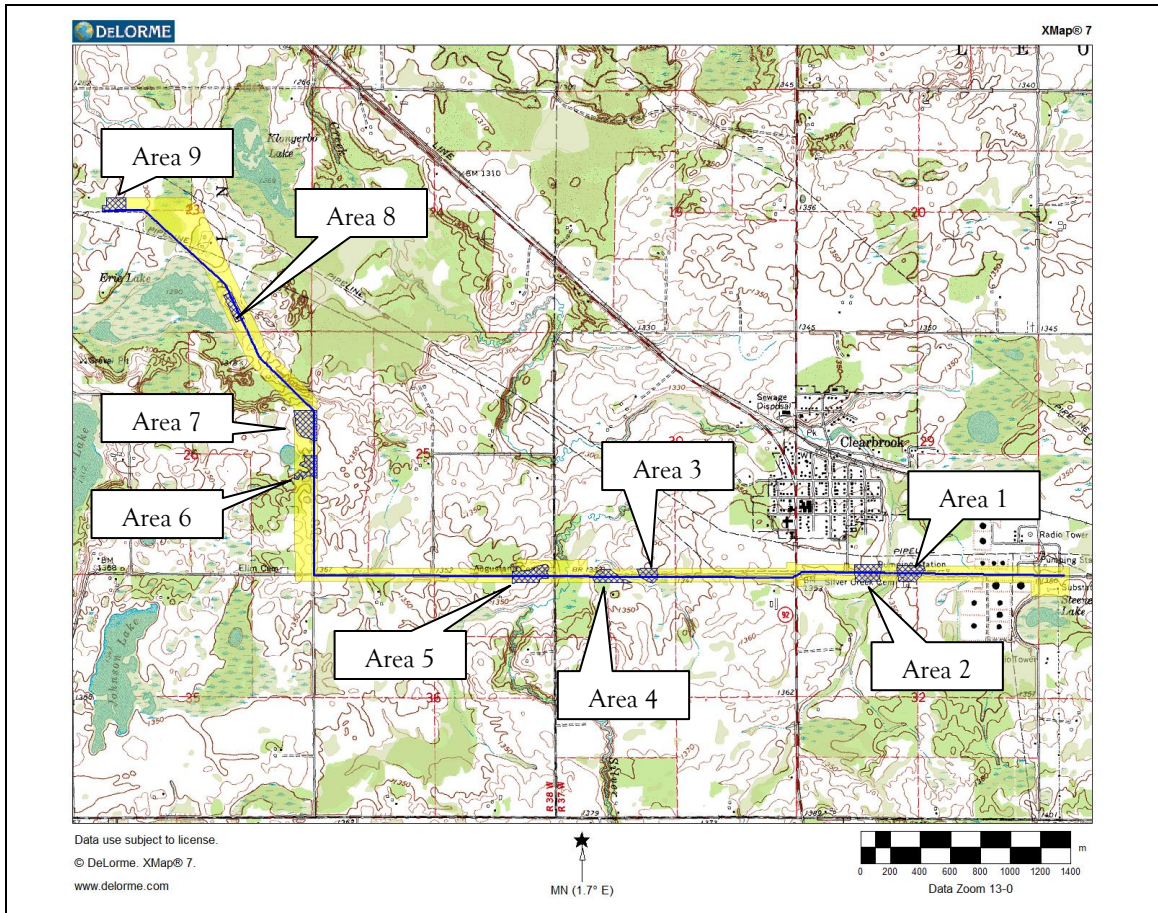

Figure 7. Survey areas (blue) and APE (yellow).

Areas 1 and 2

Areas 1 and 2 are located toward the eastern end of the proposed transmission line corridor, on the east and west sides of an intermittent/seasonal drainage (see Figure 7; Figure 8). The southern portion of Area 1 contains Silver Creek Cemetery (Figure 9). The earliest grave marker located in Silver Creek Cemetery dates to 1908, and the cemetery appears to remain in use.

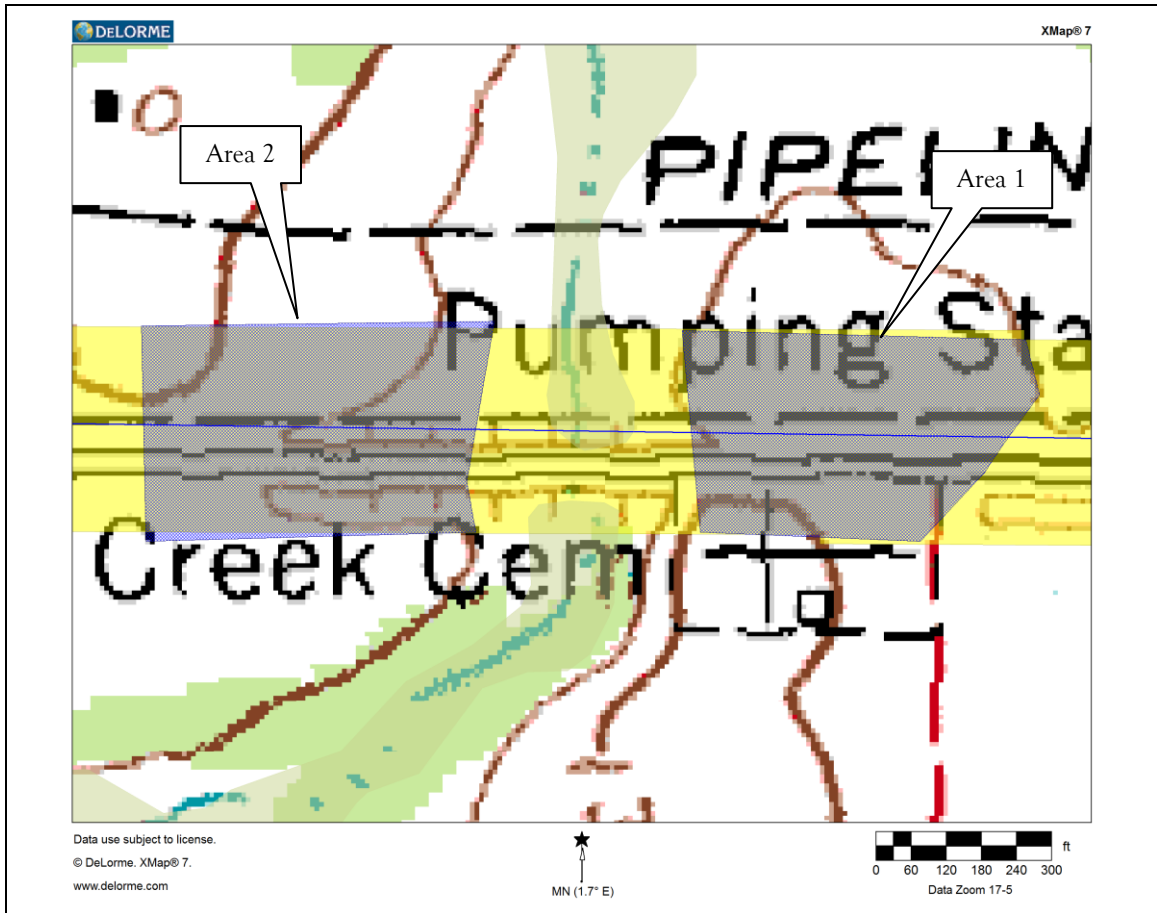

Figure 8. Survey Areas 1 and 2 showing APE (yellow) and survey areas (gray).

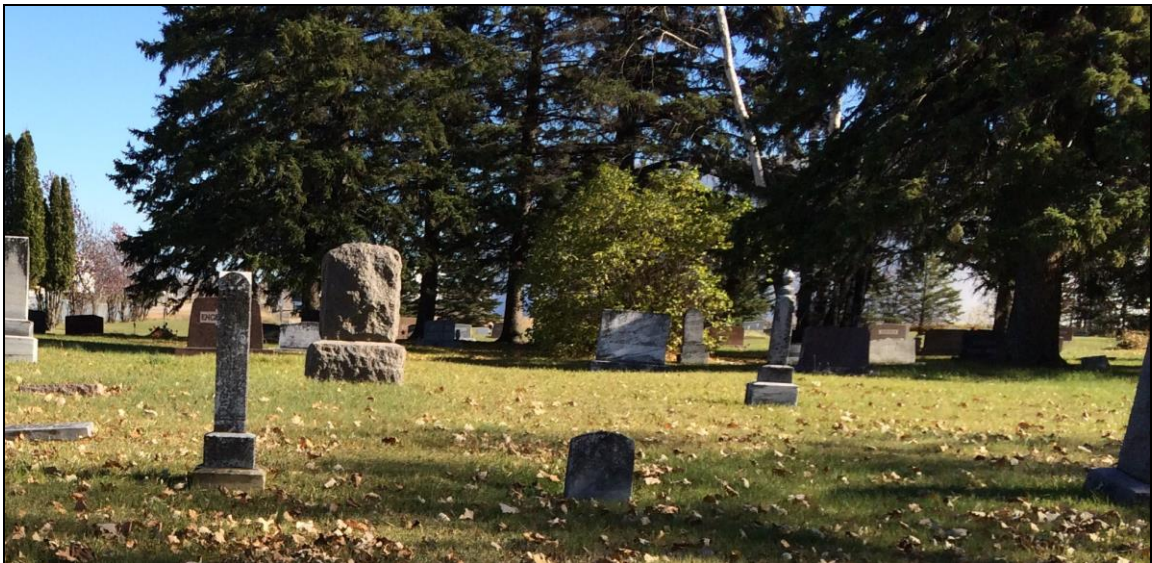

Figure 9. Silver Creek Cemetery in the southern portion of Area 1, looking east.

The northern portion of Area 1 and all of Area 2 consisted of plowed agricultural fields with excellent (>90%) surface visibility (Figure 10). These areas were pedestrian surface surveyed in 15-meter transects. No archaeological sites or features were identified during the survey of Areas 1 and 2.



Figure 10. Area 1, looking east.

Areas 3, 4, and 5

Areas 3, 4, and 5 are located southwest of Clearbrook, on three high spots between drainages (see Figure 7; Figure 11). Area 3 is located on the east side of an intermittent/seasonal drainage, with Area 4 on the west side of the seasonal drainage, and the east side of Silver Creek. Area 5 is located on the west side of Silver Creek.

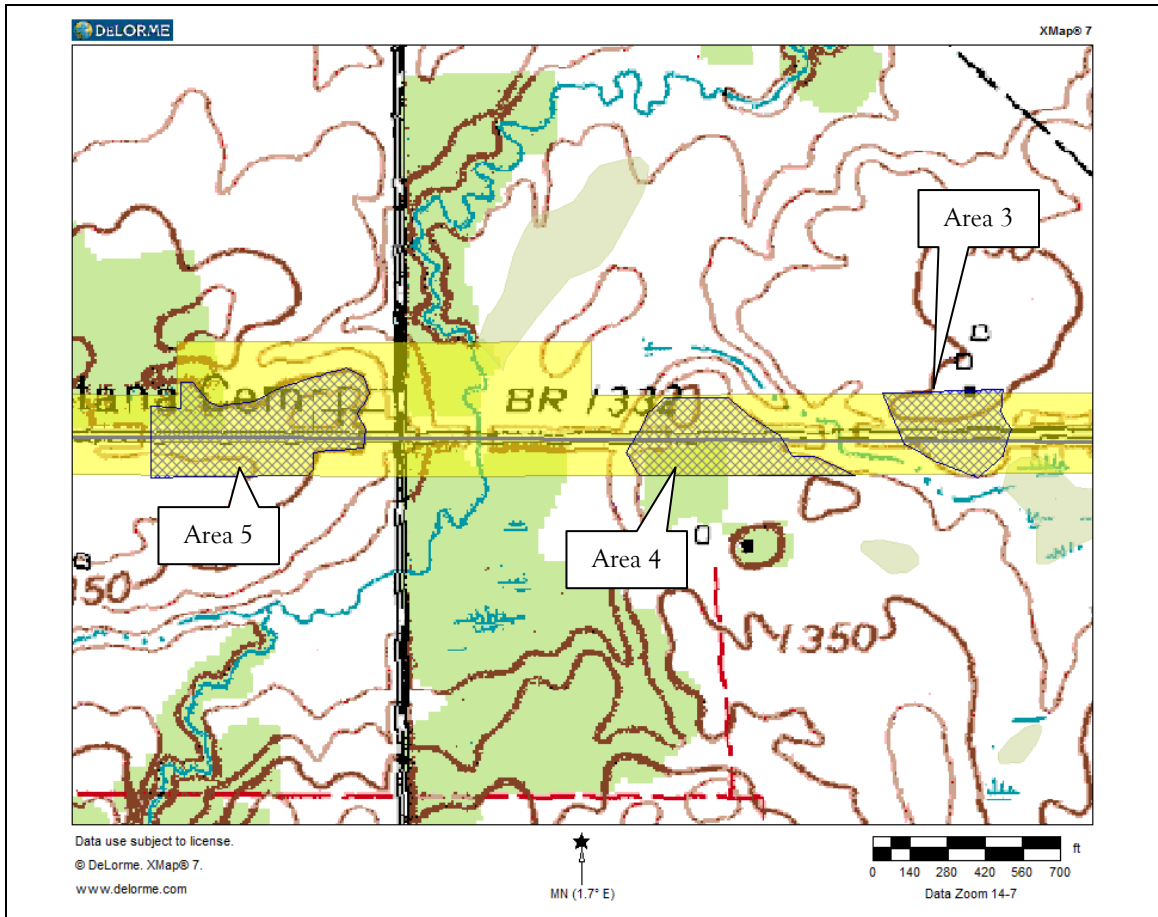

Figure 11. Areas 3, 4, and 5 showing APE (yellow) and survey areas (gray).

The south side of Area 3 consists of an alfalfa field, while the north side is a residential lawn. One shovel test was excavated on the south side of Area 3 in the alfalfa (Figure 12). The shovel test extended to a depth of 43 centimeters (cm) and consisted of approximately 20 cm of dark brown silt over very light brown silt.

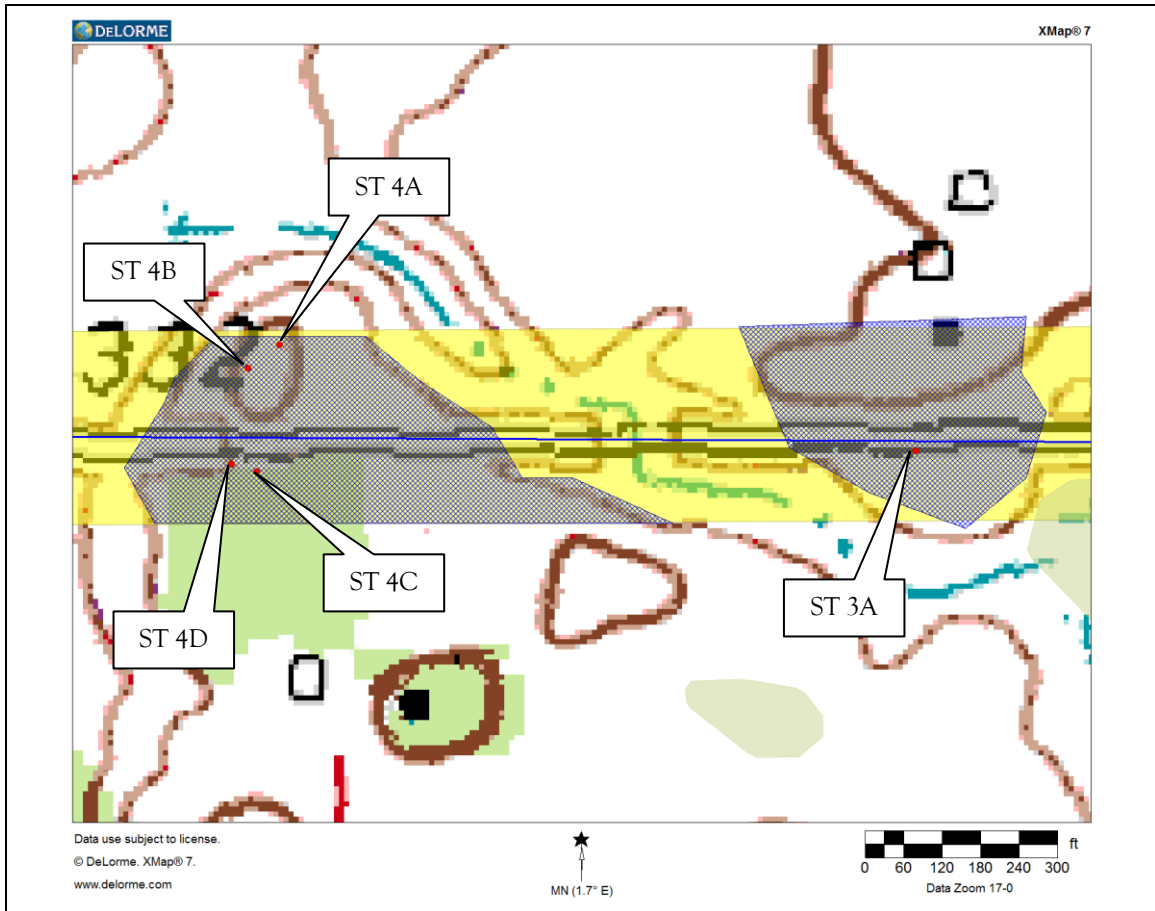

Figure 12. Areas 3 and 4 showing APE (yellow), survey areas (gray), and shovel test locations.

Area 4 was partially grass-covered and partially wooded. Four shovel tests were excavated in Area 4 (see Figure 12). Three of the four shovel tests consisted of 20-30 cm of very dark brown silt over 10-20 cm of brown silt, over compact dark yellowish brown silty clay. The top layer of soil appeared to have been scraped off the fourth shovel test in Area 4, and consisted of approximately 20 cm of brown silt over dark yellowish brown silty clay.

The northeastern corner of Area 5 holds Augustana Cemetery, while the northwestern portion consisted of a cornfield, and the southern portion, an alfalfa field (Figure 13). The earliest grave marker in the cemetery dates to 1911, and the cemetery appears to remain in use. There also appear to be potentially unmarked graves along the eastern end of the cemetery, as evidenced by oblong depressions.



Figure 13. Cemetery in Area 5, looking west.

West of the cemetery was a cornfield (Figure 14). The corn had not been harvested, but offered good to very good (50-70%) surface visibility conditions. This portion of Area 5 was pedestrian surface surveyed in 15 meter transects.



Figure 14. Cornfield in Area 5, looking northwest.

The southern portion of Area 5 consisted of an alfalfa field with poor surface visibility (0-15%) (Figure 15). Three shovel tests were excavated in Area 5 and yielded 40 to 60 cm of compact dark grayish brown silt over yellowish brown clay-silt (Figure 16). No cultural materials or features were identified during the survey of Area 3, 4, or 5.



Figure 15. Alfalfa field in Area 5, looking southwest.

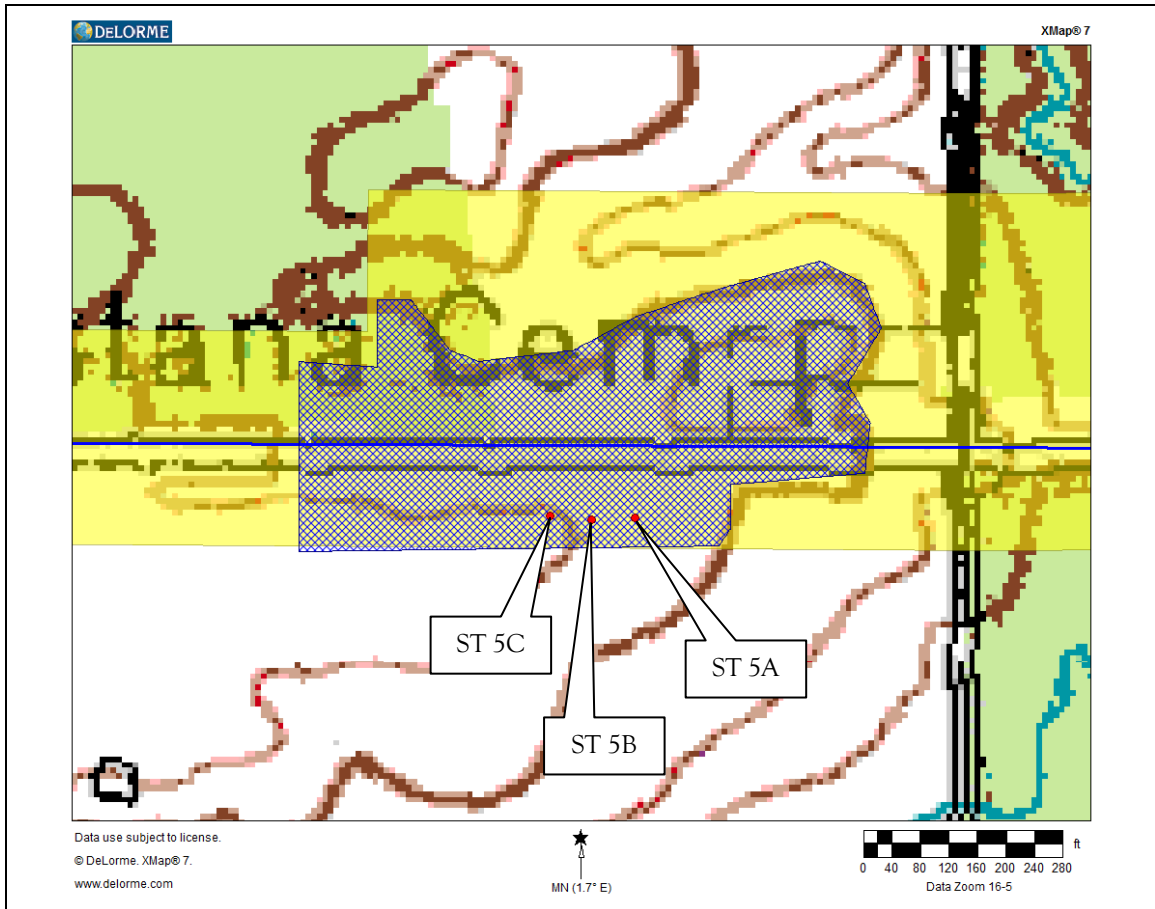

Figure 16. Area 5 showing shovel test locations.

Areas 6 and 7

Areas 6 and 7 are located west of Clearbrook, and overlook a wetland/lake area to the west (see Figure 7; Figure 17). Area 6 was primarily wooded with the far eastern edge consisting of a plowed agricultural field. The eastern portion of Area 6 was pedestrian surface surveyed in 15 meter intervals under excellent surface visibility conditions (>90%) (Figure 18).

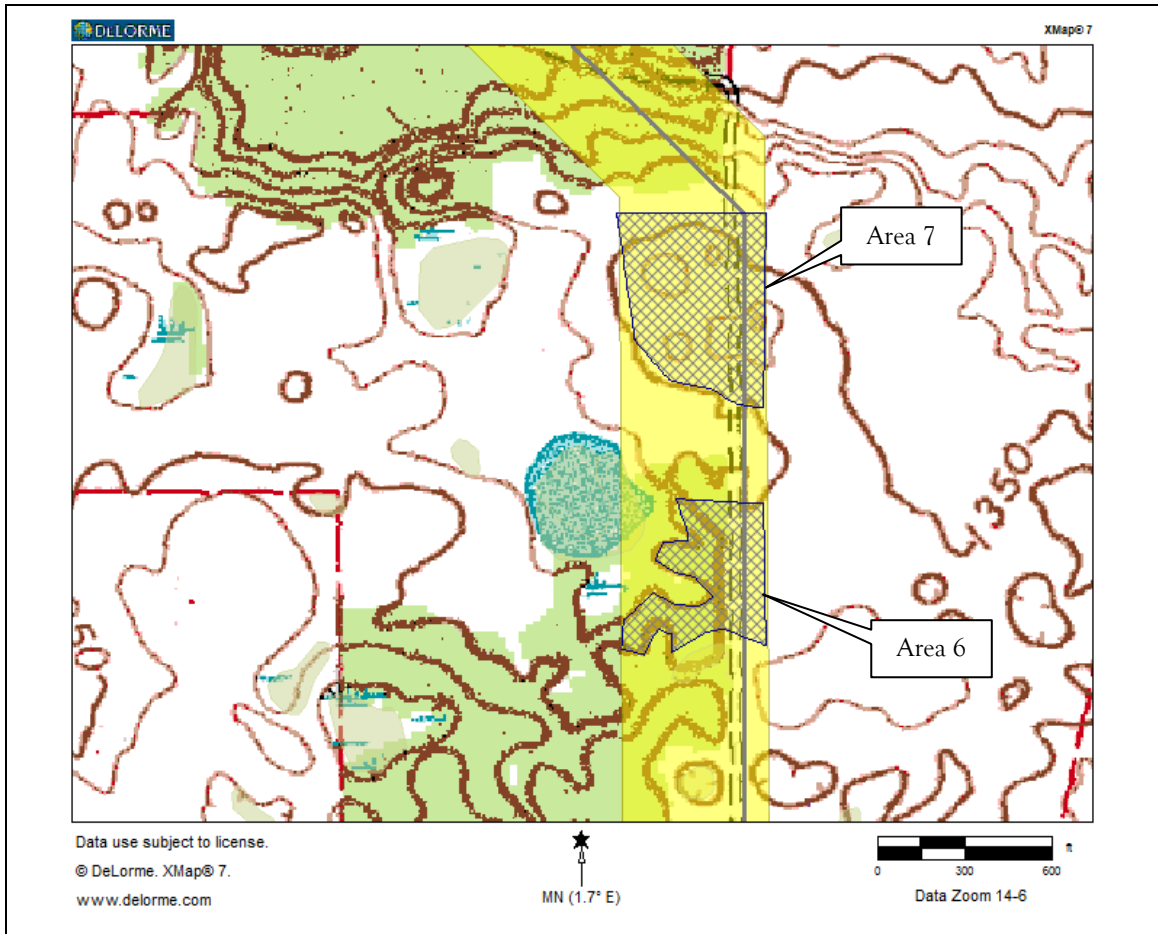

Figure 17. Areas 6 and 7 showing APE (yellow) and survey areas (gray).



Figure 18. Eastern portion of Area 6, looking northeast.

The western portion of Area 6 had poor surface visibility and thus six shovel tests were excavated (Figures 19 and 20). These tests were located along two small ridges adjacent to a wetland, and consisted of approximately 15 to 30 cm of dark brown silt, over approximately 20 cm of light brownish-gray silt, over dark yellowish brown sandy clay.



Figure 19. Area 6, looking west.

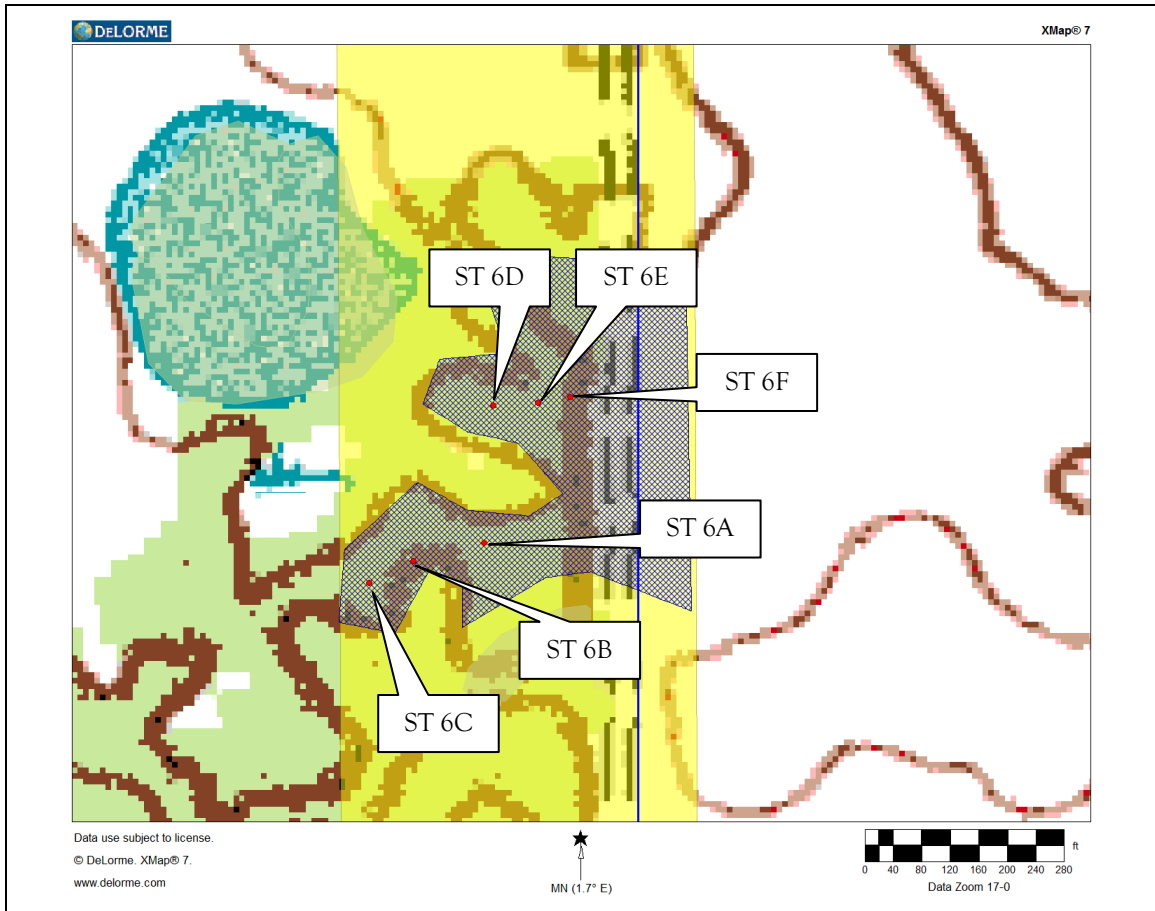

Figure 20. Area 6 showing shovel test locations.

Area 7 consists of a plowed agricultural field (see Figure 18). The area was pedestrian surface surveyed in 15 meter intervals under excellent surface visibility conditions (>90%). No cultural materials or features were identified during the survey of Areas 6 and 7.

Area 8

Area 8 is located on a small terrace overlooking a wetland and lake to the west (see Figure 7; Figures 21, 22, and 23). Area 8 consists of a pasture and had poor surface visibility (0-10%). Five shovel tests were excavated along the ridge (Figure 24). The tests consisted of approximately 20 cm of brown silty sand, over 20 cm of dark yellowish brown sand, over light brown sand. No cultural materials or features were identified during the survey of Area 8.

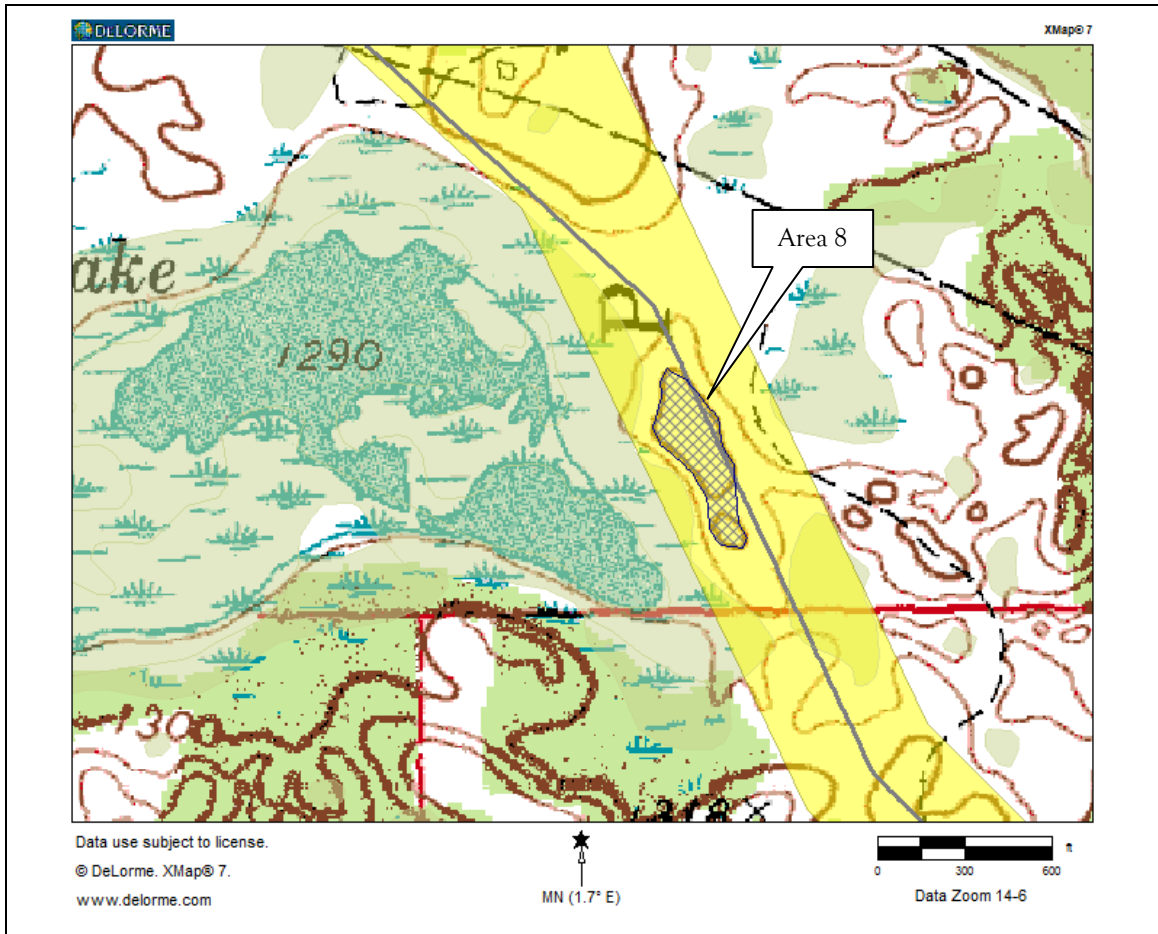

Figure 21. Area 8 showing APE (yellow) and survey areas (gray).



Figure 22. Photograph from Area 8, looking west.



Figure 23. Photograph of Area 8, looking west.

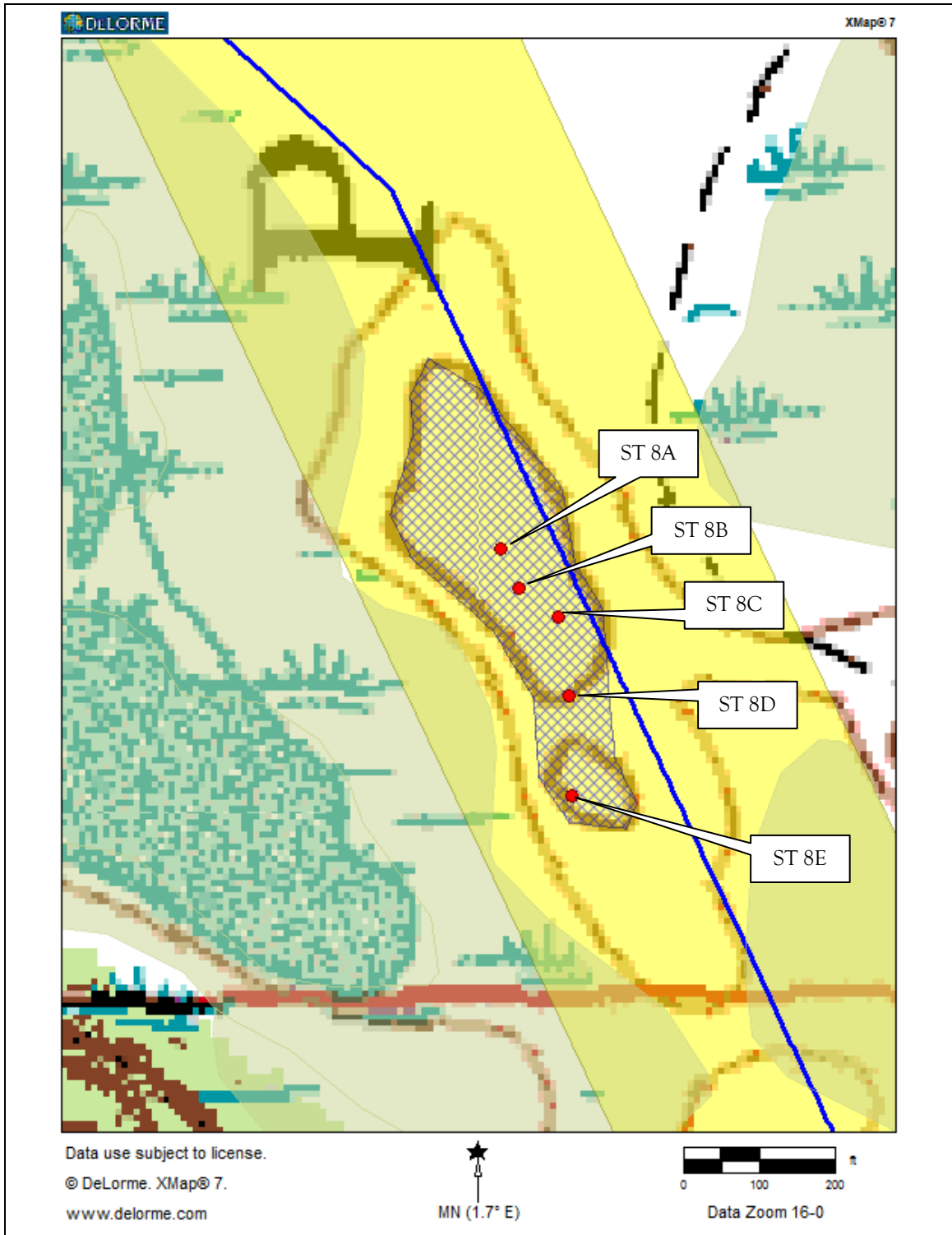

Figure 24. Area 8 showing shovel test locations.

Area 9

Area 9 is located on the far northwestern end of the project area, and is partially within recorded archaeological site 21CE0079 (Figure 25). A portion of the property within Area 9, was also considered outside the scope of this project (depicted in purple on the map) as that parcel is being examined separately.

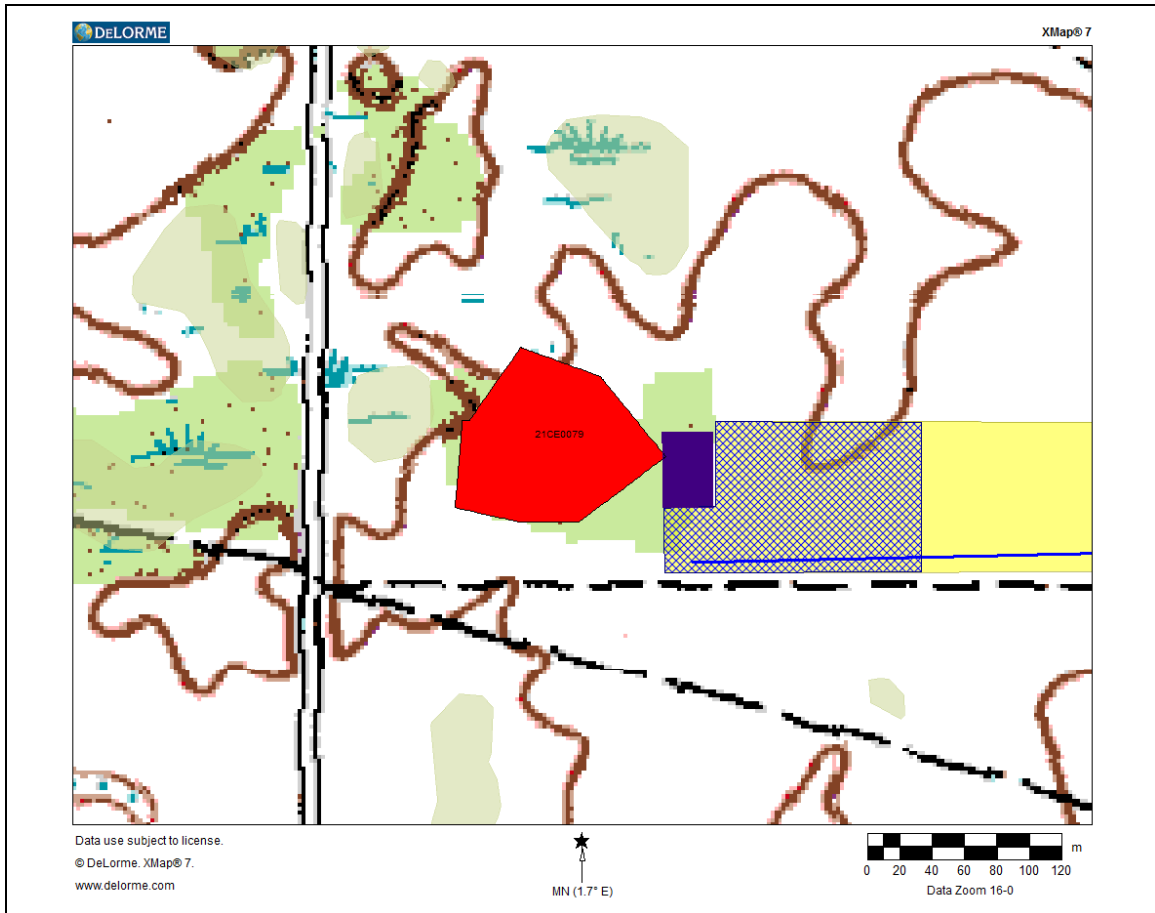

Figure 25. Area 9 showing location of archaeological site 21CE0079.

Site 21CE0079 consists of the remains of an historic farmstead (Figures 26, 27, and 28). The site was recorded in 2013 during which time archaeologists conducted a surface survey and shovel testing. The shovel tests were placed on a 15-meter (50 foot) grid across the site. It does not appear as though any of the features were specifically tested using shovel tests. The 2013 investigations resulted in a recommendation of *not eligible* for the National Register of Historic Places. The State Historic Preservation Office concurred with this recommendation in a letter dated September 4, 2014 (Appendix A).



Figure 26. Surface features at site 21CE0079, facing southeast.



Figure 27. Structural remains at site 21CE0079, facing east.



Figure 28. Structural remains at site 21CE0079, facing southeast.

Examination of this area for the current project, involved an intensive surface survey of the farmstead to determine if historic features relating to the farm might exist within the proposed project APE. Based on the survey of Area 9, the majority of the APE is outside the main historic farmyard, however, the previously recorded site boundaries (2013) excluded a portion of a foundation that appears to have been the barn (an integral part of the farm) (Figure 29). Thus, the site boundaries for 21CE0079 have been modified slightly, and do extend into the APE for the proposed project (Figure 30).



Figure 29. Remains of the possible barn foundation at site 21CE0079, facing southeast.

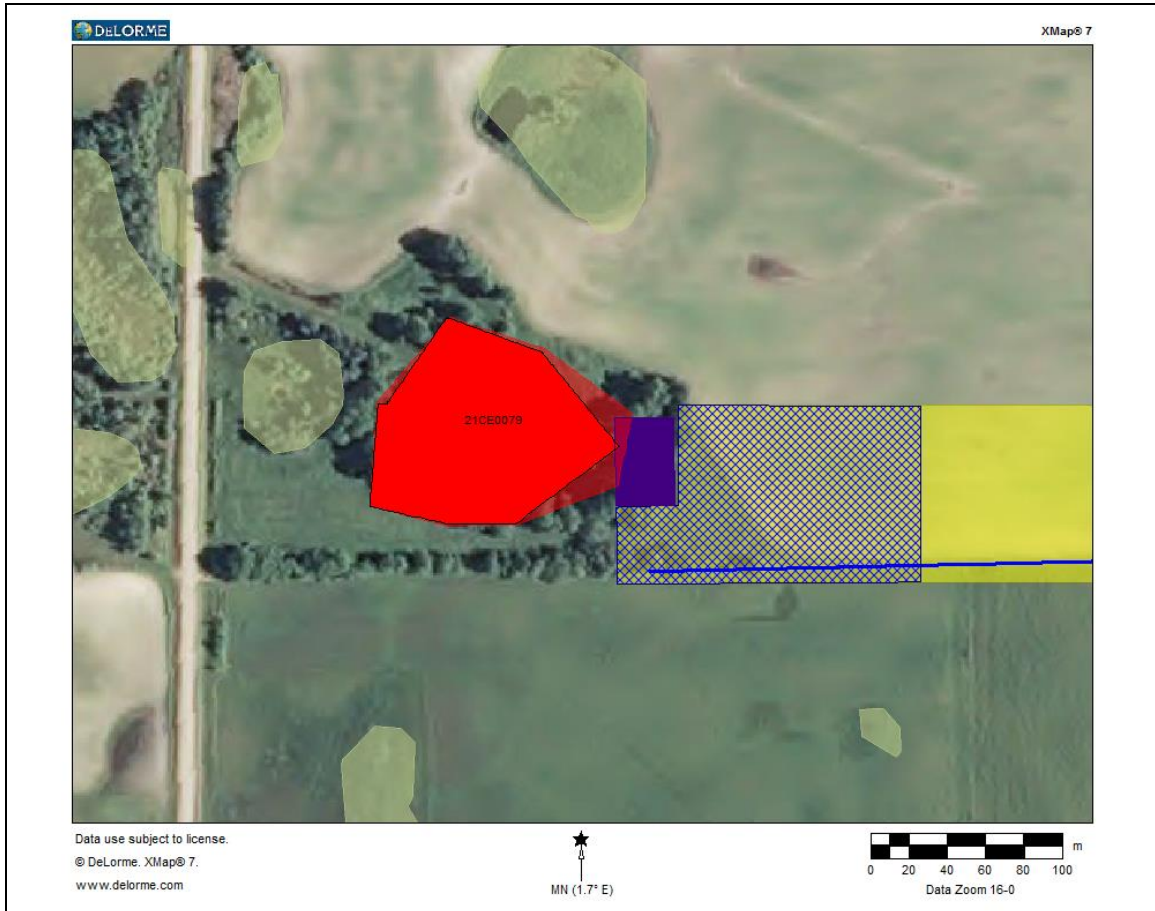

Figure 30. Map showing original (solid red) and revised (blended red) site 21CE0079 boundaries.

Recommendations

The Phase I archaeological survey of nine moderate and high potential areas within the proposed Clearbrook West transmission line APE resulted in the location of no previously unrecorded archaeological sites. Based on the results of the survey, *10,000 Lakes Archaeology* recommends that the project, as proposed, will not affect any archaeological resources. However, two cemeteries are within the APE. *10,000 Lakes Archaeology* recommends that these cemeteries be avoided*. The recorded site located within the proposed project area has been determined not eligible for the National Register of Historic Places, thus no additional work at the site is necessary.

* *Minnesota Statute 307.08, the Private Cemeteries Act, prohibits the intentional disturbance of human burials.*

Bibliography

Anfinson, S.F.

- 1987 *The Prehistory of the Prairie Lake Region of the Northwestern Plains*. Ph.D. dissertation, Department of Anthropology, University of Minnesota, Minneapolis.
- 1990 "Archaeological Regions in Minnesota." In *University of Minnesota Publications in Anthropology, No 4: The Woodland Tradition in the Western Great Lakes: Papers Presented to Elden Johnson*, edited by Guy Gibbon, pp. 135-163, University of Minnesota, Minneapolis.
- 1997 *Southwestern Minnesota Archaeology*. Minnesota Prehistoric Archaeology Series No. 14. Minnesota Historical Society, St. Paul.

Boszhardt, Robert F., James L. Theler, and Thomas F. Kehoe

- 1986 The Early Woodland Stage. In "Introduction to Wisconsin Archaeology: Background for Cultural Resource Planning." *The Wisconsin Archaeologist* 67(3-4):243-262.

General Land Office

- 1891 Survey Map of T149R37W. United States, Dubuque, Iowa Land Office. <http://www.mngeo.state.mn.us/glo/glo.php?township=149&range=37> Accessed November 4, 2014
- 1891 Survey Map of T149R38W. United States, Dubuque, Iowa Land Office. <http://www.mngeo.state.mn.us/glo/glo.php?township=149&range=37> Accessed November 4, 2014

Gibbon, Guy and Scott F. Anfinson

- 2008 *Minnesota Archaeology: The First 13,000 Years*. University of Minnesota Publications in Anthropology, No. 6. University of Minnesota. Accessed online at <http://www.anthropologylabs.umn.edu/new/wlana/first/>

Gronhovd, Amanda

- 2014 *Background Research for Clearbrook West, Clearwater County, Minnesota*. Submitted to Barr Engineering, Minneapolis, Minnesota by 10,000 Lakes Archaeology, South St. Paul, Minnesota.

Johnson, Elden

- 1988 *Prehistoric Peoples of Minnesota*, third edition. Minnesota Historical Society, St. Paul.

Appendix A: Letter from the State Historic Preservation Office

STATE HISTORIC PRESERVATION OFFICE

September 4, 2014

Sara Ploetz
Enbridge
North Dakota Pipeline Company
1409 Hammond Avenue, Second Floor
Superior, WI 54880

RE: Sandpiper Pipeline Project
Cass, Kittson, Red Lake and St. Louis Counties
SHPO Number: 2013-1826

Dear Ms. Ploetz:

Thank you for the opportunity to comment on the above project. Information received in our office on 6 August 2014 has been reviewed pursuant to the responsibilities given to the Minnesota Historical Society by the Minnesota Historic Sites Act and the Minnesota Field Archaeology Act.

As requested in your correspondence dated 5 August 2014, David Mather, SHPO National Register Archaeologist has completed a review of the *2013 Minnesota Archaeological Reconnaissance Studies* (April 2014) report as prepared by Commonwealth Cultural Resources Group and Merjent. His comments and recommendations are summarized below.

General Report Comments

Regarding the Phase I survey, the general approach seems appropriate. However, the report says that the survey protocol is described further in the Appendices, but we could not find this information. It appears from the survey maps that some areas identified as needing survey have not yet been surveyed. Your accompanying correspondence states that routing is still being determined, so we assume additional survey reports will be submitted as the routing is finalized and project review progresses. It will be important to somehow track these additional survey areas in relation to results we are reviewing now.

Specific Site Recommendations, by County:

Polk County

21PL91, 21PL106, 21PL103, 21PL104, 21PL93, 21PL99, 21PL95, 21PL94, 21PL101, CCRG603_CAC-03, 21PL100 – We agree that these sites are not eligible for listing in the National Register of Historic Places (NRHP).

21PL102 – Phase II evaluation was conducted at this site, with a recommendation that it is potentially eligible, pending a geomorphology study. We believe that the geomorphology study will be useful, but that the current data demonstrates that the site is eligible for listing in the NRHP.

21PL96/97 – Phase II evaluation recommends this site(s) as eligible for listing in the NRHP. We agree.

21PL105 – Phase I conducted with recommendation of Phase II evaluation needed. We agree.

21PL92 – Phase I conducted with recommendation of not eligible. We do not believe that the current data is sufficient to support this recommendation. A Phase II evaluation should be conducted to determine eligibility.

21PL98 – Phase II evaluation conducted with recommendation for additional Phase II. We agree that this would be helpful, but that the current data is sufficient to demonstrate it is eligible for listing in the NRHP.

Red Lake County

21RL31 (Note: Red Lake County is **RL** and not **RE**, please correct the references to this site in the report) We agree that this site is not eligible for listing in the NRHP.

Clearwater County

21CE79, 21CE81, 21CE80, 21CE78, CCRG04_MCT_06, 21CE75, 21CE77, 21CE66 – We agree that these sites are not eligible for listing in the NRHP.

21CE76 – Phase I conducted with recommendation of not eligible. We do not believe that the current data is sufficient to support this recommendation. A Phase II evaluation should be conducted to determine eligibility.

Hubbard County

21HB86, 21HB85 – We agree that these sites are not eligible for listing in the NRHP.

21HB81 – Phase I conducted with recommendation of not eligible. We do not believe that the current data is sufficient to support this recommendation. A Phase II evaluation should be conducted to determine eligibility.

21HB79 – Phase I conducted with recommendation of not eligible. We do not believe that the current data is sufficient to support this recommendation. A Phase II evaluation should be conducted to determine eligibility.

21HB82 – Phase I conducted with recommendation that Phase II evaluation is needed. We agree that this is necessary. It is disappointing, however, that there is so little information about the unusual artifacts observed at this site (daub fragments and charred botanical remains). It is surprising that the

artifacts were not collected, or at least photographed in the field. These are presumably fragile materials, and it seems likely that an opportunity has been lost. It's possible that they will still be there when/if the Phase II evaluation is conducted, but it will be a matter of luck if that's the case. This is an example that calls into question the appropriateness of no-collection archaeological surveys.

21HB84 – Phase I conducted with recommendation that Phase II evaluation is needed. We agree that this is necessary.

21HB89 – Phase I conducted with recommendation that Phase II evaluation is needed. We agree that this is necessary.

21HB87 – Phase I conducted with recommendation that the portion of the site within the survey corridor is apparently not eligible (?). We recommend that a Phase II evaluation be conducted at this site to determine eligibility.

21HB80 – Phase I conducted with recommendation that the portion of the site within the survey corridor is apparently not eligible (?). We recommend that a Phase II evaluation be conducted at this site to determine eligibility.

21HB88 – Phase I conducted with recommendation that Phase II evaluation is needed. We agree that this is necessary.

21HB83 – Phase I conducted with recommendation that Phase II evaluation is needed. We agree that this is necessary.

Cass County

CCRG01_CJY_02 – We agree that this site is not eligible for the NRHP.

21CA755 – Phase I conducted with recommendation that the site is not eligible. We agree, but consultation should occur with the Office of the State Archaeologist regarding potential need for burial authentication.

21CA736 – Phase I conducted with recommendation that Phase II evaluation is needed. We agree that this is necessary.

Aitkin County

21AK125, 21AK126 - We agree that these sites are not eligible for listing in the NRHP.

21AK127- Historic cemetery - Consultation with the Office of the State Archaeologist is needed.

Carlton County

21CL47, 21CL43, 21CL46 - We agree that these sites are not eligible for listing in the NRHP.

21CL42 – Phase I conducted with recommendation of not eligible. We do not believe that the current data is sufficient to support this recommendation. A Phase II evaluation should be conducted to determine eligibility.

Please note that this comment letter does not address the requirements of Section 106 of the National Historic Preservation Act of 1966 and 36CFR800, Procedures of the Advisory Council on Historic Preservation for the protection of historic properties.

We look forward to continuing consultation with Enbridge and the Minnesota Public Utilities Commission, and also with the St. Paul District-U.S. Army Corps of Engineers, as this project's environmental review is completed.

Please feel free to contact me at 651-259-3456 or by e-mail at sarah.beimers@mnhs.org if you have any questions or concerns regarding our comments and recommendations.

Sincerely,

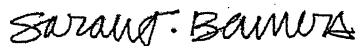

Sarah J. Beimers, Manager
Government Programs and Compliance

cc: Scott Elk, Minnesota Public Utilities Commission
Brad Johnson, USACE, Regulatory Branch
Michael Madsen, Merjent

Appendix F

LGU Notice Letter

July 23, 2014

Clearwater County
213 Main Ave North, Dept 206
Bagley, MN 56621

Attn: Daniel Hecht

**Re: Notice of Proposed Clearbrook - Clearbrook West 115 kilovolt transmission line
Clearwater County, MN
Minnkota Power Cooperative, Inc.**

Gentlemen:

Minnkota Power Cooperative, Inc. ("Minnkota ") is planning to build a new 5.3-mile long, 115 kilovolt (kV) electric transmission project in Leon and Pine Lake Townships of Clearwater County, Minnesota. The proposed Project is needed to serve a single industrial load in the Clearbrook, Minnesota area. Minnkota Power's proposed route is shown on the attached Figure 1. The project is referred to as the Clearbrook - Clearbrook West 115 kV project.

The purpose of this letter is to provide you notice of Minnkota's plan to obtain a route permit from the Minnesota Public Utilities Commission ("MPUC"), and request your comments. The state route permit preempts local land use control per Minnesota Statute § 216E.10. This notice is also required under Minnesota Statute § 216E.03, subd. 3a and 3b to allow each local unit of government within the proposed route area the opportunity to meet with Minnkota to discuss the project prior to filing the state route permit application.

Project Description

As shown in Figure 1, the proposed project will start in Leon Township by tapping an existing 115 kV line via construction of a 1-way line switch and the proposed project will end in Pine Lake Township at a new 115/41.6 kV substation. However, the tap will likely be moved approximately 300 feet in the future to a nearby existing 115 kV substation that is scheduled to have a new 115 kV ring-bus addition. The new 115/41.6 kV distribution substation will have a 20 mega volt ampere (MVA) transformer; a 115 kV disconnect, fusing and circuit breaker; a low side bus, metering equipment, station service, and a disconnect. The 115 kV transmission line will be constructed within a 100-foot wide right-of-way and the new substation will have a 100-foot by 100-foot footprint.

From its starting point in Leon Township, the proposed transmission line extends west, following existing roadway right-of-way along County Road 74 for approximately three miles before turning north to follow existing roadway right-of-way along 149th Avenue for approximately one

mile. Where 149th Avenue terminates, the proposed transmission line would extend northwest along a new corridor for approximately one mile before turning west to connect to the proposed substation. Where the proposed project parallels County Road 74, existing low-voltage distribution lines will be removed and then “under built” on the same structures as the new 115 kV transmission line.

Permitting Requirements

The proposed 115 kV transmission line meets the definition of a High Voltage Transmission Line (“HVTL”) under Minn. Rules Chapter 7850.1000, subp. 9. A route permit is required for the Project, for which Minnkota will apply.

A Certificate of Need (“CON”) is not required for the Project because it is not classified as a large energy facility (“LEF”) under Minn. Stat. §§ 216B.243 and 216B.2421, subd. 2(3). While the Project is a HVTL with a capacity of 100 kV or more, it is not more than 10 miles long and it does not cross a state line. Therefore, Minnkota does not need a CON for this Project.

The route permit proceeding will determine where the proposed facilities will be located. As part of the permitting process, the MPUC considers input from the applicant utility, interested stakeholders, local government units, state and federal agencies, and landowners who may be affected. Minnkota plans to submit an application for a route permit for the Project to the MPUC within the next month. Additional environmental review will occur during the routing process. The routing process will consider environmental, land use, and other potential routing impacts, and provide the opportunity for the public to comment.

Pursuant to Minn. Stat. § 216E.03, subd. 3b, you may request a pre-application consultation meeting regarding the proposed Project within 30 days of receiving this notice. Please review this information and provide any comments, questions, or concerns you may have regarding the proposed project, or notify me if you would like to request a pre-application consultation meeting.

I can be reached by email at jgraves@minnkota.com or by phone at (701) 795-4221. I look forward to hearing from you.

Sincerely,

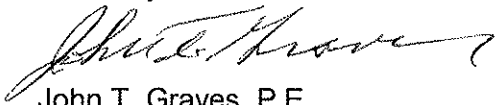

John T. Graves, P.E.
Environmental Manager
Minnkota Power Cooperative

Enclosure: Figure 1

Cc: Jay Bushy, Minnkota
Louise Segroves, Barr Engineering

July 23, 2014

Pine Lake Township
15614 500th St.
Gonvick, MN 56644

Attn: Paul Buer

**Re: Notice of Proposed Clearbrook - Clearbrook West 115 kilovolt transmission line
Clearwater County, MN
Minnkota Power Cooperative, Inc.**

Gentlemen:

Minnkota Power Cooperative, Inc. ("Minnkota ") is planning to build a new 5.3-mile long, 115 kilovolt (kV) electric transmission project in Leon and Pine Lake Townships of Clearwater County, Minnesota. The proposed Project is needed to serve a single industrial load in the Clearbrook, Minnesota area. Minnkota Power's proposed route is shown on the attached Figure 1. The project is referred to as the Clearbrook - Clearbrook West 115 kV project.

The purpose of this letter is to provide you notice of Minnkota's plan to obtain a route permit from the Minnesota Public Utilities Commission ("MPUC"), and request your comments. The state route permit preempts local land use control per Minnesota Statute § 216E.10. This notice is also required under Minnesota Statute § 216E.03, subd. 3a and 3b to allow each local unit of government within the proposed route area the opportunity to meet with Minnkota to discuss the project prior to filing the state route permit application.

Project Description

As shown in Figure 1, the proposed project will start in Leon Township by tapping an existing 115 kV line via construction of a 1-way line switch and the proposed project will end in Pine Lake Township at a new 115/41.6 kV substation. However, the tap will likely be moved approximately 300 feet in the future to a nearby existing 115 kV substation that is scheduled to have a new 115 kV ring-bus addition. The new 115/41.6 kV distribution substation will have a 20 mega volt ampere (MVA) transformer; a 115 kV disconnect, fusing and circuit breaker; a low side bus, metering equipment, station service, and a disconnect. The 115 kV transmission line will be constructed within a 100-foot wide right-of-way and the new substation will have a 100-foot by 100-foot footprint.

From its starting point in Leon Township, the proposed transmission line extends west, following existing roadway right-of-way along County Road 74 for approximately three miles before turning north to follow existing roadway right-of-way along 149th Avenue for approximately one

mile. Where 149th Avenue terminates, the proposed transmission line would extend northwest along a new corridor for approximately one mile before turning west to connect to the proposed substation. Where the proposed project parallels County Road 74, existing low-voltage distribution lines will be removed and then “under built” on the same structures as the new 115 kV transmission line.

Permitting Requirements

The proposed 115 kV transmission line meets the definition of a High Voltage Transmission Line (“HVTL”) under Minn. Rules Chapter 7850.1000, subp. 9. A route permit is required for the Project, for which Minnkota will apply.

A Certificate of Need (“CON”) is not required for the Project because it is not classified as a large energy facility (“LEF”) under Minn. Stat. §§ 216B.243 and 216B.2421, subd. 2(3). While the Project is a HVTL with a capacity of 100 kV or more, it is not more than 10 miles long and it does not cross a state line. Therefore, Minnkota does not need a CON for this Project.

The route permit proceeding will determine where the proposed facilities will be located. As part of the permitting process, the MPUC considers input from the applicant utility, interested stakeholders, local government units, state and federal agencies, and landowners who may be affected. Minnkota plans to submit an application for a route permit for the Project to the MPUC within the next month. Additional environmental review will occur during the routing process. The routing process will consider environmental, land use, and other potential routing impacts, and provide the opportunity for the public to comment.

Pursuant to Minn. Stat. § 216E.03, subd. 3b, you may request a pre-application consultation meeting regarding the proposed Project within 30 days of receiving this notice. Please review this information and provide any comments, questions, or concerns you may have regarding the proposed project, or notify me if you would like to request a pre-application consultation meeting.

I can be reached by email at jgraves@minnkota.com or by phone at (701) 795-4221. I look forward to hearing from you.

Sincerely,

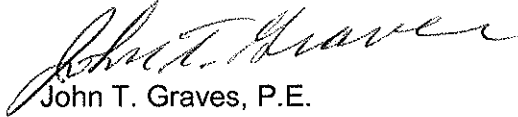

John T. Graves, P.E.
Environmental Manager
Minnkota Power Cooperative

Enclosure: Figure 1

Cc: Jay Bushy, Minnkota
Louise Segroves, Barr Engineering

July 23, 2014

Pine Lake Township
47807 E. Pine Lake Rd.
Gonvick, MN 56644

Attn: Richard Aos

**Re: Notice of Proposed Clearbrook - Clearbrook West 115 kilovolt transmission line
Clearwater County, MN
Minnkota Power Cooperative, Inc.**

Gentlemen:

Minnkota Power Cooperative, Inc. ("Minnkota ") is planning to build a new 5.3-mile long, 115 kilovolt (kV) electric transmission project in Leon and Pine Lake Townships of Clearwater County, Minnesota. The proposed Project is needed to serve a single industrial load in the Clearbrook, Minnesota area. Minnkota Power's proposed route is shown on the attached Figure 1. The project is referred to as the Clearbrook - Clearbrook West 115 kV project.

The purpose of this letter is to provide you notice of Minnkota's plan to obtain a route permit from the Minnesota Public Utilities Commission ("MPUC"), and request your comments. The state route permit preempts local land use control per Minnesota Statute § 216E.10. This notice is also required under Minnesota Statute § 216E.03, subd. 3a and 3b to allow each local unit of government within the proposed route area the opportunity to meet with Minnkota to discuss the project prior to filing the state route permit application.

Project Description

As shown in Figure 1, the proposed project will start in Leon Township by tapping an existing 115 kV line via construction of a 1-way line switch and the proposed project will end in Pine Lake Township at a new 115/41.6 kV substation. However, the tap will likely be moved approximately 300 feet in the future to a nearby existing 115 kV substation that is scheduled to have a new 115 kV ring-bus addition. The new 115/4.16 kV distribution substation will have a 20 mega volt ampere (MVA) transformer; a 115 kV disconnect, fusing and circuit breaker; a low side bus, metering equipment, station service, and a disconnect. The 115 kV transmission line will be constructed within a 100-foot wide right-of-way and the new substation will have a 100-foot by 100-foot footprint.

From its starting point in Leon Township, the proposed transmission line extends west, following existing roadway right-of-way along County Road 74 for approximately three miles before turning north to follow existing roadway right-of-way along 149th Avenue for approximately one

mile. Where 149th Avenue terminates, the proposed transmission line would extend northwest along a new corridor for approximately one mile before turning west to connect to the proposed substation. Where the proposed project parallels County Road 74, existing low-voltage distribution lines will be removed and then “under built” on the same structures as the new 115 kV transmission line.

Permitting Requirements

The proposed 115 kV transmission line meets the definition of a High Voltage Transmission Line (“HVTL”) under Minn. Rules Chapter 7850.1000, subp. 9. A route permit is required for the Project, for which Minnkota will apply.

A Certificate of Need (“CON”) is not required for the Project because it is not classified as a large energy facility (“LEF”) under Minn. Stat. §§ 216B.243 and 216B.2421, subd. 2(3). While the Project is a HVTL with a capacity of 100 kV or more, it is not more than 10 miles long and it does not cross a state line. Therefore, Minnkota does not need a CON for this Project.

The route permit proceeding will determine where the proposed facilities will be located. As part of the permitting process, the MPUC considers input from the applicant utility, interested stakeholders, local government units, state and federal agencies, and landowners who may be affected. Minnkota plans to submit an application for a route permit for the Project to the MPUC within the next month. Additional environmental review will occur during the routing process. The routing process will consider environmental, land use, and other potential routing impacts, and provide the opportunity for the public to comment.

Pursuant to Minn. Stat. § 216E.03, subd. 3b, you may request a pre-application consultation meeting regarding the proposed Project within 30 days of receiving this notice. Please review this information and provide any comments, questions, or concerns you may have regarding the proposed project, or notify me if you would like to request a pre-application consultation meeting.

I can be reached by email at jgraves@minnkota.com or by phone at (701) 795-4221. I look forward to hearing from you.

Sincerely,

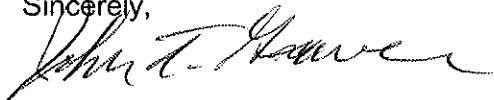

John T. Graves, P.E.
Environmental Manager
Minnkota Power Cooperative

Enclosure: Figure 1

Cc: Jay Bushy, Minnkota
Louise Segroves, Barr Engineering

July 23, 2014

Leon Township
19837 500th St.
Clearbrook, MN 56634

Attn: Lori Larson

**Re: Notice of Proposed Clearbrook - Clearbrook West 115 kilovolt transmission line
Clearwater County, MN
Minnkota Power Cooperative, Inc.**

Gentlemen:

Minnkota Power Cooperative, Inc. ("Minnkota ") is planning to build a new 5.3-mile long, 115 kilovolt (kV) electric transmission project in Leon and Pine Lake Townships of Clearwater County, Minnesota. The proposed Project is needed to serve a single industrial load in the Clearbrook, Minnesota area. Minnkota Power's proposed route is shown on the attached Figure 1. The project is referred to as the Clearbrook - Clearbrook West 115 kV project.

The purpose of this letter is to provide you notice of Minnkota's plan to obtain a route permit from the Minnesota Public Utilities Commission ("MPUC"), and request your comments. The state route permit preempts local land use control per Minnesota Statute § 216E.10. This notice is also required under Minnesota Statute § 216E.03, subd. 3a and 3b to allow each local unit of government within the proposed route area the opportunity to meet with Minnkota to discuss the project prior to filing the state route permit application.

Project Description

As shown in Figure 1, the proposed project will start in Leon Township by tapping an existing 115 kV line via construction of a 1-way line switch and the proposed project will end in Pine Lake Township at a new 115/41.6 kV substation. However, the tap will likely be moved approximately 300 feet in the future to a nearby existing 115 kV substation that is scheduled to have a new 115 kV ring-bus addition. The new 115/4.16 kV distribution substation will have a 20 mega volt ampere (MVA) transformer; a 115 kV disconnect, fusing and circuit breaker; a low side bus, metering equipment, station service, and a disconnect. The 115 kV transmission line will be constructed within a 100-foot wide right-of-way and the new substation will have a 100-foot by 100-foot footprint.

From its starting point in Leon Township, the proposed transmission line extends west, following existing roadway right-of-way along County Road 74 for approximately three miles before turning north to follow existing roadway right-of-way along 149th Avenue for approximately one

mile. Where 149th Avenue terminates, the proposed transmission line would extend northwest along a new corridor for approximately one mile before turning west to connect to the proposed substation. Where the proposed project parallels County Road 74, existing low-voltage distribution lines will be removed and then “under built” on the same structures as the new 115 kV transmission line.

Permitting Requirements

The proposed 115 kV transmission line meets the definition of a High Voltage Transmission Line (“HVTL”) under Minn. Rules Chapter 7850.1000, subp. 9. A route permit is required for the Project, for which Minnkota will apply.

A Certificate of Need (“CON”) is not required for the Project because it is not classified as a large energy facility (“LEF”) under Minn. Stat. §§ 216B.243 and 216B.2421, subd. 2(3). While the Project is a HVTL with a capacity of 100 kV or more, it is not more than 10 miles long and it does not cross a state line. Therefore, Minnkota does not need a CON for this Project.

The route permit proceeding will determine where the proposed facilities will be located. As part of the permitting process, the MPUC considers input from the applicant utility, interested stakeholders, local government units, state and federal agencies, and landowners who may be affected. Minnkota plans to submit an application for a route permit for the Project to the MPUC within the next month. Additional environmental review will occur during the routing process. The routing process will consider environmental, land use, and other potential routing impacts, and provide the opportunity for the public to comment.

Pursuant to Minn. Stat. § 216E.03, subd. 3b, you may request a pre-application consultation meeting regarding the proposed Project within 30 days of receiving this notice. Please review this information and provide any comments, questions, or concerns you may have regarding the proposed project, or notify me if you would like to request a pre-application consultation meeting.

I can be reached by email at jgraves@minnkota.com or by phone at (701) 795-4221. I look forward to hearing from you.

Sincerely,



John T. Graves, P.E.
Environmental Manager
Minnkota Power Cooperative

Enclosure: Figure 1

Cc: Jay Bushy, Minnkota
Louise Segroves, Barr Engineering

July 23, 2014

Leon Township
49209 189th Ave.
Clearbrook, MN 56634

Attn: James Aakre

**Re: Notice of Proposed Clearbrook - Clearbrook West 115 kilovolt transmission line
Clearwater County, MN
Minnkota Power Cooperative, Inc.**

Gentlemen:

Minnkota Power Cooperative, Inc. ("Minnkota ") is planning to build a new 5.3-mile long, 115 kilovolt (kV) electric transmission project in Leon and Pine Lake Townships of Clearwater County, Minnesota. The proposed Project is needed to serve a single industrial load in the Clearbrook, Minnesota area. Minnkota Power's proposed route is shown on the attached Figure 1. The project is referred to as the Clearbrook - Clearbrook West 115 kV project.

The purpose of this letter is to provide you notice of Minnkota's plan to obtain a route permit from the Minnesota Public Utilities Commission ("MPUC"), and request your comments. The state route permit preempts local land use control per Minnesota Statute § 216E.10. This notice is also required under Minnesota Statute § 216E.03, subd. 3a and 3b to allow each local unit of government within the proposed route area the opportunity to meet with Minnkota to discuss the project prior to filing the state route permit application.

Project Description

As shown in Figure 1, the proposed project will start in Leon Township by tapping an existing 115 kV line via construction of a 1-way line switch and the proposed project will end in Pine Lake Township at a new 115/41.6 kV substation. However, the tap will likely be moved approximately 300 feet in the future to a nearby existing 115 kV substation that is scheduled to have a new 115 kV ring-bus addition. The new 115/4.16 kV distribution substation will have a 20 mega volt ampere (MVA) transformer; a 115 kV disconnect, fusing and circuit breaker; a low side bus, metering equipment, station service, and a disconnect. The 115 kV transmission line will be constructed within a 100-foot wide right-of-way and the new substation will have a 100-foot by 100-foot footprint.

From its starting point in Leon Township, the proposed transmission line extends west, following existing roadway right-of-way along County Road 74 for approximately three miles before turning north to follow existing roadway right-of-way along 149th Avenue for approximately one

mile. Where 149th Avenue terminates, the proposed transmission line would extend northwest along a new corridor for approximately one mile before turning west to connect to the proposed substation. Where the proposed project parallels County Road 74, existing low-voltage distribution lines will be removed and then “under built” on the same structures as the new 115 kV transmission line.

Permitting Requirements

The proposed 115 kV transmission line meets the definition of a High Voltage Transmission Line (“HVTL”) under Minn. Rules Chapter 7850.1000, subp. 9. A route permit is required for the Project, for which Minnkota will apply.

A Certificate of Need (“CON”) is not required for the Project because it is not classified as a large energy facility (“LEF”) under Minn. Stat. §§ 216B.243 and 216B.2421, subd. 2(3). While the Project is a HVTL with a capacity of 100 kV or more, it is not more than 10 miles long and it does not cross a state line. Therefore, Minnkota does not need a CON for this Project.

The route permit proceeding will determine where the proposed facilities will be located. As part of the permitting process, the MPUC considers input from the applicant utility, interested stakeholders, local government units, state and federal agencies, and landowners who may be affected. Minnkota plans to submit an application for a route permit for the Project to the MPUC within the next month. Additional environmental review will occur during the routing process. The routing process will consider environmental, land use, and other potential routing impacts, and provide the opportunity for the public to comment.

Pursuant to Minn. Stat. § 216E.03, subd. 3b, you may request a pre-application consultation meeting regarding the proposed Project within 30 days of receiving this notice. Please review this information and provide any comments, questions, or concerns you may have regarding the proposed project, or notify me if you would like to request a pre-application consultation meeting.

I can be reached by email at jgraves@minnkota.com or by phone at (701) 795-4221. I look forward to hearing from you.

Sincerely,



John T. Graves, P.E.
Environmental Manager
Minnkota Power Cooperative

Enclosure: Figure 1

Cc: Jay Bushy, Minnkota
Louise Segroves, Barr Engineering

July 23, 2014

City of Gonvick
140 Cedar St.
Gonvick, MN 56644

Attn: Dan Sundquist

**Re: Notice of Proposed Clearbrook - Clearbrook West 115 kilovolt transmission line
Clearwater County, MN
Minnkota Power Cooperative, Inc.**

Gentlemen:

Minnkota Power Cooperative, Inc. ("Minnkota ") is planning to build a new 5.3-mile long, 115 kilovolt (kV) electric transmission project in Leon and Pine Lake Townships of Clearwater County, Minnesota. The proposed Project is needed to serve a single industrial load in the Clearbrook, Minnesota area. Minnkota Power's proposed route is shown on the attached Figure 1. The project is referred to as the Clearbrook - Clearbrook West 115 kV project.

The purpose of this letter is to provide you notice of Minnkota's plan to obtain a route permit from the Minnesota Public Utilities Commission ("MPUC"), and request your comments. The state route permit preempts local land use control per Minnesota Statute § 216E.10. This notice is also required under Minnesota Statute § 216E.03, subd. 3a and 3b to allow each local unit of government within the proposed route area the opportunity to meet with Minnkota to discuss the project prior to filing the state route permit application.

Project Description

As shown in Figure 1, the proposed project will start in Leon Township by tapping an existing 115 kV line via construction of a 1-way line switch and the proposed project will end in Pine Lake Township at a new 115/41.6 kV substation. However, the tap will likely be moved approximately 300 feet in the future to a nearby existing 115 kV substation that is scheduled to have a new 115 kV ring-bus addition. The new 115/4.16 kV distribution substation will have a 20 mega volt ampere (MVA) transformer; a 115 kV disconnect, fusing and circuit breaker; a low side bus, metering equipment, station service, and a disconnect. The 115 kV transmission line will be constructed within a 100-foot wide right-of-way and the new substation will have a 100-foot by 100-foot footprint.

From its starting point in Leon Township, the proposed transmission line extends west, following existing roadway right-of-way along County Road 74 for approximately three miles before turning north to follow existing roadway right-of-way along 149th Avenue for approximately one

mile. Where 149th Avenue terminates, the proposed transmission line would extend northwest along a new corridor for approximately one mile before turning west to connect to the proposed substation. Where the proposed project parallels County Road 74, existing low-voltage distribution lines will be removed and then “under built” on the same structures as the new 115 kV transmission line.

Permitting Requirements

The proposed 115 kV transmission line meets the definition of a High Voltage Transmission Line (“HVTL”) under Minn. Rules Chapter 7850.1000, subp. 9. A route permit is required for the Project, for which Minnkota will apply.

A Certificate of Need (“CON”) is not required for the Project because it is not classified as a large energy facility (“LEF”) under Minn. Stat. §§ 216B.243 and 216B.2421, subd. 2(3). While the Project is a HVTL with a capacity of 100 kV or more, it is not more than 10 miles long and it does not cross a state line. Therefore, Minnkota does not need a CON for this Project.

The route permit proceeding will determine where the proposed facilities will be located. As part of the permitting process, the MPUC considers input from the applicant utility, interested stakeholders, local government units, state and federal agencies, and landowners who may be affected. Minnkota plans to submit an application for a route permit for the Project to the MPUC within the next month. Additional environmental review will occur during the routing process. The routing process will consider environmental, land use, and other potential routing impacts, and provide the opportunity for the public to comment.

Pursuant to Minn. Stat. § 216E.03, subd. 3b, you may request a pre-application consultation meeting regarding the proposed Project within 30 days of receiving this notice. Please review this information and provide any comments, questions, or concerns you may have regarding the proposed project, or notify me if you would like to request a pre-application consultation meeting.

I can be reached by email at jgraves@minnkota.com or by phone at (701) 795-4221. I look forward to hearing from you.

Sincerely,

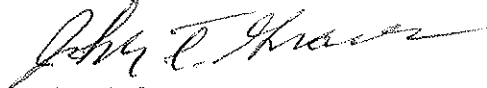

John T. Graves, P.E.
Environmental Manager
Minnkota Power Cooperative

Enclosure: Figure 1

Cc: Jay Bushy, Minnkota
Louise Segroves, Barr Engineering

July 23, 2014

City of Clearbrook
PO Box 62
Clearbrook, MN 56634

Attn: George Postier

**Re: Notice of Proposed Clearbrook - Clearbrook West 115 kilovolt transmission line
Clearwater County, MN
Minnkota Power Cooperative, Inc.**

Gentlemen:

Minnkota Power Cooperative, Inc. ("Minnkota ") is planning to build a new 5.3-mile long, 115 kilovolt (kV) electric transmission project in Leon and Pine Lake Townships of Clearwater County, Minnesota. The proposed Project is needed to serve a single industrial load in the Clearbrook, Minnesota area. Minnkota Power's proposed route is shown on the attached Figure 1. The project is referred to as the Clearbrook - Clearbrook West 115 kV project.

The purpose of this letter is to provide you notice of Minnkota's plan to obtain a route permit from the Minnesota Public Utilities Commission ("MPUC"), and request your comments. The state route permit preempts local land use control per Minnesota Statute § 216E.10. This notice is also required under Minnesota Statute § 216E.03, subd. 3a and 3b to allow each local unit of government within the proposed route area the opportunity to meet with Minnkota to discuss the project prior to filing the state route permit application.

Project Description

As shown in Figure 1, the proposed project will start in Leon Township by tapping an existing 115 kV line via construction of a 1-way line switch and the proposed project will end in Pine Lake Township at a new 115/41.6 kV substation. However, the tap will likely be moved approximately 300 feet in the future to a nearby existing 115 kV substation that is scheduled to have a new 115 kV ring-bus addition. The new 115/4.16 kV distribution substation will have a 20 mega volt ampere (MVA) transformer; a 115 kV disconnect, fusing and circuit breaker; a low side bus, metering equipment, station service, and a disconnect. The 115 kV transmission line will be constructed within a 100-foot wide right-of-way and the new substation will have a 100-foot by 100-foot footprint.

From its starting point in Leon Township, the proposed transmission line extends west, following existing roadway right-of-way along County Road 74 for approximately three miles before turning north to follow existing roadway right-of-way along 149th Avenue for approximately one

mile. Where 149th Avenue terminates, the proposed transmission line would extend northwest along a new corridor for approximately one mile before turning west to connect to the proposed substation. Where the proposed project parallels County Road 74, existing low-voltage distribution lines will be removed and then "under built" on the same structures as the new 115 kV transmission line.

Permitting Requirements

The proposed 115 kV transmission line meets the definition of a High Voltage Transmission Line ("HVTL") under Minn. Rules Chapter 7850.1000, subp. 9. A route permit is required for the Project, for which Minnkota will apply.

A Certificate of Need ("CON") is not required for the Project because it is not classified as a large energy facility ("LEF") under Minn. Stat. §§ 216B.243 and 216B.2421, subd. 2(3). While the Project is a HVTL with a capacity of 100 kV or more, it is not more than 10 miles long and it does not cross a state line. Therefore, Minnkota does not need a CON for this Project.

The route permit proceeding will determine where the proposed facilities will be located. As part of the permitting process, the MPUC considers input from the applicant utility, interested stakeholders, local government units, state and federal agencies, and landowners who may be affected. Minnkota plans to submit an application for a route permit for the Project to the MPUC within the next month. Additional environmental review will occur during the routing process. The routing process will consider environmental, land use, and other potential routing impacts, and provide the opportunity for the public to comment.

Pursuant to Minn. Stat. § 216E.03, subd. 3b, you may request a pre-application consultation meeting regarding the proposed Project within 30 days of receiving this notice. Please review this information and provide any comments, questions, or concerns you may have regarding the proposed project, or notify me if you would like to request a pre-application consultation meeting.

I can be reached by email at jgraves@minnkota.com or by phone at (701) 795-4221. I look forward to hearing from you.

Sincerely,

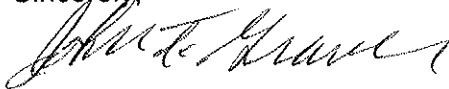

John T. Graves, P.E.
Environmental Manager
Minnkota Power Cooperative

Enclosure: Figure 1

Cc: Jay Bushy, Minnkota
Louise Segroves, Barr Engineering

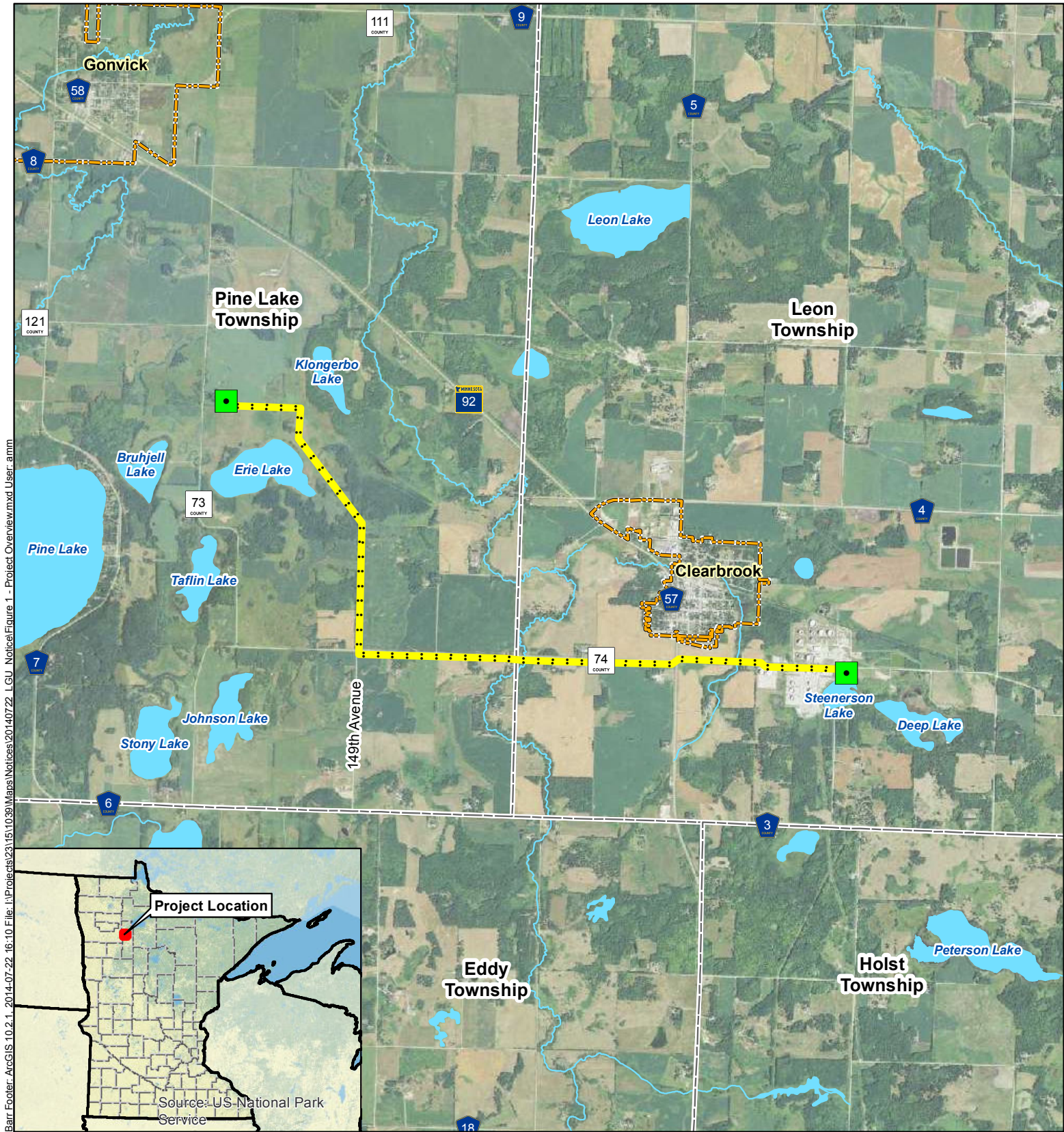

Barr Footer: ArcGIS 10.2.1, 2014-07-22 16:10 File: I:\Projects\23151\1039\Maps\notices\20140722_LGU_Notice\Figure 1 - Project Overview.mxd User: ammm

Image Source: 2013 Farm Service Agency

- Approximate Substation Location
- Proposed Clearbrook 115 kV
- Municipal Boundary
- Township Boundary
- PWI Watercourse
- PWI Basin

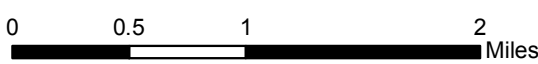

Figure 1

PROJECT OVERVIEW
 Proposed Clearbrook West
 115 kV HVTL Project
 Minnkota Power
 Clearwater County, MN

Appendix G

Agency Correspondence

AFFIDAVIT OF MAILING

STATE OF MINNESOTA)
) ss.
COUNTY OF HENNEPIN)

Lisa Ungar of the city of Minneapolis, county of Hennepin, state of Minnesota, certifies that on the 20th day of October, 2014, she mailed copies of the attached document to the attached list of persons by depositing a true and correct copy thereof, properly enveloped with postage paid in the United States Mail at Minneapolis, Minnesota.



Lisa Ungar

Subscribed and sworn to before me this
20th day of October, 2014.



Notary Public



October 20, 2014

Jamie Schrenzel
Principal Planner, Environmental Review Unit Principal Planner, Environmental Review Unit
MN DNR
500 Lafayette Road Box 25
St. Paul, MN 55155

Re: Notice of Proposed Clearbrook - Clearbrook West 115 kilovolt transmission line
Clearwater County, MN
Minnkota Power Cooperative, Inc.

Dear Ms. Jamie Schrenzel:

Minnkota Power Cooperative, Inc. ("Minnkota Power") is planning to build a new 5.3-mile long, 115 kilovolt (kV) electric transmission line and a new 115/4.16 kV substation. The proposed project will start in Leon Township by tapping an existing 115 kV line via construction of a 1-way switch and the proposed project will end in Pine Lake Township at the new 115/4.16 kV substation (Figure 1). The proposed project is needed to serve a single industrial load in the Clearbrook, Minnesota area.

The purpose of this letter is to provide you notice of Minnkota Power's plan to obtain a route permit from the Minnesota Public Utilities Commission ("MPUC") for the proposed project. This letter is also intended as a request for any comments you may have regarding the project or information that your agency would like to provide relative to the project area. Minnkota Power plans to submit a Route Permit Application (RPA) to the MPUC before the end of this month. Comments or information that you are able to provide in response to this letter will be used in the preparation of the RPA as well as in the preparation of an Environmental Report for the Rural Utilities Service.

Project Description

The proposed Project involves building 5.3 miles of new 115 kV HVTL. The proposed Project will mainly use single pole, wood or steel horizontal post or horizontal brace post structures. However, two-pole or three-pole structures may be utilized where a long span is needed to cross a wetland. One three-pole structure will be utilized where the line crosses a wetland and immediately makes a turn. As shown in Figure 1, the proposed Project will start in Leon Township by tapping an existing 115 kV line via construction of a 1-way line switch and the proposed Project will end in Pine Lake Township at the proposed 115/4.16 kV Substation Location.

From its starting point in Leon Township, the proposed HVTL extends west, following existing roadway ROW and an existing distribution line along County Road 74 for approximately three miles before turning north to follow existing roadway ROW along 149th Avenue for approximately one mile. Where 149th Avenue terminates, the proposed HVTL would extend northwest along a new right-of-way for approximately one mile before turning west to connect to the proposed Substation Location. Where the proposed Project parallels County Road 74, existing low-voltage distribution lines will be removed and

buried by Clearwater-Polk Electric Cooperative. No structures will be located in wetlands. Additionally, all spans that cross wetlands will have bird flight diverters installed.

Permitting Requirements

The proposed 115 kV transmission line meets the definition of a High Voltage Transmission Line ("HVTL") under Minn. Rules Chapter 7850.1000, subp. 9. A route permit is required for the Project, for which Minnkota Power will apply.

A Certificate of Need ("CON") is not required for the Project because it is not classified as a large energy facility ("LEF") under Minn. Stat. §§ 216B.243 and 216B.2421, subd. 2(3). While the Project is a HVTL with a capacity of 100 kV or more, it is not more than 10 miles long and it does not cross a state line. Therefore, Minnkota Power does not need a CON for this Project.

The route permit proceeding will determine where the proposed facilities will be located. As part of the permitting process, the MPUC considers input from the applicant utility, interested stakeholders, local government units, state and federal agencies, and landowners who may be affected. Minnkota plans to submit an application for a route permit for the Project to the MPUC within one month. Additional environmental review will occur during the routing process. The routing process will consider environmental, land use, and other potential routing impacts, and provide the opportunity for the public to comment.

As Minnkota will be seeking funding for this project from the Rural Utilities Service (RUS), an Environmental Report will be prepared to fulfill National Environmental Policy Act (NEPA) requirements.

State-listed Species

The Minnesota Department of Natural Resources (MnDNR) Natural Heritage Information System (NHIS) database was queried in July 2014 in order to obtain information on rare and unique natural resources within one mile of the Project area. According to the NHIS database, there are no listed species within one mile of the Project area.

If additional information is needed or desired regarding the proposed transmission line project, please contact me by email at jgraves@minnkota.com or by phone at (701) 795-4221. I look forward to hearing from you.

Sincerely,

John T. Graves
Environmental Manager

Enclosure: Figure 1

| NameFirst | NameLast | Title | Organization | Address | Address2 | City | State | Zip |
|-----------|-----------------|--|---|------------------------------|-----------|---------------|-------|------------|
| James | Aakre | Chairman | Leon Township | 49209 189th Ave. | | Clearbrook | MN | 56634 |
| Richard | Aos | Clerk | Pine Lake Township | 47807 E Pine Lake Rd. | | Gonvick | MN | 56644 |
| Paul | Buer | Chairman | Pine Lake Township | 15614 500th St. | | Gonvick | MN | 56644 |
| Peter | Buesseler | EWR NW Regional Manager | DNR Division of Ecological and Water Resources | 2115 Birchmont Beach Road NE | | Bemidji | MN | 56601 |
| Tamara | Cameron | Chief, Regulatory Branch | US Army Corps of Engineers-St. Paul District | 180 5th St. E. | Suite 700 | Saint Paul | MN | 55101 |
| Craig | Collison | District 2 Engineer | MnDOT | 3920 Highway 2 W. | | Bemidji | MN | 56601 |
| John | Gunvalson | SWCD Supervisors Member, District 4 | Clearwater Soil and Water Conservation District | 312 Main Ave. N. | Suite 3 | Bagley | MN | 56621 |
| Daniel | Hecht | Environmental Services Official | Clearwater County | 213 Main Ave. N. Dept 206 | | Bagley | MN | 56621 |
| Lori | Larson | Clerk | Leon Township | 19837 500th St. | | Clearbrook | MN | 56634 |
| TJ | Melcher | District 2 Public Affairs Coordinator | MnDOT | 3920 Highway 2 W. | | Bemidji | MN | 56601 |
| Barbara | Mitchell Howard | Deputy State Historic Preservation Officer | Minnesota SHPO | 345 Kellogg Blvd W. | | St. Paul | MN | 55102-1903 |
| George | Postier | Mayor | City of Clearbrook | PO Box 62 | | Clearbrook | MN | 56634 |
| Kathy | Rasch | District Manager | Clearwater Soil and Water Conservation District | 312 Main Ave. N. | Suite 3 | Bagley | MN | 56621 |
| Kari | Roepke | NRCS District Conservationist | Clearwater Soil and Water Conservation District | 312 Main Ave. N. | Suite 3 | Bagley | MN | 56621 |
| Paul | Rydeen | SWCD Supervisors Secretary, District 3 | Clearwater Soil and Water Conservation District | 312 Main Ave. N. | Suite 3 | Bagley | MN | 56621 |
| Jamie | Schrenzel | Principal Planner, Environmental Review Unit | MN DNR | 500 Lafayette Road | Box 25 | St. Paul | MN | 55155 |
| Tony | Sullins | Field Supervisor | USFWS | 4101 American Blvd. E | | Bloomington | MN | 55425 |
| Dan | Sundquist | Mayor | City of Gonvick | 140 Cedar St. | | Gonvick | MN | 56644 |
| Jim | Zeigler | Regional Manager | MPCA Northwest Region Office | 714 Lake Ave. | Suite 220 | Detroit Lakes | MN | 56501 |

October 20, 2014

«NameFirst» «NameLast»
«Title»
«Organization»
«Address» «Address2»
«City», «State» «Zip»

**Re: Notice of Proposed Clearbrook - Clearbrook West 115 kilovolt transmission line
Clearwater County, MN
Minnkota Power Cooperative, Inc.**

Dear «NameFirst» «NameLast»:

Minnkota Power Cooperative, Inc. ("Minnkota Power") is planning to build a new 5.3-mile long, 115 kilovolt (kV) electric transmission line and a new 115/4.16 kV substation. The proposed project will start in Leon Township by tapping an existing 115 kV line via construction of a 1-way switch and the proposed project will end in Pine Lake Township at the new 115/4.16 kV substation (Figure 1). The proposed project is needed to serve a single industrial load in the Clearbrook, Minnesota area.

The purpose of this letter is to provide you notice of Minnkota Power's plan to obtain a route permit from the Minnesota Public Utilities Commission ("MPUC") for the proposed project. This letter is also intended as a request for any comments you may have regarding the project or information that your agency would like to provide relative to the project area. Minnkota Power plans to submit a Route Permit Application (RPA) to the MPUC before the end of this month. Comments or information that you are able to provide in response to this letter will be used in the preparation of the RPA as well as in the preparation of an Environmental Report for the Rural Utilities Service.

Project Description

The proposed Project involves building 5.3 miles of new 115 kV HVTL. The proposed Project will mainly use single pole, wood or steel horizontal post or horizontal brace post structures. However, two-pole or three-pole structures may be utilized where a long span is needed to cross a wetland. One three-pole structure will be utilized where the line crosses a wetland and immediately makes a turn. As shown in Figure 1, the proposed Project will start in Leon Township by tapping an existing 115 kV line via construction of a 1-way line switch and the proposed Project will end in Pine Lake Township at the proposed 115/4.16 kV Substation Location.

From its starting point in Leon Township, the proposed HVTL extends west, following existing roadway ROW and an existing distribution line along County Road 74 for approximately three miles before turning north to follow existing roadway ROW along 149th Avenue for approximately one mile. Where 149th Avenue terminates, the proposed HVTL would extend northwest along a new right-of-way for approximately one mile before turning west to connect to the proposed Substation Location. Where the proposed Project parallels County Road 74, existing low-voltage distribution lines will be removed and

buried by Clearwater-Polk Electric Cooperative. No structures will be located in wetlands. Additionally, all spans that cross wetlands will have bird flight diverters installed.

Permitting Requirements

The proposed 115 kV transmission line meets the definition of a High Voltage Transmission Line ("HVTL") under Minn. Rules Chapter 7850.1000, subp. 9. A route permit is required for the Project, for which Minnkota Power will apply.

A Certificate of Need ("CON") is not required for the Project because it is not classified as a large energy facility ("LEF") under Minn. Stat. §§ 216B.243 and 216B.2421, subd. 2(3). While the Project is a HVTL with a capacity of 100 kV or more, it is not more than 10 miles long and it does not cross a state line. Therefore, Minnkota Power does not need a CON for this Project.

The route permit proceeding will determine where the proposed facilities will be located. As part of the permitting process, the MPUC considers input from the applicant utility, interested stakeholders, local government units, state and federal agencies, and landowners who may be affected. Minnkota plans to submit an application for a route permit for the Project to the MPUC within one month. Additional environmental review will occur during the routing process. The routing process will consider environmental, land use, and other potential routing impacts, and provide the opportunity for the public to comment.

As Minnkota will be seeking funding for this project from the Rural Utilities Service (RUS), an Environmental Report will be prepared to fulfill National Environmental Policy Act (NEPA) requirements.

If additional information is needed or desired regarding the proposed transmission line project, please contact me by email at jgraves@minnkota.com or by phone at (701) 795-4221. I look forward to hearing from you.

Sincerely,



John T. Graves
Environmental Manager

Enclosure: Figure 1

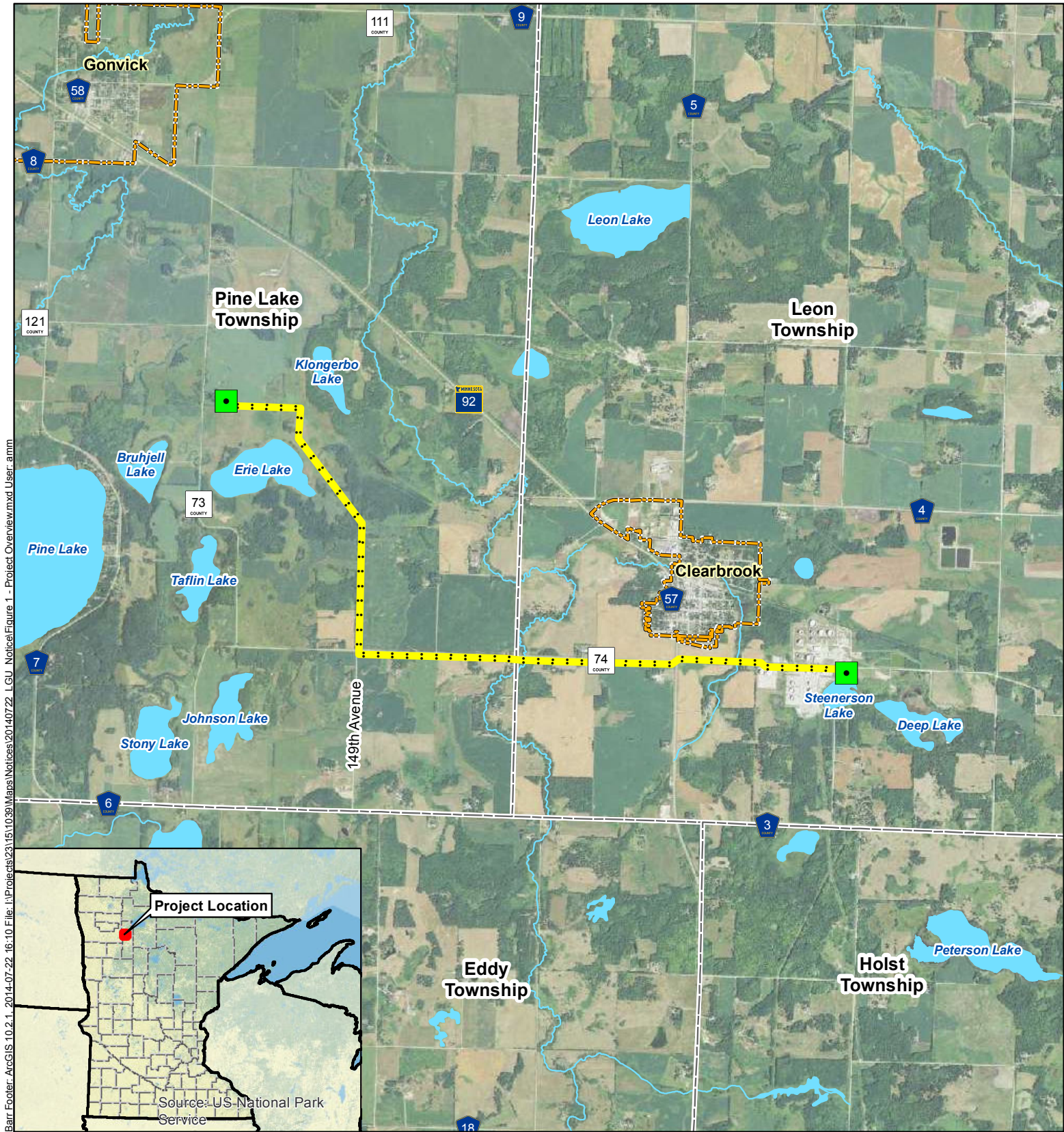

Barr Footer: ArcGIS 10.2.1, 2014-07-22 16:10 File: I:\Projects\23151\1039\Maps\notices\20140722_LGU_Notice\Figure 1 - Project Overview.mxd User: ammm

Image Source: 2013 Farm Service Agency

- Approximate Substation Location
- Proposed Clearbrook 115 kV
- Municipal Boundary
- Township Boundary
- PWI Watercourse
- PWI Basin

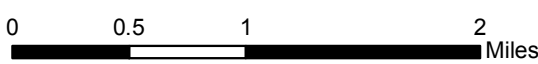

Figure 1

PROJECT OVERVIEW
 Proposed Clearbrook West
 115 kV HVTL Project
 Minnkota Power
 Clearwater County, MN

October 20, 2014

Jamie Schrenzel
Principal Planner, Environmental Review Unit Principal Planner, Environmental Review Unit
MN DNR
500 Lafayette Road Box 25
St. Paul, MN 55155

Re: Notice of Proposed Clearbrook - Clearbrook West 115 kilovolt transmission line
Clearwater County, MN
Minnkota Power Cooperative, Inc.

Dear Ms. Jamie Schrenzel:

Minnkota Power Cooperative, Inc. ("Minnkota Power") is planning to build a new 5.3-mile long, 115 kilovolt (kV) electric transmission line and a new 115/4.16 kV substation. The proposed project will start in Leon Township by tapping an existing 115 kV line via construction of a 1-way switch and the proposed project will end in Pine Lake Township at the new 115/4.16 kV substation (Figure 1). The proposed project is needed to serve a single industrial load in the Clearbrook, Minnesota area.

The purpose of this letter is to provide you notice of Minnkota Power's plan to obtain a route permit from the Minnesota Public Utilities Commission ("MPUC") for the proposed project. This letter is also intended as a request for any comments you may have regarding the project or information that your agency would like to provide relative to the project area. Minnkota Power plans to submit a Route Permit Application (RPA) to the MPUC before the end of this month. Comments or information that you are able to provide in response to this letter will be used in the preparation of the RPA as well as in the preparation of an Environmental Report for the Rural Utilities Service.

Project Description

The proposed Project involves building 5.3 miles of new 115 kV HVTL. The proposed Project will mainly use single pole, wood or steel horizontal post or horizontal brace post structures. However, two-pole or three-pole structures may be utilized where a long span is needed to cross a wetland. One three-pole structure will be utilized where the line crosses a wetland and immediately makes a turn. As shown in Figure 1, the proposed Project will start in Leon Township by tapping an existing 115 kV line via construction of a 1-way line switch and the proposed Project will end in Pine Lake Township at the proposed 115/4.16 kV Substation Location.

From its starting point in Leon Township, the proposed HVTL extends west, following existing roadway ROW and an existing distribution line along County Road 74 for approximately three miles before turning north to follow existing roadway ROW along 149th Avenue for approximately one mile. Where 149th Avenue terminates, the proposed HVTL would extend northwest along a new right-of-way for approximately one mile before turning west to connect to the proposed Substation Location. Where the proposed Project parallels County Road 74, existing low-voltage distribution lines will be removed and

buried by Clearwater-Polk Electric Cooperative. No structures will be located in wetlands. Additionally, all spans that cross wetlands will have bird flight diverters installed.

Permitting Requirements

The proposed 115 kV transmission line meets the definition of a High Voltage Transmission Line ("HVTL") under Minn. Rules Chapter 7850.1000, subp. 9. A route permit is required for the Project, for which Minnkota Power will apply.

A Certificate of Need ("CON") is not required for the Project because it is not classified as a large energy facility ("LEF") under Minn. Stat. §§ 216B.243 and 216B.2421, subd. 2(3). While the Project is a HVTL with a capacity of 100 kV or more, it is not more than 10 miles long and it does not cross a state line. Therefore, Minnkota Power does not need a CON for this Project.

The route permit proceeding will determine where the proposed facilities will be located. As part of the permitting process, the MPUC considers input from the applicant utility, interested stakeholders, local government units, state and federal agencies, and landowners who may be affected. Minnkota plans to submit an application for a route permit for the Project to the MPUC within one month. Additional environmental review will occur during the routing process. The routing process will consider environmental, land use, and other potential routing impacts, and provide the opportunity for the public to comment.

As Minnkota will be seeking funding for this project from the Rural Utilities Service (RUS), an Environmental Report will be prepared to fulfill National Environmental Policy Act (NEPA) requirements.

State-listed Species

The Minnesota Department of Natural Resources (MnDNR) Natural Heritage Information System (NHIS) database was queried in July 2014 in order to obtain information on rare and unique natural resources within one mile of the Project area. According to the NHIS database, there are no listed species within one mile of the Project area.

If additional information is needed or desired regarding the proposed transmission line project, please contact me by email at jgraves@minnkota.com or by phone at (701) 795-4221. I look forward to hearing from you.

Sincerely,

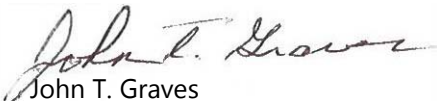
John T. Graves
Environmental Manager

Enclosure: Figure 1

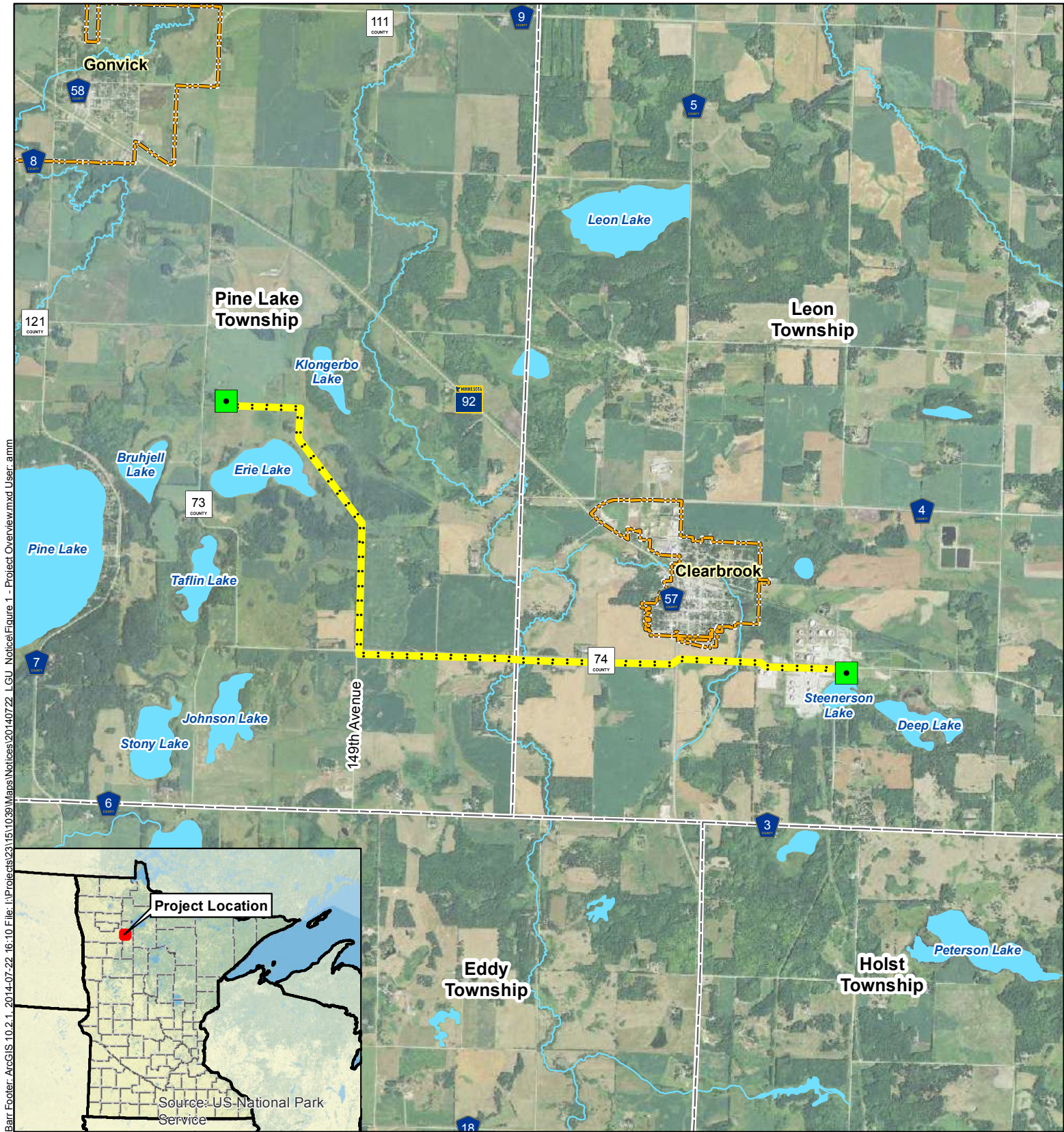

Barr Footer: ArcGIS 10.2.1, 2014-07-22 16:10 File: I:\Projects\23151\1039\Maps\notices\20140722_LGU_Notice\Figure 1 - Project Overview.mxd User: ammm

Image Source: 2013 Farm Service Agency

- Approximate Substation Location
- Proposed Clearbrook 115 kV
- Municipal Boundary
- Township Boundary
- PWI Watercourse
- PWI Basin

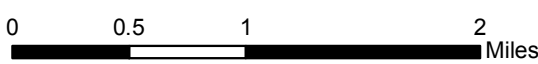

Figure 1

PROJECT OVERVIEW
 Proposed Clearbrook West
 115 kV HVTL Project
 Minnkota Power
 Clearwater County, MN

October 20, 2014

Tony Sullins
Field Supervisor
USFWS
4101 American Blvd. E
Bloomington, MN 55425

Re: Notice of Proposed Clearbrook - Clearbrook West 115 kilovolt transmission line
Clearwater County, MN
Minnkota Power Cooperative, Inc.

Dear Mr. Tony Sullins:

Minnkota Power Cooperative, Inc. ("Minnkota Power") is planning to build a new 5.3-mile long, 115 kilovolt (kV) electric transmission line and a new 115/4.16 kV substation. The proposed project will start in Leon Township by tapping an existing 115 kV line via construction of a 1-way switch and the proposed project will end in Pine Lake Township at the new 115/4.16 kV substation (Figure 1). The proposed project is needed to serve a single industrial load in the Clearbrook, Minnesota area.

The purpose of this letter is to provide you notice of Minnkota Power's plan to obtain a route permit from the Minnesota Public Utilities Commission ("MPUC") for the proposed project. This letter is also intended as a request for any comments you may have regarding the project or information that your agency would like to provide relative to the project area. Minnkota Power plans to submit a Route Permit Application (RPA) to the MPUC before the end of this month. Comments or information that you are able to provide in response to this letter will be used in the preparation of the RPA as well as in the preparation of an Environmental Report for the Rural Utilities Service

Project Description

The proposed Project involves building 5.3 miles of new 115 kV HVTL. The proposed Project will mainly use single pole, wood or steel horizontal post or horizontal brace post structures. However, two-pole or three-pole structures may be utilized where a long span is needed to cross a wetland. One three-pole structure will be utilized where the line crosses a wetland and immediately makes a turn. As shown in Figure 1, the proposed Project will start in Leon Township by tapping an existing 115 kV line via construction of a 1-way line switch and the proposed Project will end in Pine Lake Township at the proposed 115/4.16 kV Substation Location.

From its starting point in Leon Township, the proposed HVTL extends west, following existing roadway ROW and an existing distribution line along County Road 74 for approximately three miles before turning north to follow existing roadway ROW along 149th Avenue for approximately one mile. Where 149th Avenue terminates, the proposed HVTL would extend northwest along a new right-of-way for approximately one mile before turning west to connect to the proposed Substation Location. Where the proposed Project parallels County Road 74, existing low-voltage distribution lines will be removed and

buried by Clearwater-Polk Electric Cooperative. No structures will be located in wetlands. Additionally, all spans that cross wetlands will have bird flight diverters installed.

Permitting Requirements

The proposed 115 kV transmission line meets the definition of a High Voltage Transmission Line ("HVTL") under Minn. Rules Chapter 7850.1000, subp. 9. A route permit is required for the Project, for which Minnkota Power will apply.

A Certificate of Need ("CON") is not required for the Project because it is not classified as a large energy facility ("LEF") under Minn. Stat. §§ 216B.243 and 216B.2421, subd. 2(3). While the Project is a HVTL with a capacity of 100 kV or more, it is not more than 10 miles long and it does not cross a state line. Therefore, Minnkota Power does not need a CON for this Project.

The route permit proceeding will determine where the proposed facilities will be located. As part of the permitting process, the MPUC considers input from the applicant utility, interested stakeholders, local government units, state and federal agencies, and landowners who may be affected. Minnkota plans to submit an application for a route permit for the Project to the MPUC within one month. Additional environmental review will occur during the routing process. The routing process will consider environmental, land use, and other potential routing impacts, and provide the opportunity for the public to comment.

As Minnkota will be seeking funding for this project from the Rural Utilities Service (RUS), an Environmental Report will be prepared to fulfill National Environmental Policy Act (NEPA) requirements.

Federally-listed Species

According to the U.S. Fish and Wildlife Service's (USFWS) State and County Distribution list for Clearwater County, Minnesota, received in July of 2014, Clearwater County is within the overall range of the Canada lynx (*Lynx Canadensis*; federally threatened). Due to the industrial nature of the Project area and the lack of desirable Canada lynx habitat (dense forest), the proposed Project will have *no effect* on the Canada lynx.

If additional information is needed or desired regarding the proposed transmission line project, please contact me by email at jgraves@minnkota.com or by phone at (701) 795-4221. I look forward to hearing from you.

Sincerely,

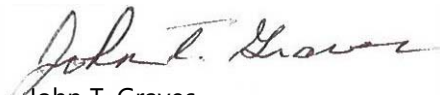

John T. Graves

Environmental Manager

Enclosure: Figure 1

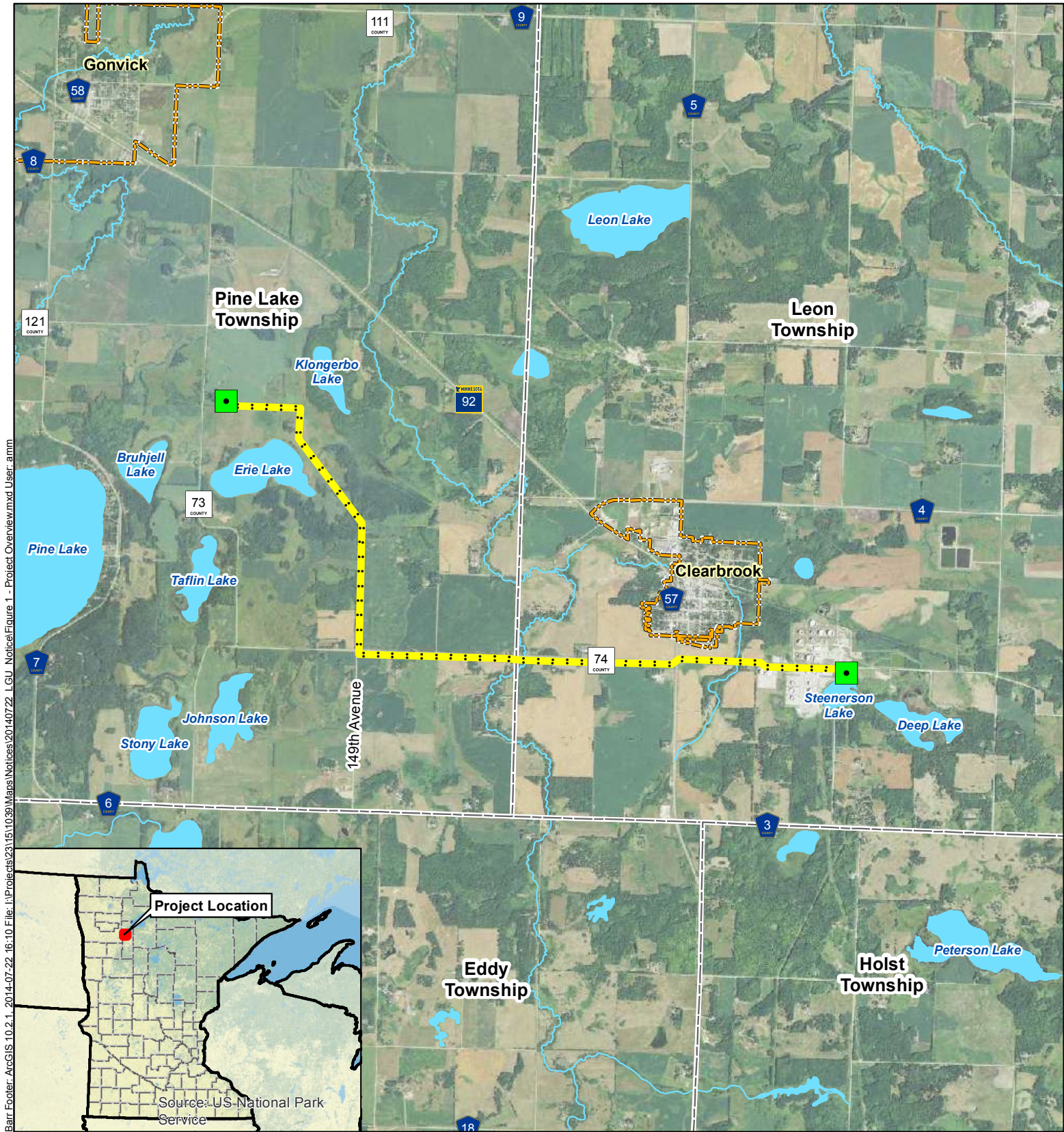

Barr Footer: ArcGIS 10.2.1, 2014-07-22 16:10 File: I:\Projects\23151\1039\Maps\notices\20140722_LGU_Notice\Figure 1 - Project Overview.mxd User: ammm

Image Source: 2013 Farm Service Agency

- Approximate Substation Location
- Proposed Clearbrook 115 kV
- Municipal Boundary
- Township Boundary
- PWI Watercourse
- PWI Basin

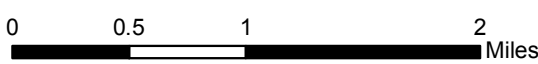

Figure 1

PROJECT OVERVIEW
 Proposed Clearbrook West
 115 kV HVTL Project
 Minnkota Power
 Clearwater County, MN



Clearwater County Environmental Services

213 Main Ave N Dept. 206
Bagley, MN 56621-8304
www.co.clearwater.mn.us

Phone: 218/694-6183
Fax: 218/694-6244

October 22, 2014

Attn: John T. Graves, Environmental Manager
Minnkota Power Cooperative, Inc.
1822 Mill Road
PO Box 13200
Grand Forks, ND 58203

RE: Proposed Clearbrook – Clearbrook West 115 KV transmission line

Dear Mr. Graves:

I have received your letter of October 20 which was to provide notice of Minnkota's proposed transmission line project within Clearwater County, referenced above. Thank you for the opportunity to provide comment on this project.

Clearwater County enforces land use regulations only within shoreland areas, pursuant to Minnesota DNR's Shoreland Management program, so my comments only pertain to portions of the project that lie within shoreland areas, defined as land located within 1,000 feet of a lake and/or 300 feet of a river or stream. The County does not enforce any land use regulation that might pertain to this transmission line project outside of shoreland areas.

On the project location map you sent me, I can see two stream crossings and one lake where work may take place in areas that would be considered shoreland, as follows:

Stream crossing – Section 29/32 Leon Township, just under ½ mi. E of Hwy 92

Stream crossing – Section 30/31 Leon Township, just under 1 mi. W of Hwy 92

Lake – along NE side of Erie Lake in Section 23, Pine Lake Township.

Although there is no language in the shoreland regulations that directly addresses transmission lines, there is language addressing removal of vegetation which I assume will be a part of the project. Specifically, item #1 in Section 901 discusses intensive vegetative clearing and I've cut and pasted the language along with relevant definitions below for your review. If you would like, you may view the ordinance in its entirety on the County's website.

Section 901. Vegetative Alterations

Removal or alteration of vegetation, except for agricultural and forest management uses as regulated by Section 906 and 907 of this Ordinance, is allowed subject to the following standards:

1. Intensive vegetative clearing within the shore and bluff impact zones and on steep slopes is not allowed. Intensive vegetative clearing for forest land conversion to another use outside of these areas is allowed as a conditional use provided an erosion control and sedimentation plan is developed and approved by the Clearwater Soil and Water Conservation district in which the property is located.

INTENSIVE VEGETATIVE CLEARING. The substantial removal of trees or shrubs in a contiguous patch, strip, row or block.

SHORE IMPACT ZONE. Land located between the ordinary high water level of a public water and a line parallel to it at a setback of 50 percent of the structure setback.

I haven't had any previous experience with transmission line projects with respect to these regulations, but the way I interpret this is the clearing of trees that would generally be associated with transmission line right-of-way would be prohibited in the shore impact zone, which in this case would be 75 feet along Erie Lake and 50 feet at both stream crossings. In effect, a 75 or 50 foot buffer of vegetation, if it exists now, would need to be left along the shoreline at each site.

Obviously this kind of work occurs all over Minnesota when powerlines are constructed, and possibly this conflict with the state shoreland regulations is resolved somehow through the MPUC route permit process. If so, you may disregard this letter and I will assume that is the case. Otherwise, please consider my response and contact me if necessary to work toward some kind of reasonable solution to accommodate both the project and the regulations as best we can.

Sincerely,

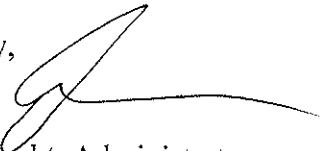

Daniel Hecht, Administrator
Environmental Services

STATE HISTORIC PRESERVATION OFFICE

November 14, 2014

Mr. John T. Graves
Minnkota Power Cooperative
PO Box 13200
Grand Forks, ND 58208-3200

RE: Clearbrook West 115 kV transmission line
T149 R37 S29, 30, 31, 32 & T149 R38 S23, 25, 26, 35, 36, Clearwater County
SHPO Number: 2015-0325

Dear Mr. Graves:

Thank you for the opportunity to comment on the above project. It is being reviewed pursuant to the responsibilities given to the State Historic Preservation Officer by the National Historic Preservation Act of 1966 and implementing federal regulations at 36 CFR 800, and pursuant to the responsibilities given to the Minnesota Historical Society by the Minnesota Historic Sites Act and the Minnesota Field Archaeology Act.

Under 36 CFR 800.4(b-c) it is the federal agency's responsibility to identify and evaluate any historic properties that may be affected by the proposed project. In absence of this information and due to the nature and location of the proposed project, we are unable to complete project review. In order to proceed, we recommend that an archaeological survey be completed meeting the requirements of the Secretary of the Interior's Standards for Identification and Evaluation. For a list of consultants who have expressed an interest in undertaking such surveys, please visit the website preservationdirectory.mnhs.org, and select "Archaeologists" in the "Search by Specialties" box.

We will reconsider the need for survey if the project area can be documented as previously surveyed or disturbed. Any previous survey work must meet contemporary standards. **Note:** plowed areas and right-of-way are not automatically considered disturbed. Archaeological sites can remain intact beneath the plow zone and in undisturbed portions of the right-of-way.

If you have any questions regarding our review, please contact Kelly Gragg-Johnson at (651) 259-3455.

Sincerely,

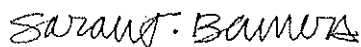

Sarah J. Beimers, Manager
Government Programs and Compliance

STATE HISTORIC PRESERVATION OFFICE

September 4, 2014

Sara Ploetz
Enbridge
North Dakota Pipeline Company
1409 Hammond Avenue, Second Floor
Superior, WI 54880

RE: Sandpiper Pipeline Project
Cass, Kittson, Red Lake and St. Louis Counties
SHPO Number: 2013-1826

Dear Ms. Ploetz:

Thank you for the opportunity to comment on the above project. Information received in our office on 6 August 2014 has been reviewed pursuant to the responsibilities given to the Minnesota Historical Society by the Minnesota Historic Sites Act and the Minnesota Field Archaeology Act.

As requested in your correspondence dated 5 August 2014, David Mather, SHPO National Register Archaeologist has completed a review of the *2013 Minnesota Archaeological Reconnaissance Studies* (April 2014) report as prepared by Commonwealth Cultural Resources Group and Merjent. His comments and recommendations are summarized below.

General Report Comments

Regarding the Phase I survey, the general approach seems appropriate. However, the report says that the survey protocol is described further in the Appendices, but we could not find this information. It appears from the survey maps that some areas identified as needing survey have not yet been surveyed. Your accompanying correspondence states that routing is still being determined, so we assume additional survey reports will be submitted as the routing is finalized and project review progresses. It will be important to somehow track these additional survey areas in relation to results we are reviewing now.

Specific Site Recommendations, by County:

Polk County

21PL91, 21PL106, 21PL103, 21PL104, 21PL93, 21PL99, 21PL95, 21PL94, 21PL101, CCRG603_CAC-03, 21PL100 – We agree that these sites are not eligible for listing in the National Register of Historic Places (NRHP).

21PL102 – Phase II evaluation was conducted at this site, with a recommendation that it is potentially eligible, pending a geomorphology study. We believe that the geomorphology study will be useful, but that the current data demonstrates that the site is eligible for listing in the NRHP.

21PL96/97 – Phase II evaluation recommends this site(s) as eligible for listing in the NRHP. We agree.

21PL105 – Phase I conducted with recommendation of Phase II evaluation needed. We agree.

21PL92 – Phase I conducted with recommendation of not eligible. We do not believe that the current data is sufficient to support this recommendation. A Phase II evaluation should be conducted to determine eligibility.

21PL98 – Phase II evaluation conducted with recommendation for additional Phase II. We agree that this would be helpful, but that the current data is sufficient to demonstrate it is eligible for listing in the NRHP.

Red Lake County

21RL31 (Note: Red Lake County is **RL** and not **RE**, please correct the references to this site in the report) We agree that this site is not eligible for listing in the NRHP.

Clearwater County

21CE79, 21CE81, 21CE80, 21CE78, CCRG04_MCT_06, 21CE75, 21CE77, 21CE66 – We agree that these sites are not eligible for listing in the NRHP.

21CE76 – Phase I conducted with recommendation of not eligible. We do not believe that the current data is sufficient to support this recommendation. A Phase II evaluation should be conducted to determine eligibility.

Hubbard County

21HB86, 21HB85 – We agree that these sites are not eligible for listing in the NRHP.

21HB81 – Phase I conducted with recommendation of not eligible. We do not believe that the current data is sufficient to support this recommendation. A Phase II evaluation should be conducted to determine eligibility.

21HB79 – Phase I conducted with recommendation of not eligible. We do not believe that the current data is sufficient to support this recommendation. A Phase II evaluation should be conducted to determine eligibility.

21HB82 – Phase I conducted with recommendation that Phase II evaluation is needed. We agree that this is necessary. It is disappointing, however, that there is so little information about the unusual artifacts observed at this site (daub fragments and charred botanical remains). It is surprising that the

artifacts were not collected, or at least photographed in the field. These are presumably fragile materials, and it seems likely that an opportunity has been lost. It's possible that they will still be there when/if the Phase II evaluation is conducted, but it will be a matter of luck if that's the case. This is an example that calls into question the appropriateness of no-collection archaeological surveys.

21HB84 – Phase I conducted with recommendation that Phase II evaluation is needed. We agree that this is necessary.

21HB89 – Phase I conducted with recommendation that Phase II evaluation is needed. We agree that this is necessary.

21HB87 – Phase I conducted with recommendation that the portion of the site within the survey corridor is apparently not eligible (?). We recommend that a Phase II evaluation be conducted at this site to determine eligibility.

21HB80 – Phase I conducted with recommendation that the portion of the site within the survey corridor is apparently not eligible (?). We recommend that a Phase II evaluation be conducted at this site to determine eligibility.

21HB88 – Phase I conducted with recommendation that Phase II evaluation is needed. We agree that this is necessary.

21HB83 – Phase I conducted with recommendation that Phase II evaluation is needed. We agree that this is necessary.

Cass County

CCRG01_CJY_02 – We agree that this site is not eligible for the NRHP.

21CA755 – Phase I conducted with recommendation that the site is not eligible. We agree, but consultation should occur with the Office of the State Archaeologist regarding potential need for burial authentication.

21CA736 – Phase I conducted with recommendation that Phase II evaluation is needed. We agree that this is necessary.

Aitkin County

21AK125, 21AK126 - We agree that these sites are not eligible for listing in the NRHP.

21AK127- Historic cemetery - Consultation with the Office of the State Archaeologist is needed.

Carlton County

21CL47, 21CL43, 21CL46 - We agree that these sites are not eligible for listing in the NRHP.

21CL42 – Phase I conducted with recommendation of not eligible. We do not believe that the current data is sufficient to support this recommendation. A Phase II evaluation should be conducted to determine eligibility.

Please note that this comment letter does not address the requirements of Section 106 of the National Historic Preservation Act of 1966 and 36CFR800, Procedures of the Advisory Council on Historic Preservation for the protection of historic properties.

We look forward to continuing consultation with Enbridge and the Minnesota Public Utilities Commission, and also with the St. Paul District-U.S. Army Corps of Engineers, as this project's environmental review is completed.

Please feel free to contact me at 651-259-3456 or by e-mail at sarah.beimers@mnhs.org if you have any questions or concerns regarding our comments and recommendations.

Sincerely,

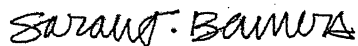

Sarah J. Beimers, Manager
Government Programs and Compliance

cc: Scott Elk, Minnesota Public Utilities Commission
Brad Johnson, USACE, Regulatory Branch
Michael Madsen, Merjent

John Graves

From: Frisco, Stephen (DOT) <stephen.frisco@state.mn.us>
Sent: Friday, October 31, 2014 1:32 PM
To: John Graves
Cc: Kotch, Stacy (DOT); Collison, Craig (DOT); Zigman, James (DOT)
Subject: Proposed Clearbrook 115 Kv line
Attachments: 4463_001.pdf

John- Thank you for the early notice and the opportunity to comment. With the limited information available it appears as though the crossing may be at skewed angle. MnDOT does prefer perpendicular crossings. We look forward to commenting further during the MPUC routing process.

Sincerely,

Stephen Frisco
Roadway Regulations Supervisor
218-755-6553

From: Kestner, Nathan (DNR) [mailto:nathan.kestner@state.mn.us]
Sent: Monday, June 29, 2015 2:00 PM
To: Terry Johnson
Cc: Walker, Michele (DNR)
Subject: RE: Clearbrook-Clearbrook west 115 kV transmission line project

Terry-

Based on the structure locations depicted on the attached drawing, description of work described in the emails below, and phone conversation dated 6-26-15 and 6-29-15; we do not believe that proposed work will have any detrimental effects on the calcareous fen situated to the south along the northern shore of Steenersen Lake. Should your project change to involve work beyond that described below or include dewatering, please contact DNR Regional Groundwater Specialist Michelle Walker at 218-308-2664.

Thanks for the opportunity to provide this early coordination review.

Nathan Kestner
Regional Environmental Assessment Ecologist - Reg 1
MN DNR Division of Ecological & Water Resources, NW Region
2115 Birchmont Beach Rd NE, Bemidji, MN 56601
218-308-2672, 218-755-4066 (fax)
nathan.kestner@state.mn.us

From: Terry Johnson [mailto:tjohnson@minnkota.com]
Sent: Friday, June 26, 2015 2:37 PM
To: Kestner, Nathan (DNR)
Subject: RE: Clearbrook-Clearbrook west 115 kV transmission line project

The direct imbedding depth is designed to be from 10-12 feet below grade. They would be drilled using a digger derrick auger sized for the base of the structure. As of right now, the single pole structures may be of either wood or steel composition. There would be no de-watering. If the water table is encountered with sluffing conditions. A partial casing would simply be inserted prior to backfilling. Please let me know if you have additional questions.

From: Kestner, Nathan (DNR) [mailto:nathan.kestner@state.mn.us]
Sent: Friday, June 26, 2015 2:29 PM
To: Terry Johnson
Subject: RE: Clearbrook-Clearbrook west 115 kV transmission line project

Terry-

Can you provide a description of each structure that will help us to better visualize what they are and what it takes to construct (i.e. are the buildings, power poles, etc.)? Also, please indicate if any dewatering will be needed. Thank you.

Nathan Kestner
Regional Environmental Assessment Ecologist - Reg 1
MN DNR Division of Ecological & Water Resources, NW Region
2115 Birchmont Beach Rd NE, Bemidji, MN 56601
218-308-2672, 218-755-4066 (fax)
nathan.kestner@state.mn.us

From: Terry Johnson [<mailto:tjohnson@minnkota.com>]
Sent: Friday, June 26, 2015 12:53 PM
To: Kestner, Nathan (DNR)
Subject: RE: Clearbrook-Clearbrook west 115 kV transmission line project

Nathan, thanks for your help. As we talked about, I am providing you with a map view of that portion of the project to aid your review. The various lines may be a little confusing. I'll try and clear that up some. First of all, here is info from engineering referring to the structure(s) and to scale vs print-out or copy size. Our connection is to an existing OTP 115 kV line at Structure 1. Structure 1 is a switch that OTP is designing and will be constructing for our project. The pdf is set up for 22" x 34" sheet at 100 scale. If it is printed on 11" x 17", it is 200 scale.

Therefore, with structure 1 as well as structures 2 & 3 being on the north side of the road at the locations shown, I hope this helps you in further evaluating this proposed project. Again, please let me know if you have questions.

From: Kestner, Nathan (DNR) [<mailto:nathan.kestner@state.mn.us>]
Sent: Friday, June 26, 2015 10:42 AM
To: Terry Johnson
Cc: Frantz, Kate (DNR)
Subject: RE: Clearbrook-Clearbrook west 115 kV transmission line project

Terry-

Sorry for the lateness of this response. If it is still possible, please include these consideration within the scope of the environmental assessment. I have also attached an early coordination letter provided to Enbridge that generally describes how DNR participate in utility projects and reiterates what I discussed with you this morning.

DNR Early Coordination Comments:

Based on a desktop review, it appears that your project will involve construction in close proximity to a calcareous fen and involve public water crossings.

The calcareous fen mentioned above is located along the north shore of Steenerson Lake near the proposed substation. Calcareous fens are rare and distinctive peat accumulating wetlands which have additional legal protected in Minnesota. Calcareous fens are designated as "outstanding resource value waters" in water quality regulations administered by the MPCA (Minnesota Rules part 7050.0180) and they are given special protection through Minnesota Rules part 8420.1010 - 8240.1060. The Wetlands Conservation Act (WCA), authorized by Minnesota Statutes 103G.223, states that calcareous fens may not be filled, drained, or otherwise degraded, wholly or partially, by any activity, except as provided for in a management plan (i.e. Fen Management Plan [FMP]) approved by the Commissioner of the Department of Natural Resources.

Many of the unique characteristics of calcareous fens result from the upwelling of groundwater through calcareous substrates. Because of their dependence on delicate groundwater hydrology, calcareous fens can be indirectly affected

by activities several miles away from the fen. **Due to the unique characteristics of these resources and difficulty in approving impacts, DNR recommends that avoidance of impacts to calcareous fens be given high priority. Please contact DNR Regional Groundwater Specialist Michelle Walker at 218-308-2664 for questions about calcareous fens and FMP requirements. To help us further review your project, please provide us a copy of your substation site plan. Based on our review of that plan, we will determine additional requirements .**

Project developers intending to cross over, under, or across any state land or public water with any utility (pipelines, power lines, etc.) need to first secure a DNR license to cross (Minnesota Statue 84.415). Information on how to obtain a License for Utility can be found at http://www.dnr.state.mn.us/permits/utility_crossing/index.html. DNR Division of Lands and Minerals (LAM) coordinates DNR staff license reviews and issues utility licenses to cross public waters and state lands managed by the DNR. Please use the link above or call DNR LAM at 218-308-2627 (northwest region) to identify all requirements.

Many times utility projects require dewatering during construction. A water use (appropriation) permit from DNR Waters is required for all users withdrawing more than 10,000 gallons of water per day or 1 million gallons per year. Additional information about DNR water use permits is available at http://www.dnr.state.mn.us/waters/watermgmt_section/appropriations/permits.html

I am encouraged to see that bird diverters will be used as a means to minimize avian mortality as a result of collisions. We would ask that diverters be placed on flyways between and across water resources.

Thanks for the opportunity for review and we may have additional input as the EA and route permit application is made available for review.

Nathan Kestner
Regional Environmental Assessment Ecologist - Reg 1
MN DNR Division of Ecological & Water Resources, NW Region
2115 Birchmont Beach Rd NE, Bemidji, MN 56601
218-308-2672, 218-755-4066 (fax)
nathan.kestner@state.mn.us

From: Terry Johnson [<mailto:tjohnson@minnkota.com>]
Sent: Friday, June 26, 2015 9:56 AM
To: Kestner, Nathan (DNR)
Subject: Clearbrook-Clearbrook west 115 kV transmission line project

Nathan it was good to talk with you regarding this project. Please find attached for your review as requested our letter submitted to Jamie as we discussed. We would appreciate your review and comment on this as we are on the verge of submitting our draft RPA and EA for the RUS. Please let me know if you have questions.

Terry Johnson
Environmental Engineer
P. 701-795-4293
Minnkota Power Cooperative, Inc.
tjohnson@minnkota.com

This email has been scanned for email related threats and delivered safely by Mimecast.
For more information please visit <http://www.mimecast.com>

This email has been scanned for email related threats and delivered safely by Mimecast.
For more information please visit <http://www.mimecast.com>

This email has been scanned for email related threats and delivered safely by Mimecast.
For more information please visit <http://www.mimecast.com>

This email has been scanned for email related threats and delivered safely by Mimecast.
For more information please visit <http://www.mimecast.com>



| | | | | | | | |
|------|-----------|------|-----------|----|-----------------|-------------------------------|--------------|
| | | | | | DRAWN JPB | CLEARBROOK TO CLEARBROOK WEST | |
| | | | | | DATE 6/26/15 | E CONNECTION | |
| | | | | | APPROVED JPB | | |
| | | | | | PROJECT # 20667 | SCALE 1" = 100' | SHEET 1 OF 1 |
| DATE | PROJECT # | WO # | REVISIONS | BY | WO # 485337 | DWG.NO. | |



TELEPHONE MEMORANDUM

TO: FILE
FROM: TERRY JOHNSON
SUBJECT: CLEARBROOK-CLEARBROOK WEST LINE PROJECT
DATE: 6-26-15
CC:

Call made to: USFWS Bloomington Office (612)-725-3548; 6-25-15 @ 08:46 AM. Asked for Tony Sullins (field supervisor where our October 20, 2014 letter was sent to). I was informed that Tony was no longer with the Bloomington office and that Lisa Mandell was the person to contact regarding this project. I obtained her e-mail address from the administrative assistance and e-mailed her the letter with map figure that we previously sent at 10:10 AM.

6-26-15 11:22 AM; called for Lisa again and she said she would issue a response as soon as their schedule permitted.