

SEE SHEET C.415

SEE SHEET C.417

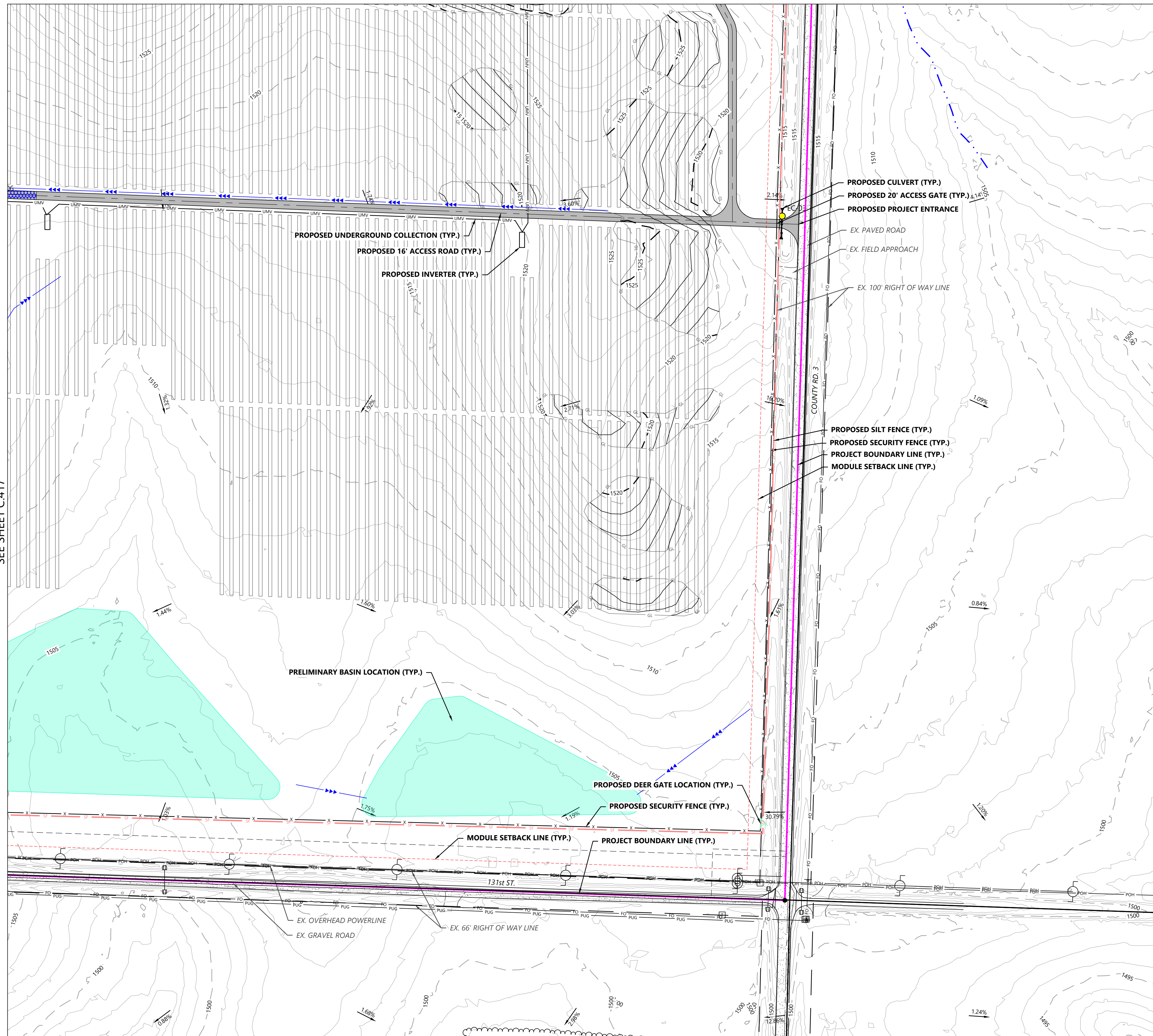

LEGEND:

- PROJECT BOUNDARY
- - - EX. EASEMENT LINE
- - - EX. SECTION LINE
- EX. PARCEL LINE
- RIGHT-OF-WAY LINES
- EX. OVERHEAD POWER
- EX. UNDERGROUND COLLECTION
- EX. FIBER OPTIC
- EX. PAVED ROAD
- EX. GRAVEL ROAD
- EX. STREAM CHANNEL
- EX. WETLAND
- EX. STRUCTURE
- EX. CULVERT
- EX. SIGN
- EX. TELEPHONE PEDESTAL
- EX. INDEX CONTOUR
- EX. INTERVAL CONTOUR
- PROPOSED INDEX CONTOUR
- PROPOSED INTERVAL CONTOUR
- PROPOSED SOLAR ARRAY WITH INVERTER
- PROPOSED WETLAND SETBACK
- PROPOSED SOLAR ARRAY BOUNDARY
- PROPOSED MODULE SETBACK
- PROPOSED ACCESS ROAD
- PROPOSED SECURITY FENCE
- PROPOSED LAYDOWN YARD
- PROPOSED O&M LOCATION
- PROPOSED SUBSTATION LOCATION
- PROPOSED EXISTING SUBSTATION EXPANSION LOCATION
- PROPOSED SCREENING
- PROPOSED LOW WATER CROSSING
- PROPOSED SILT FENCE
- PROPOSED CULVERT
- PROPOSED PRELIM DRAINAGE BASIN
- PROPOSED DISTURBANCE LIMITS
- PROPOSED GRADING LIMITS
- PROPOSED GRADE BREAK SWALES
- PROPOSED DRAINAGE CROSSING
- PROPOSED ENTRANCE CULVERT
- PROPOSED UNDERGROUND COLLECTION
- PROPOSED OVERHEAD COLLECTION
- PROPOSED DEER GATE LOCATION

NOTES:

1. SEE SITE PLAN SHEETS C.401 THRU C.426 FOR LAYOUT OF ARRAY AND FACILITY FEATURES.
2. SITE PREPARATION INCLUDES BUT IS NOT LIMITED TO CLEARING/GRUBBING, MINOR GRADING, COMPACTION, MOWING OF VEGETATION, AND RESTABILIZATION OF DISTURBED AREA.
3. MINOR SURFACE SMOOTHING MAY OCCUR IN AREAS WHERE GRADING IS NOT PROPOSED FOR SAFETY OR SOLAR ARRAY INSTALLATION.
4. CONTRACTOR SHALL INSTALL ALL PERIMETER EROSION AND SEDIMENT CONTROL DEVICES PRIOR TO UPSLOPE DISTURBANCE ACTIVITIES.
5. ACCESS ROADS WILL BE CONSTRUCTED TO MATCH THE SURROUNDING EXISTING GROUND ELEVATIONS TO ALLOW THE CONTINUATION OF DRAINAGE PATTERNS. A CROWNED OR CONTINUOUS CROSS SLOPE WILL BE PROVIDED BASED ON SITE CONDITIONS.
6. OVERALL DRAINAGE PATTERNS WILL NOT BE ALTERED WITH SOLAR FACILITY.

KEY MAP

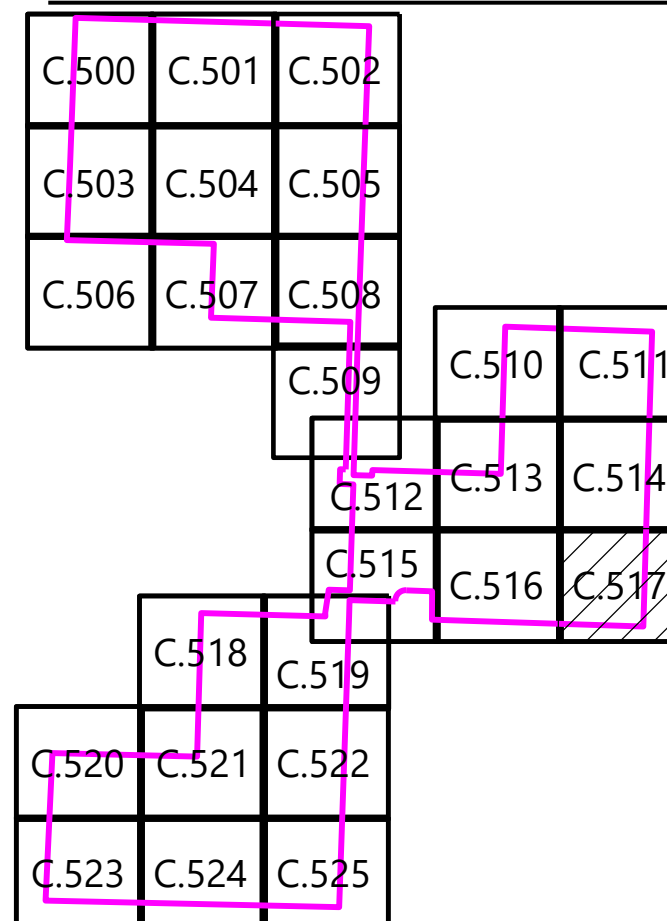

**Westwood**

Phone (952) 937-5150 12701 Whitewater Drive, Suite #300  
 Fax (952) 937-5822 Minnetonka, MN 55343  
 TollFree (888) 937-5150 westwoodps.com  
 Westwood Professional Services, Inc.



8400 Normandale Lake Blvd, Suite 1200  
 Bloomington, MN 55347

REVISIONS:

#	DATE	COMMENT	BY	CHK
A	05/01/2023	Permit Plans	MB	BV KA

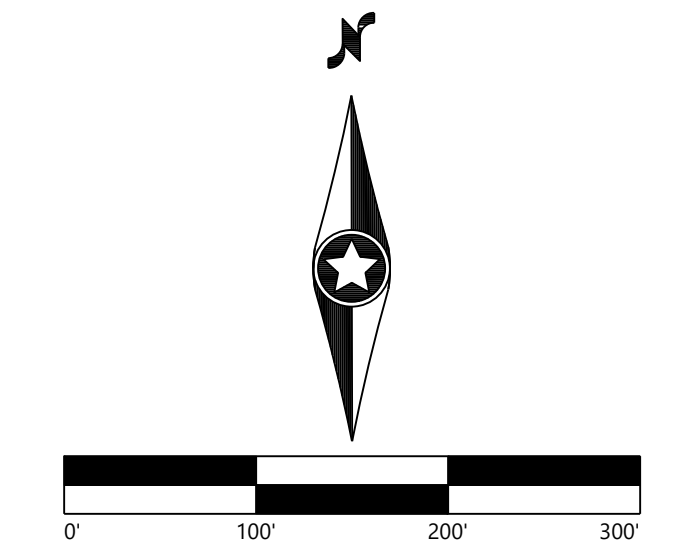

# Elk Creek Solar Project

Rock County, MN

Grading and Drainage  
 Plan - 18

NOT FOR CONSTRUCTION

DATE: 05/01/2023 REV:  
 SHEET: C.517 A

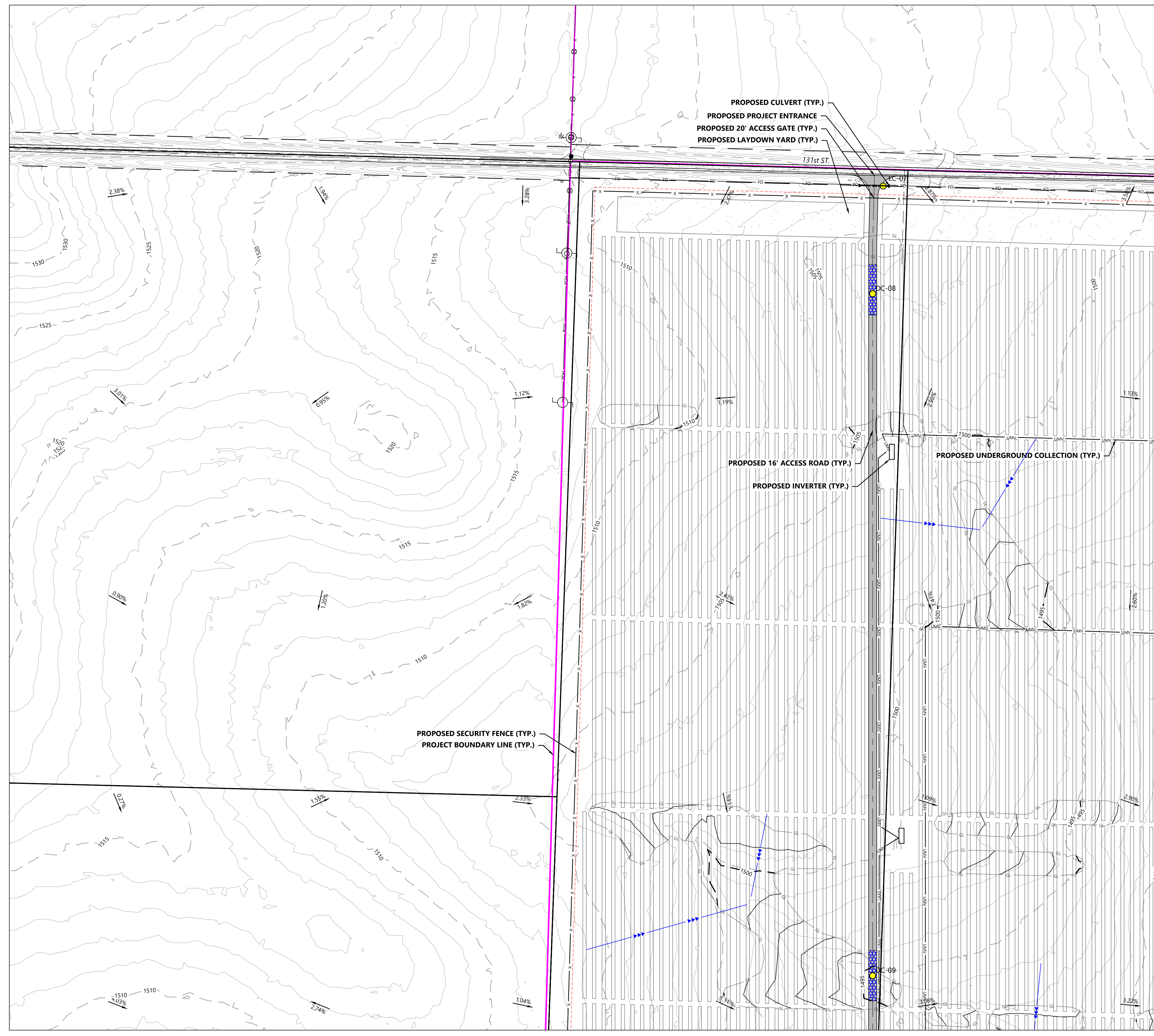

**LEGEND:**

- PROJECT BOUNDARY
- - - EX. EASEMENT LINE
- - - EX. SECTION LINE
- EX. PARCEL LINE
- RIGHT-OF-WAY LINES
- OPH EX. OVERHEAD POWER
- PUG EX. UNDERGROUND COLLECTION
- FO EX. FIBER OPTIC
- EX. PAVED ROAD
- EX. GRAVEL ROAD
- EX. STREAM CHANNEL
- EX. WETLAND
- EX. STRUCTURE
- EX. CULVERT
- EX. SIGN
- EX. TELEPHONE PEDESTAL
- 900 EX. INDEX CONTOUR
- 910 EX. INTERVAL CONTOUR
- PROPOSED INDEX CONTOUR
- PROPOSED INTERVAL CONTOUR
- PROPOSED SOLAR ARRAY WITH INVERTER
- PROPOSED WETLAND SETBACK
- PROPOSED SOLAR ARRAY BOUNDARY
- PROPOSED MODULE SETBACK
- PROPOSED ACCESS ROAD
- PROPOSED SECURITY FENCE
- PROPOSED LAYDOWN YARD
- PROPOSED O&M LOCATION
- PROPOSED SUBSTATION LOCATION
- PROPOSED EXISTING SUBSTATION EXPANSION LOCATION
- PROPOSED SCREENING
- PROPOSED LOW WATER CROSSING
- PROPOSED SILT FENCE
- PROPOSED CULVERT
- PROPOSED PRELIM DRAINAGE BASIN
- DL PROPOSED DISTURBANCE LIMITS
- GL PROPOSED GRADING LIMITS
- PROPOSED GRADE BREAK SWALES
- DC-XX PROPOSED DRAINAGE CROSSING
- EC-XX PROPOSED ENTRANCE CULVERT
- UMV PROPOSED UNDERGROUND COLLECTION
- OMV PROPOSED OVERHEAD COLLECTION
- PROPOSED DEER GATE LOCATION

- NOTES:**
- SEE SITE PLAN SHEETS C.401 THRU C.426 FOR LAYOUT OF ARRAY AND FACILITY FEATURES.
  - SITE PREPARATION INCLUDES BUT IS NOT LIMITED TO CLEARING/GRUBBING, MINOR GRADING, COMPACTION, MOWING OF VEGETATION, AND RESTABILIZATION OF DISTURBED AREA.
  - MINOR SURFACE SMOOTHING MAY OCCUR IN AREAS WHERE GRADING IS NOT PROPOSED FOR SAFETY OR SOLAR ARRAY INSTALLATION.
  - CONTRACTOR SHALL INSTALL ALL PERIMETER EROSION AND SEDIMENT CONTROL DEVICES PRIOR TO UPSLOPE DISTURBANCE ACTIVITIES.
  - ACCESS ROADS WILL BE CONSTRUCTED TO MATCH THE SURROUNDING EXISTING GROUND ELEVATIONS TO ALLOW THE CONTINUATION OF DRAINAGE PATTERNS. A CROWNED OR CONTINUOUS CROSS SLOPE WILL BE PROVIDED BASED ON SITE CONDITIONS.
  - OVERALL DRAINAGE PATTERNS WILL NOT BE ALTERED WITH SOLAR FACILITY.

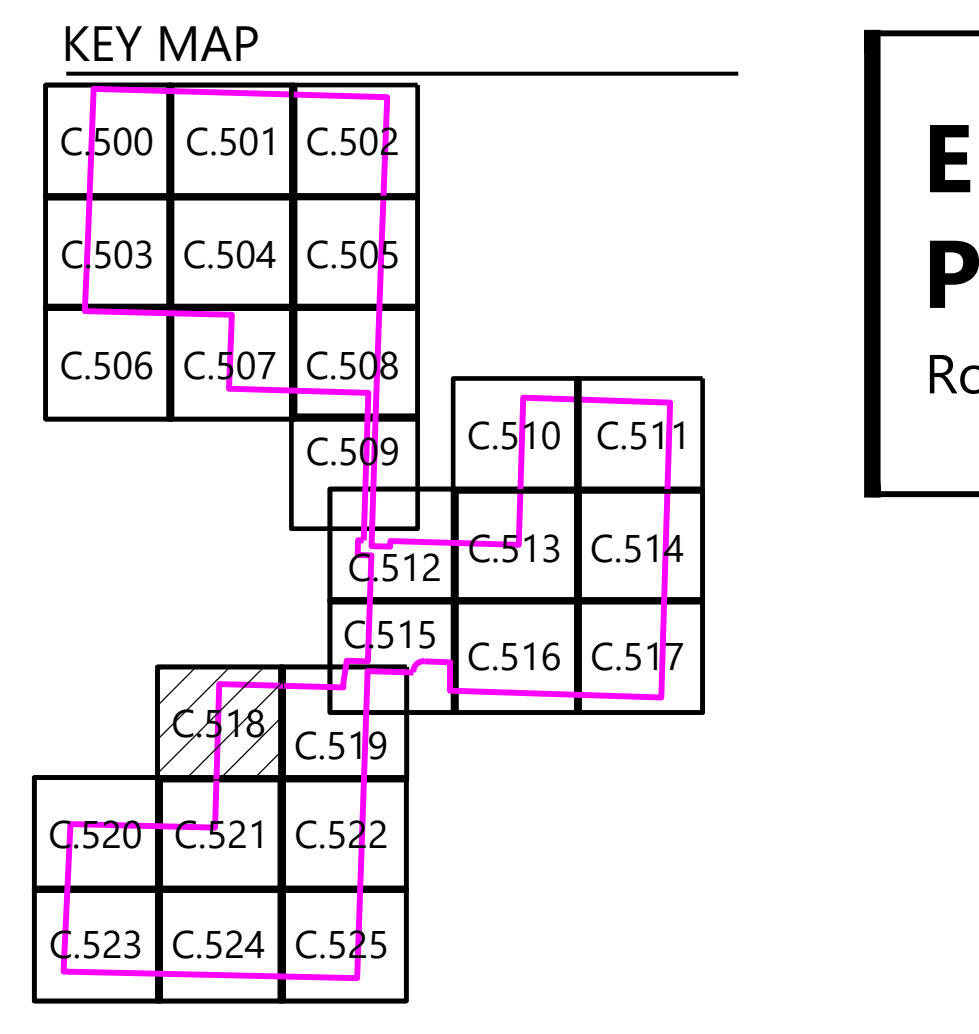

8400 Normandale Lake Blvd, Suite 1200  
 Bloomington, MN 55347

**REVISIONS:**

#	DATE	COMMENT	BY	CHK
A	05/01/2023	Permit Plans	MB	BY KA

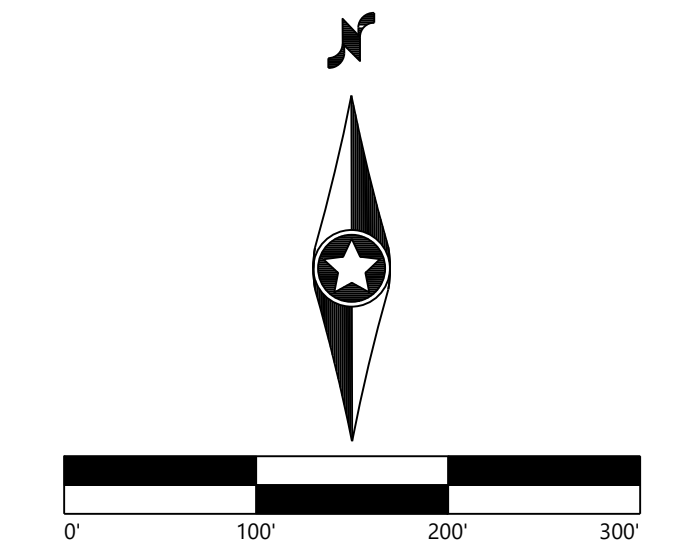

**Elk Creek Solar Project**  
 Rock County, MN

Grading and Drainage Plan - 19

**NOT FOR CONSTRUCTION**

DATE: 05/01/2023  
 SHEET: C.518 A

150015991200.dwg | C:\01\19991200.dwg | 5/1/2023 3:39 PM | AutoCAD

SEE SHEET C.422

SEE SHEET C.420

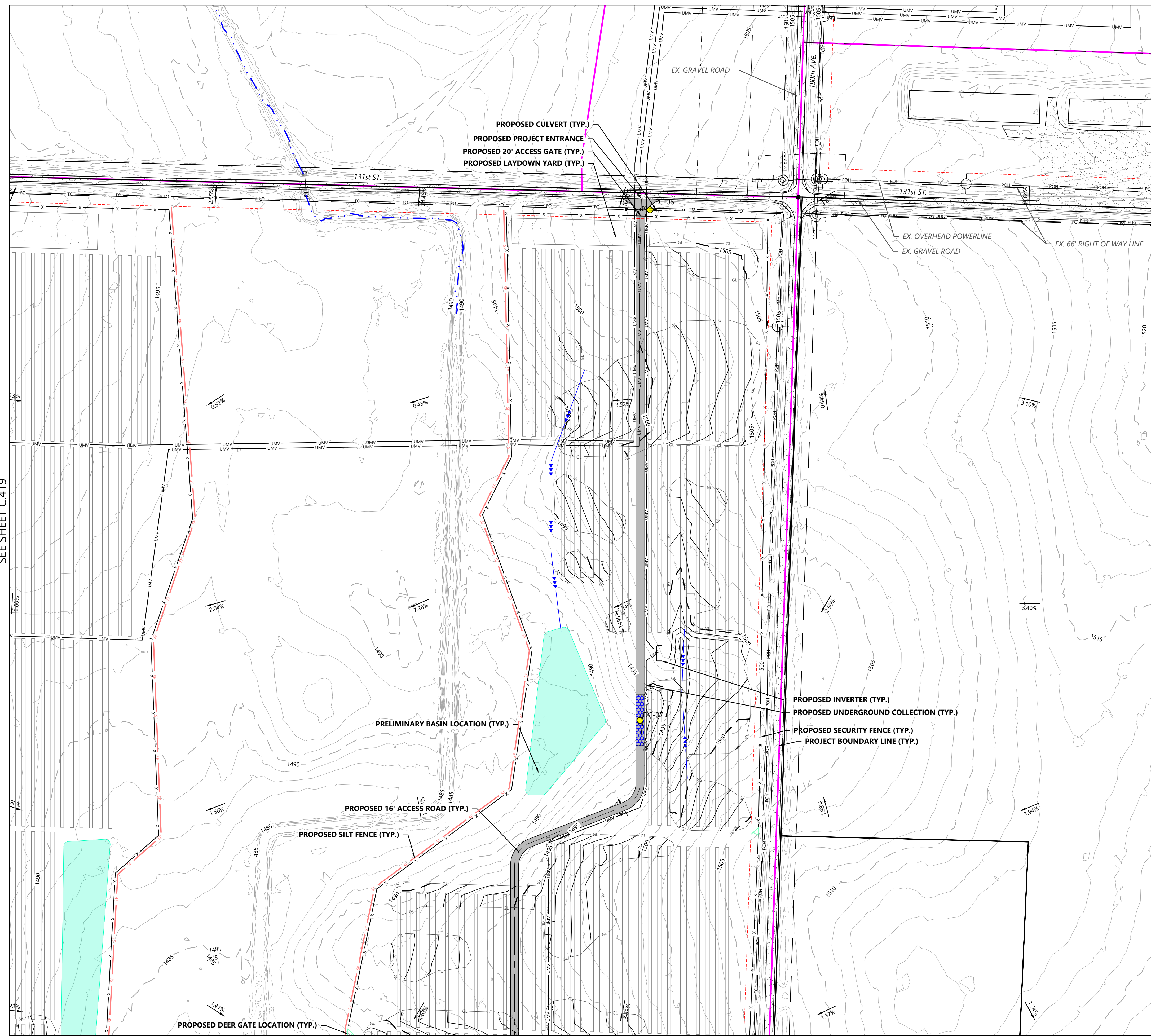

**LEGEND:**

- PROJECT BOUNDARY
- - - EX. EASEMENT LINE
- - - EX. SECTION LINE
- - - EX. PARCEL LINE
- RIGHT-OF-WAY LINES
- EX. OVERHEAD POWER
- EX. UNDERGROUND COLLECTION
- EX. FIBER OPTIC
- EX. PAVED ROAD
- EX. GRAVEL ROAD
- EX. STREAM CHANNEL
- EX. WETLAND
- EX. STRUCTURE
- EX. CULVERT
- EX. SIGN
- EX. TELEPHONE PEDESTAL
- EX. INDEX CONTOUR
- EX. INTERVAL CONTOUR
- PROPOSED INDEX CONTOUR
- PROPOSED INTERVAL CONTOUR
- PROPOSED SOLAR ARRAY WITH INVERTER
- PROPOSED WETLAND SETBACK
- PROPOSED SOLAR ARRAY BOUNDARY
- PROPOSED MODULE SETBACK
- PROPOSED ACCESS ROAD
- PROPOSED SECURITY FENCE
- PROPOSED LAYDOWN YARD
- PROPOSED O&M LOCATION
- PROPOSED SUBSTATION LOCATION
- PROPOSED EXISTING SUBSTATION EXPANSION LOCATION
- PROPOSED SCREENING
- PROPOSED LOW WATER CROSSING
- PROPOSED SILT FENCE
- PROPOSED CULVERT
- PROPOSED PRELIM DRAINAGE BASIN
- DL PROPOSED DISTURBANCE LIMITS
- GL PROPOSED GRADING LIMITS
- PROPOSED GRADE BREAK SWALES
- PROPOSED DRAINAGE CROSSING
- DC-XX PROPOSED ENTRANCE CULVERT
- EC-XX PROPOSED UNDERGROUND COLLECTION
- EX. OVERHEAD COLLECTION
- PROPOSED DEER GATE LOCATION

- NOTES:**
- SEE SITE PLAN SHEETS C.401 THRU C.426 FOR LAYOUT OF ARRAY AND FACILITY FEATURES.
  - SITE PREPARATION INCLUDES BUT IS NOT LIMITED TO CLEARING/GRUBBING, MINOR GRADING, COMPACTION, MOWING OF VEGETATION, AND RESTABILIZATION OF DISTURBED AREA.
  - MINOR SURFACE SMOOTHING MAY OCCUR IN AREAS WHERE GRADING IS NOT PROPOSED FOR SAFETY OR SOLAR ARRAY INSTALLATION.
  - CONTRACTOR SHALL INSTALL ALL PERIMETER EROSION AND SEDIMENT CONTROL DEVICES PRIOR TO UPSLOPE DISTURBANCE ACTIVITIES.
  - ACCESS ROADS WILL BE CONSTRUCTED TO MATCH THE SURROUNDING EXISTING GROUND ELEVATIONS TO ALLOW THE CONTINUATION OF DRAINAGE PATTERNS. A CROWNED OR CONTINUOUS CROSS SLOPE WILL BE PROVIDED BASED ON SITE CONDITIONS.
  - OVERALL DRAINAGE PATTERNS WILL NOT BE ALTERED WITH SOLAR FACILITY.

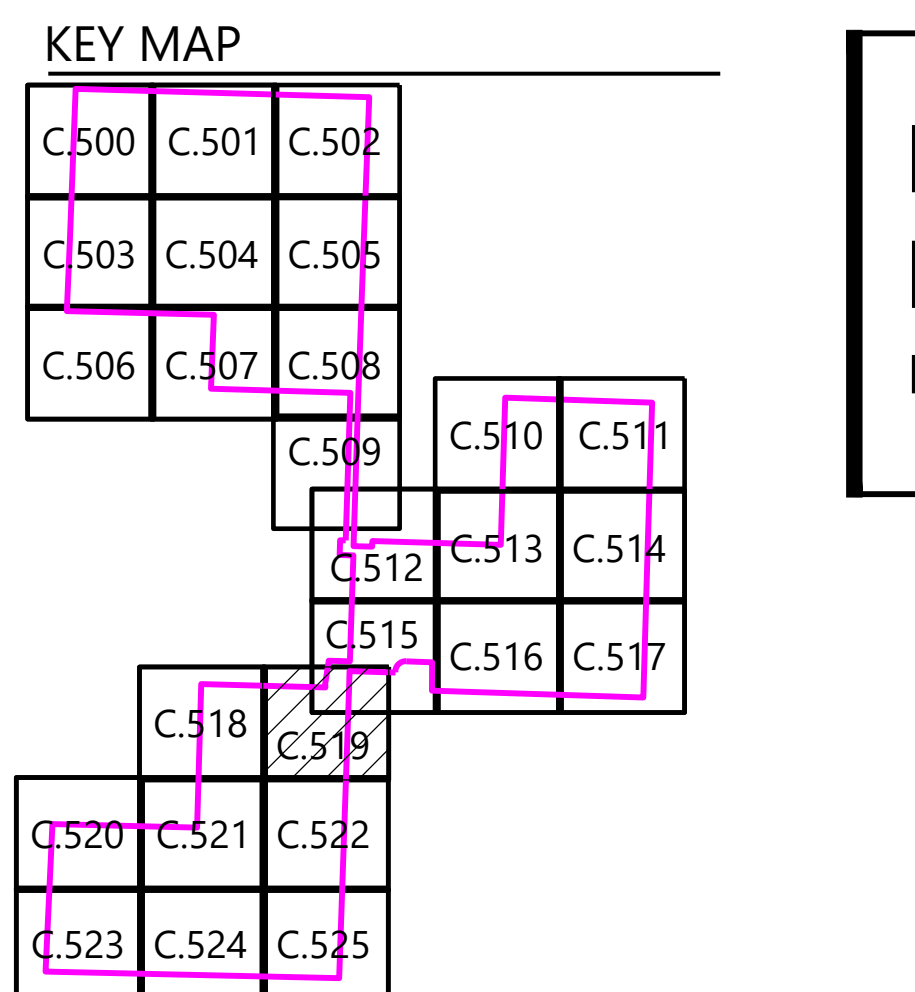

8400 Normandale Lake Blvd, Suite 1200  
 Bloomington, MN 55347

**REVISIONS:**

#	DATE	COMMENT	BY	CHK	APR
A	05/01/2023	Permit Plans	MB	BV	KA

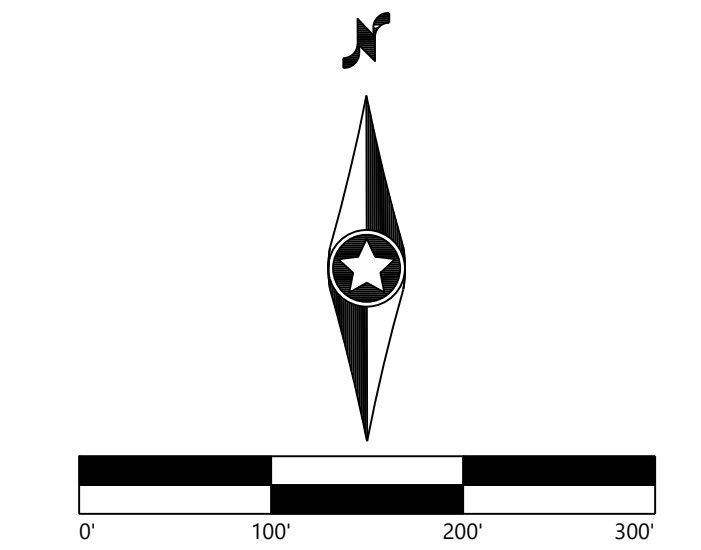

## Elk Creek Solar Project

Rock County, MN

### Grading and Drainage Plan - 20

**NOT FOR CONSTRUCTION**

DATE: 05/01/2023 REV:  
 SHEET: C.519 A

20230501 10:00 AM C:\Users\jgibson\OneDrive\Documents\Elk Creek Solar\Grading and Drainage Plan - 20.dwg 3/27/2023 3:39 PM Matt Blum

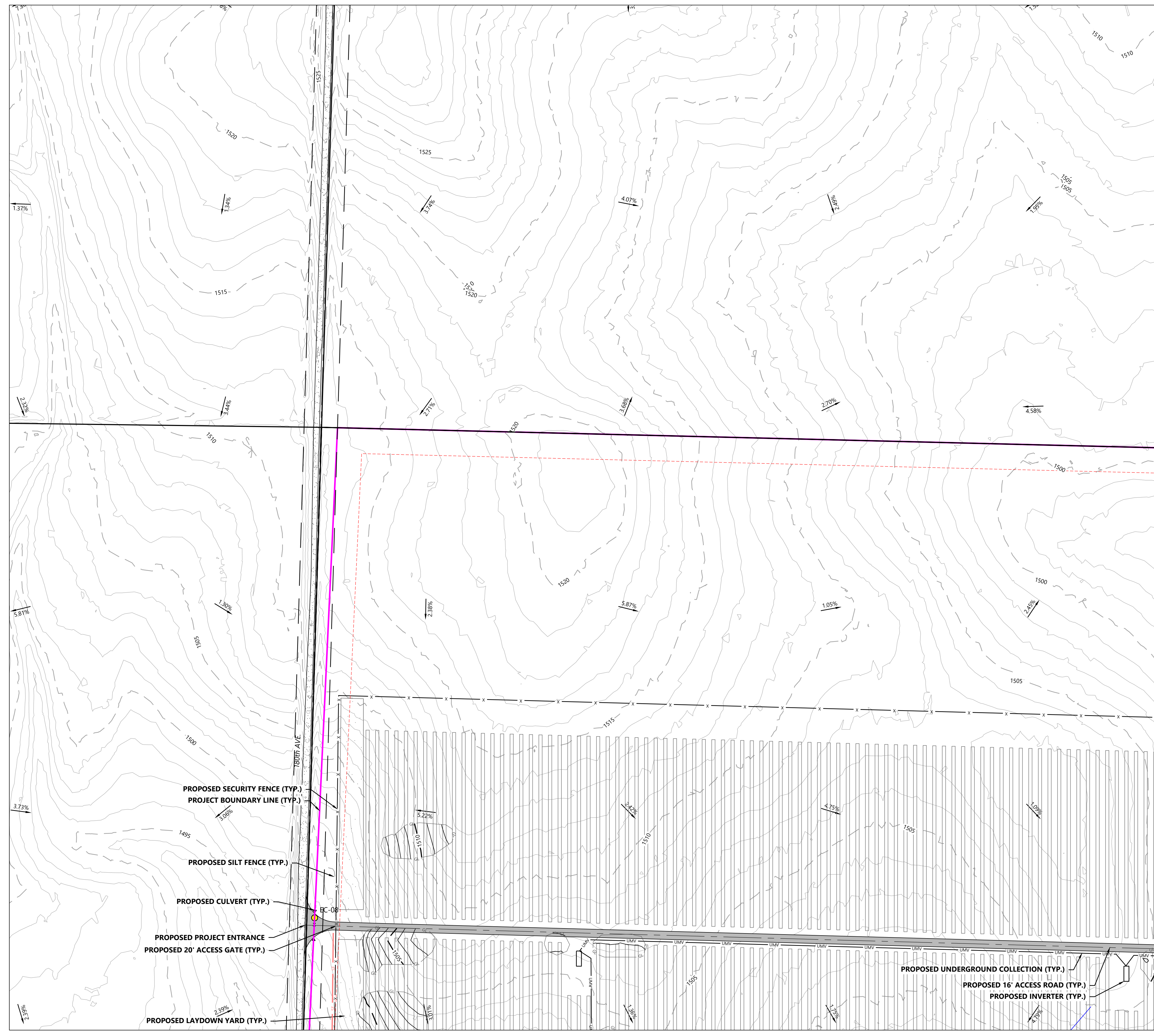

**LEGEND:**

	PROJECT BOUNDARY
	EX. EASEMENT LINE
	EX. SECTION LINE
	EX. PARCEL LINE
	RIGHT-OF-WAY LINES
	EX. OVERHEAD POWER
	EX. UNDERGROUND COLLECTION
	EX. FIBER OPTIC
	EX. PAVED ROAD
	EX. GRAVEL ROAD
	EX. STREAM CHANNEL
	EX. WETLAND
	EX. STRUCTURE
	EX. CULVERT
	EX. SIGN
	EX. TELEPHONE PEDESTAL
	EX. INDEX CONTOUR
	EX. INTERVAL CONTOUR
	PROPOSED INDEX CONTOUR
	PROPOSED INTERVAL CONTOUR
	PROPOSED SOLAR ARRAY WITH INVERTER
	PROPOSED WETLAND SETBACK
	PROPOSED SOLAR ARRAY BOUNDARY
	PROPOSED MODULE SETBACK
	PROPOSED ACCESS ROAD
	PROPOSED SECURITY FENCE
	PROPOSED LAYDOWN YARD
	PROPOSED O&M LOCATION
	PROPOSED SUBSTATION LOCATION
	PROPOSED EXISTING SUBSTATION EXPANSION LOCATION
	PROPOSED SCREENING
	PROPOSED LOW WATER CROSSING
	PROPOSED SILT FENCE
	PROPOSED CULVERT
	PROPOSED PRELIM DRAINAGE BASIN
	PROPOSED DISTURBANCE LIMITS
	PROPOSED GRADING LIMITS
	PROPOSED GRADE BREAK SWALES
	PROPOSED DRAINAGE CROSSING
	PROPOSED ENTRANCE CULVERT
	PROPOSED UNDERGROUND COLLECTION
	PROPOSED OVERHEAD COLLECTION
	PROPOSED DEER GATE LOCATION

- NOTES:**
- SEE SITE PLAN SHEETS C.401 THRU C.426 FOR LAYOUT OF ARRAY AND FACILITY FEATURES.
  - SITE PREPARATION INCLUDES BUT IS NOT LIMITED TO CLEARING/GRUBBING, MINOR GRADING, COMPACTION, MOWING OF VEGETATION, AND RESTABILIZATION OF DISTURBED AREA.
  - MINOR SURFACE SMOOTHING MAY OCCUR IN AREAS WHERE GRADING IS NOT PROPOSED FOR SAFETY OR SOLAR ARRAY INSTALLATION.
  - CONTRACTOR SHALL INSTALL ALL PERIMETER EROSION AND SEDIMENT CONTROL DEVICES PRIOR TO UPSLOPE DISTURBANCE ACTIVITIES.
  - ACCESS ROADS WILL BE CONSTRUCTED TO MATCH THE SURROUNDING EXISTING GROUND ELEVATIONS TO ALLOW THE CONTINUATION OF DRAINAGE PATTERNS. A CROWNED OR CONTINUOUS CROSS SLOPE WILL BE PROVIDED BASED ON SITE CONDITIONS.
  - OVERALL DRAINAGE PATTERNS WILL NOT BE ALTERED WITH SOLAR FACILITY.

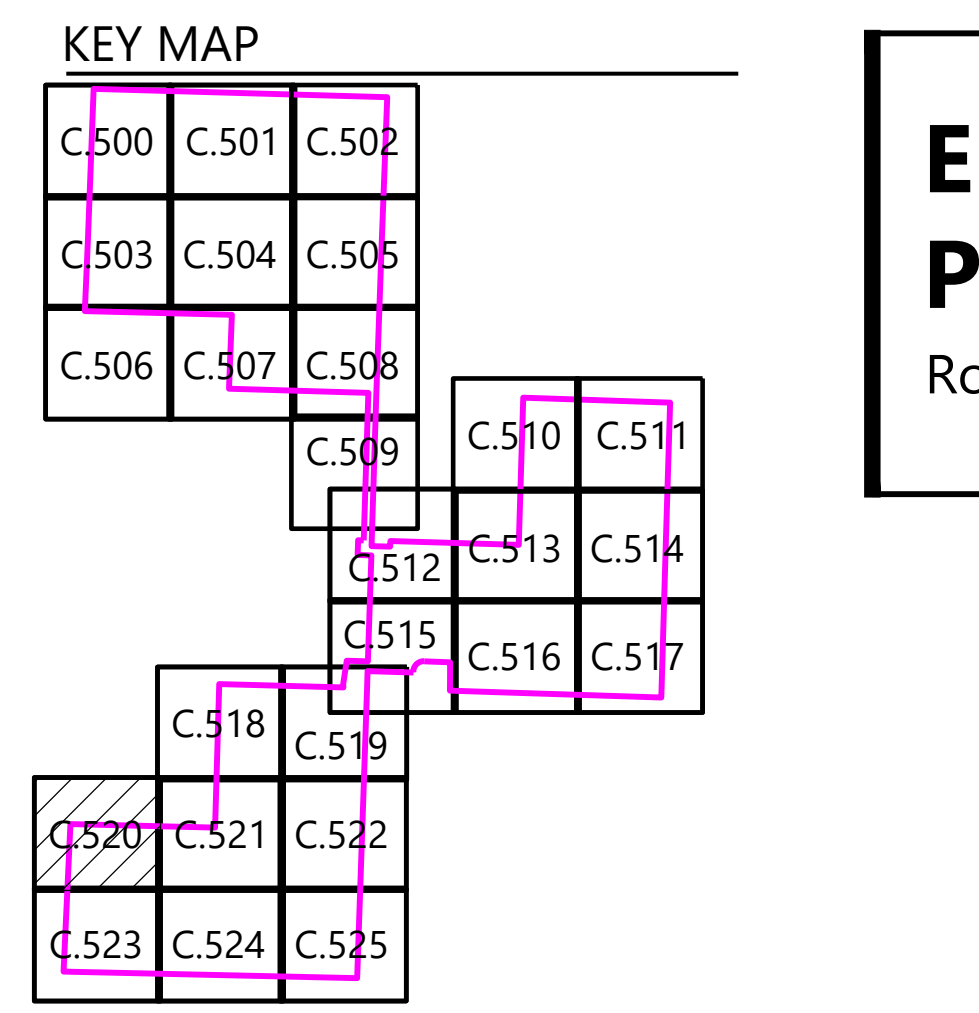

REVISIONS:

#	DATE	COMMENT	BY	CHK
A	05/01/2023	Permit Plans	MB	BV KA

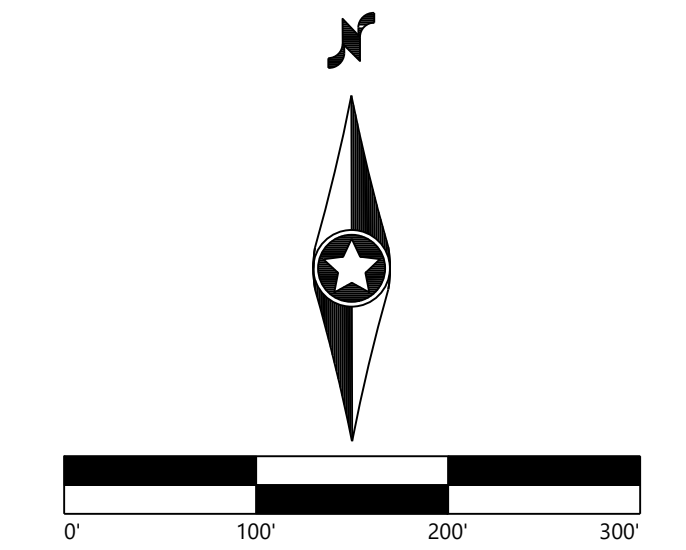

**Elk Creek Solar Project**  
 Rock County, MN

**Grading and Drainage Plan - 21**

**NOT FOR CONSTRUCTION**

DATE: 05/01/2023 REV:  
 SHEET: C.520 A

SEE SHEET C.424

SEE SHEET C.422

5/20/2023 10:20 AM C:\Users\jgibson\OneDrive\Documents\20230501\Elk Creek Solar Project\Grading and Drainage Plan - 21.dwg

SEE SHEET C.419

SEE SHEET C.425

SEE SHEET C.421

SEE SHEET C.423



**LEGEND:**

- PROJECT BOUNDARY
- - - EX. EASEMENT LINE
- - - EX. SECTION LINE
- EX. PARCEL LINE
- RIGHT-OF-WAY LINES
- EX. OVERHEAD POWER
- EX. UNDERGROUND COLLECTION
- EX. FIBER OPTIC
- EX. PAVED ROAD
- EX. GRAVEL ROAD
- EX. STREAM CHANNEL
- EX. WETLAND
- EX. STRUCTURE
- EX. CULVERT
- EX. SIGN
- EX. TELEPHONE PEDESTAL
- EX. INDEX CONTOUR
- EX. INTERVAL CONTOUR
- PROPOSED INDEX CONTOUR
- PROPOSED INTERVAL CONTOUR
- PROPOSED SOLAR ARRAY WITH INVERTER
- PROPOSED WETLAND SETBACK
- PROPOSED SOLAR ARRAY BOUNDARY
- PROPOSED MODULE SETBACK
- PROPOSED ACCESS ROAD
- PROPOSED SECURITY FENCE
- PROPOSED LAYDOWN YARD
- PROPOSED O&M LOCATION
- PROPOSED SUBSTATION LOCATION
- PROPOSED EXISTING SUBSTATION EXPANSION LOCATION
- PROPOSED SCREENING
- PROPOSED LOW WATER CROSSING
- PROPOSED SILT FENCE
- PROPOSED CULVERT
- PROPOSED PRELIM DRAINAGE BASIN
- PROPOSED DISTURBANCE LIMITS
- PROPOSED GRADING LIMITS
- PROPOSED GRADE BREAK SWALES
- PROPOSED DRAINAGE CROSSING
- PROPOSED ENTRANCE CULVERT
- PROPOSED UNDERGROUND COLLECTION
- PROPOSED OVERHEAD COLLECTION
- PROPOSED DEER GATE LOCATION

**NOTES:**

- SEE SITE PLAN SHEETS C.401 THRU C.426 FOR LAYOUT OF ARRAY AND FACILITY FEATURES.
- SITE PREPARATION INCLUDES BUT IS NOT LIMITED TO CLEARING/GRUBBING, MINOR GRADING, COMPACTION, MOWING OF VEGETATION, AND RESTABILIZATION OF DISTURBED AREA.
- MINOR SURFACE SMOOTHING MAY OCCUR IN AREAS WHERE GRADING IS NOT PROPOSED FOR SAFETY OR SOLAR ARRAY INSTALLATION.
- CONTRACTOR SHALL INSTALL ALL PERIMETER EROSION AND SEDIMENT CONTROL DEVICES PRIOR TO UPSLOPE DISTURBANCE ACTIVITIES.
- ACCESS ROADS WILL BE CONSTRUCTED TO MATCH THE SURROUNDING EXISTING GROUND ELEVATIONS TO ALLOW THE CONTINUATION OF DRAINAGE PATTERNS. A CROWNED OR CONTINUOUS CROSS SLOPE WILL BE PROVIDED BASED ON SITE CONDITIONS.
- OVERALL DRAINAGE PATTERNS WILL NOT BE ALTERED WITH SOLAR FACILITY.

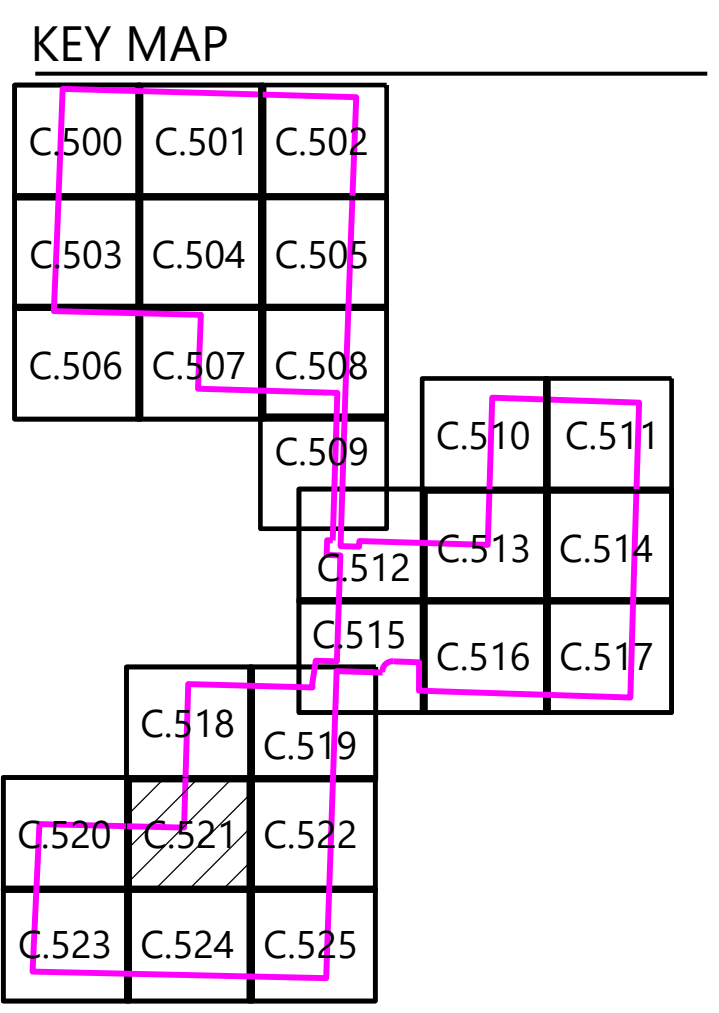

**Westwood**

Phone (952) 937-5150 12701 Whitewater Drive, Suite #300  
 Fax (952) 937-5822 Minnetonka, MN 55343  
 TollFree (888) 937-5150 westwoodsps.com  
 Westwood Professional Services, Inc.

PREPARED FOR:

**nationalgrid  
renewables**

8400 Normandale Lake Blvd, Suite 1200  
 Bloomington, MN 55347

REVISIONS:

#	DATE	COMMENT	BY	CHK	APR
A	05/01/2023	Permit Plans	MB	BV	KA

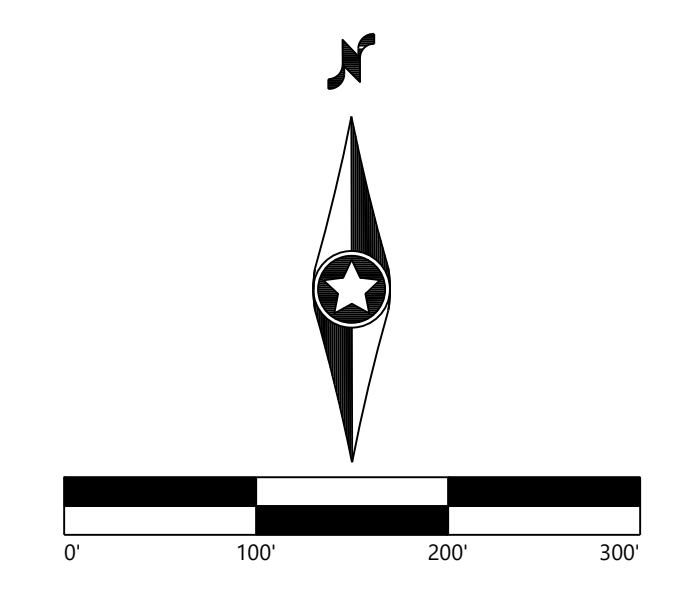

**Elk Creek Solar  
Project**

Rock County, MN

Grading and Drainage  
Plan - 22

**NOT FOR CONSTRUCTION**

DATE: 05/01/2023 REV:  
 SHEET: C.521 A

20230501 10:00 AM C:\Users\jgibson\OneDrive\Documents\20230501 10:00 AM Westwood

SEE SHEET C.420



SEE SHEET C.422

SEE SHEET C.426

- LEGEND:**
- PROJECT BOUNDARY
  - - - EX. EASEMENT LINE
  - - - EX. SECTION LINE
  - EX. PARCEL LINE
  - RIGHT-OF-WAY LINES
  - OPH EX. OVERHEAD POWER
  - UG EX. UNDERGROUND COLLECTION
  - FO EX. FIBER OPTIC
  - EX. PAVED ROAD
  - EX. GRAVEL ROAD
  - EX. STREAM CHANNEL
  - EX. WETLAND
  - EX. STRUCTURE
  - EX. CULVERT
  - EX. SIGN
  - EX. TELEPHONE PEDESTAL
  - EX. INDEX CONTOUR
  - EX. INTERVAL CONTOUR
  - PROPOSED INDEX CONTOUR
  - PROPOSED INTERVAL CONTOUR
  - PROPOSED SOLAR ARRAY WITH INVERTER
  - PROPOSED WETLAND SETBACK
  - PROPOSED SOLAR ARRAY BOUNDARY
  - PROPOSED MODULE SETBACK
  - PROPOSED ACCESS ROAD
  - PROPOSED SECURITY FENCE
  - PROPOSED LAYDOWN YARD
  - PROPOSED O&M LOCATION
  - PROPOSED SUBSTATION LOCATION
  - PROPOSED EXISTING SUBSTATION EXPANSION LOCATION
  - PROPOSED SCREENING
  - PROPOSED LOW WATER CROSSING
  - PROPOSED SILT FENCE
  - PROPOSED CULVERT
  - PROPOSED PRELIM DRAINAGE BASIN
  - DL PROPOSED DISTURBANCE LIMITS
  - GL PROPOSED GRADING LIMITS
  - PROPOSED GRADE BREAK SWALES
  - PROPOSED DRAINAGE CROSSING
  - DC-XX PROPOSED ENTRANCE CULVERT
  - EC-XX PROPOSED UNDERGROUND COLLECTION
  - OMV PROPOSED OVERHEAD COLLECTION
  - PROPOSED DEER GATE LOCATION

- NOTES:**
- SEE SITE PLAN SHEETS C.401 THRU C.426 FOR LAYOUT OF ARRAY AND FACILITY FEATURES.
  - SITE PREPARATION INCLUDES BUT IS NOT LIMITED TO CLEARING/GRUBBING, MINOR GRADING, COMPACTION, MOWING OF VEGETATION, AND RESTABILIZATION OF DISTURBED AREA.
  - MINOR SURFACE SMOOTHING MAY OCCUR IN AREAS WHERE GRADING IS NOT PROPOSED FOR SAFETY OR SOLAR ARRAY INSTALLATION.
  - CONTRACTOR SHALL INSTALL ALL PERIMETER EROSION AND SEDIMENT CONTROL DEVICES PRIOR TO UPSLOPE DISTURBANCE ACTIVITIES.
  - ACCESS ROADS WILL BE CONSTRUCTED TO MATCH THE SURROUNDING EXISTING GROUND ELEVATIONS TO ALLOW THE CONTINUATION OF DRAINAGE PATTERNS. A CROWNED OR CONTINUOUS CROSS SLOPE WILL BE PROVIDED BASED ON SITE CONDITIONS.
  - OVERALL DRAINAGE PATTERNS WILL NOT BE ALTERED WITH SOLAR FACILITY.

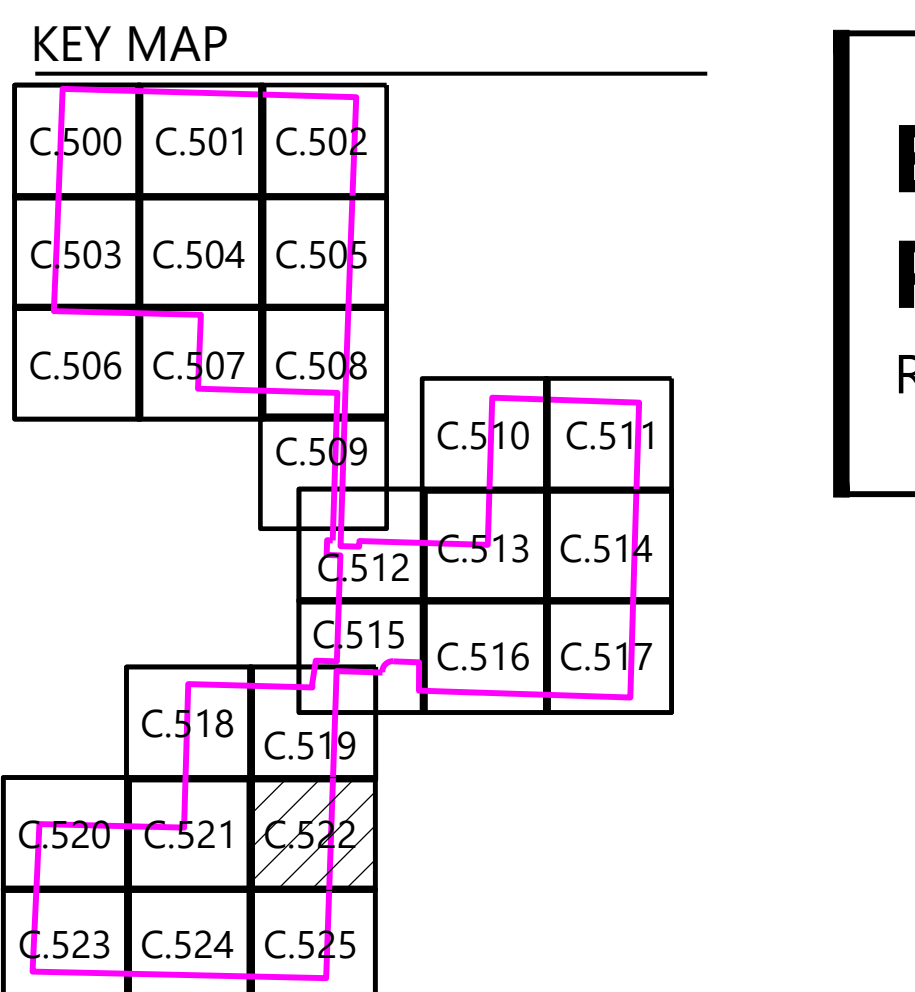

Phone (952) 937-5150 12701 Whitewater Drive, Suite #300  
 Fax (952) 937-5822 Minnetonka, MN 55343  
 TollFree (888) 937-5150 westwoodps.com  
 Westwood Professional Services, Inc.



8400 Normandale Lake Blvd, Suite 1200  
 Bloomington, MN 55347

**REVISIONS:**

#	DATE	COMMENT	BY	CHK	APR
A	05/01/2023	Permit Plans	MB	BV	KA

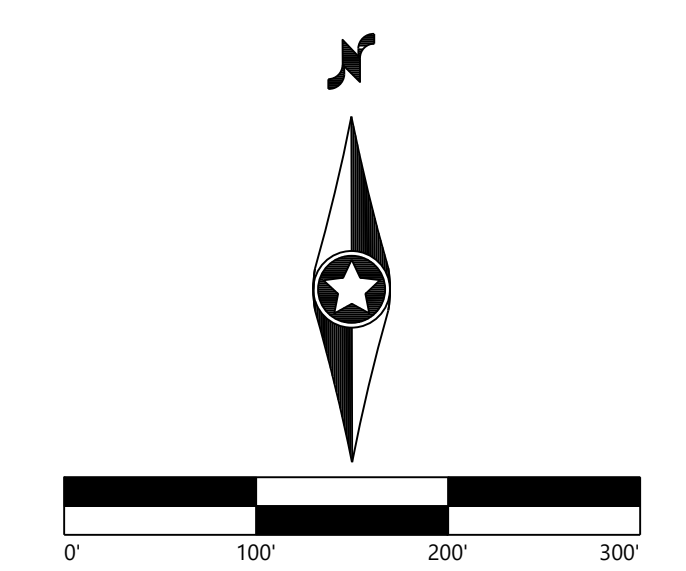

# Elk Creek Solar Project

Rock County, MN

## Grading and Drainage Plan - 23

**NOT FOR CONSTRUCTION**

DATE: 05/01/2023 REV:  
 SHEET: C.522 A

05/01/2023 10:00 AM C:\Users\jgallagher\OneDrive\Documents\Elk Creek Solar\Grading and Drainage Plan - 23.dwg (3/2/2023 10:00 AM)

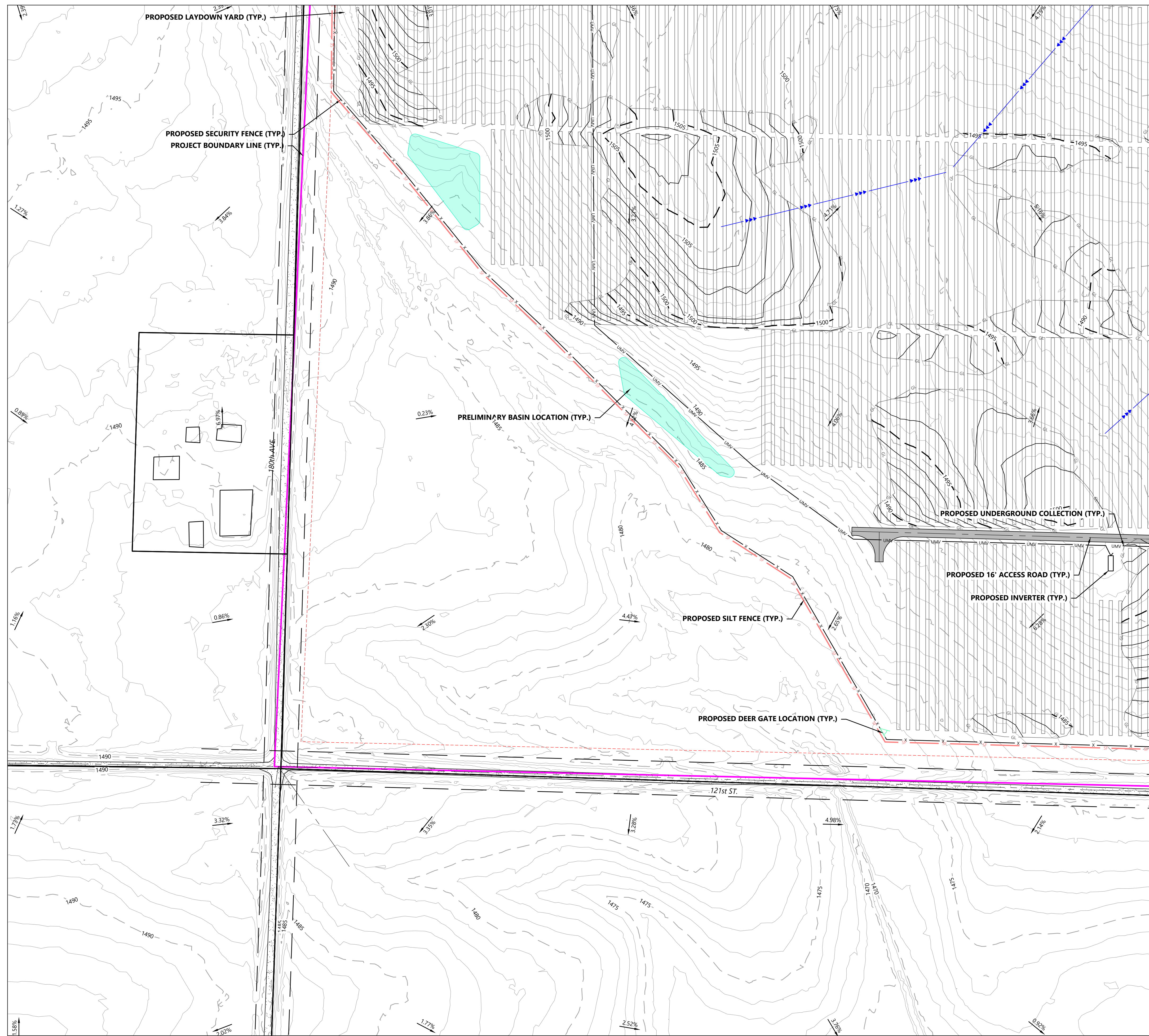

**LEGEND:**

	PROJECT BOUNDARY
	EX. EASEMENT LINE
	EX. SECTION LINE
	EX. PARCEL LINE
	RIGHT-OF-WAY LINES
	EX. OVERHEAD POWER
	EX. UNDERGROUND COLLECTION
	EX. FIBER OPTIC
	EX. PAVED ROAD
	EX. GRAVEL ROAD
	EX. STREAM CHANNEL
	EX. WETLAND
	EX. STRUCTURE
	EX. CULVERT
	EX. SIGN
	EX. TELEPHONE PEDESTAL
	EX. INDEX CONTOUR
	EX. INTERVAL CONTOUR
	PROPOSED INDEX CONTOUR
	PROPOSED INTERVAL CONTOUR
	PROPOSED SOLAR ARRAY WITH INVERTER
	PROPOSED WETLAND SETBACK
	PROPOSED SOLAR ARRAY BOUNDARY
	PROPOSED MODULE SETBACK
	PROPOSED ACCESS ROAD
	PROPOSED SECURITY FENCE
	PROPOSED LAYDOWN YARD
	PROPOSED O&M LOCATION
	PROPOSED SUBSTATION LOCATION
	PROPOSED EXISTING SUBSTATION EXPANSION LOCATION
	PROPOSED SCREENING
	PROPOSED LOW WATER CROSSING
	PROPOSED SILT FENCE
	PROPOSED CULVERT
	PROPOSED PRELIM DRAINAGE BASIN
	PROPOSED DISTURBANCE LIMITS
	PROPOSED GRADING LIMITS
	PROPOSED GRADE BREAK SWALES
	PROPOSED DRAINAGE CROSSING
	PROPOSED ENTRANCE CULVERT
	PROPOSED UNDERGROUND COLLECTION
	PROPOSED OVERHEAD COLLECTION
	PROPOSED DEER GATE LOCATION

- NOTES:**
- SEE SITE PLAN SHEETS C.401 THRU C.426 FOR LAYOUT OF ARRAY AND FACILITY FEATURES.
  - SITE PREPARATION INCLUDES BUT IS NOT LIMITED TO CLEARING/GRUBBING, MINOR GRADING, COMPACTION, MOWING OF VEGETATION, AND RESTABILIZATION OF DISTURBED AREA.
  - MINOR SURFACE SMOOTHING MAY OCCUR IN AREAS WHERE GRADING IS NOT PROPOSED FOR SAFETY OR SOLAR ARRAY INSTALLATION.
  - CONTRACTOR SHALL INSTALL ALL PERIMETER EROSION AND SEDIMENT CONTROL DEVICES PRIOR TO UPSLOPE DISTURBANCE ACTIVITIES.
  - ACCESS ROADS WILL BE CONSTRUCTED TO MATCH THE SURROUNDING EXISTING GROUND ELEVATIONS TO ALLOW THE CONTINUATION OF DRAINAGE PATTERNS. A CROWNED OR CONTINUOUS CROSS SLOPE WILL BE PROVIDED BASED ON SITE CONDITIONS.
  - OVERALL DRAINAGE PATTERNS WILL NOT BE ALTERED WITH SOLAR FACILITY.

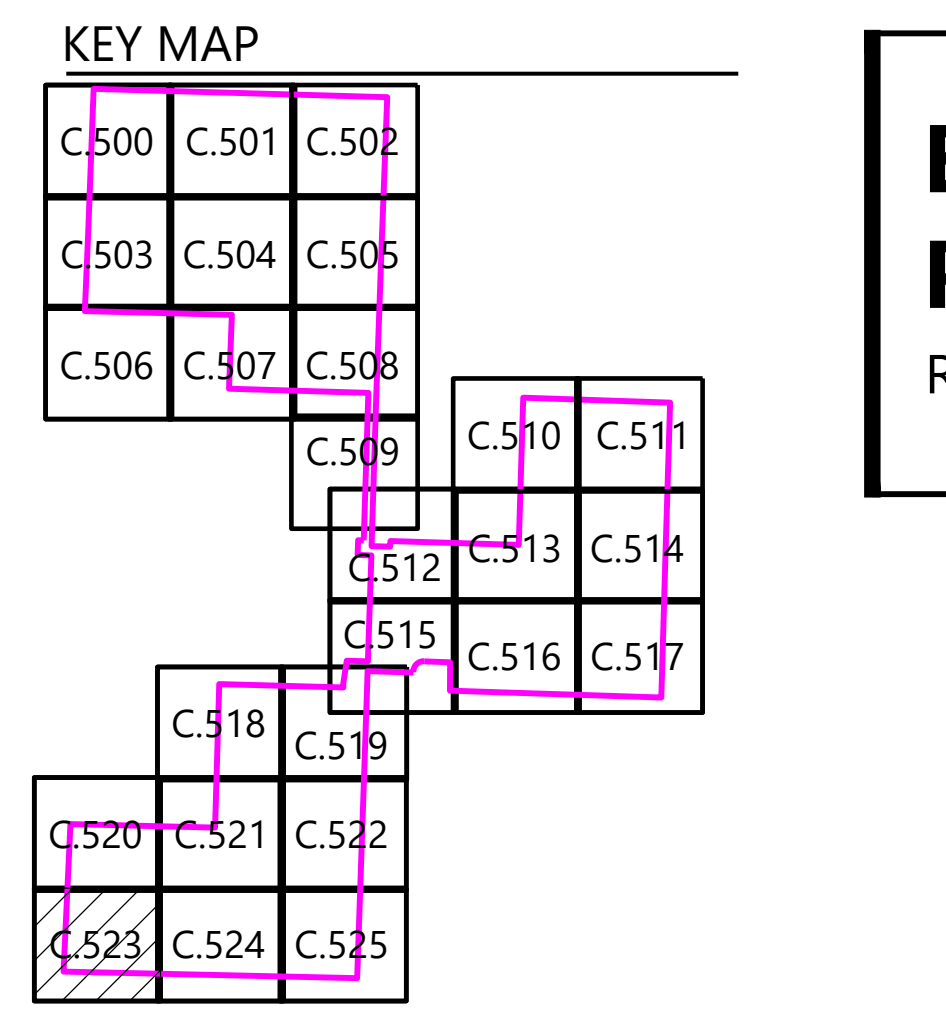

**REVISIONS:**

#	DATE	COMMENT	BY	CHK
A	05/01/2023	Permit Plans	MB	BV KA

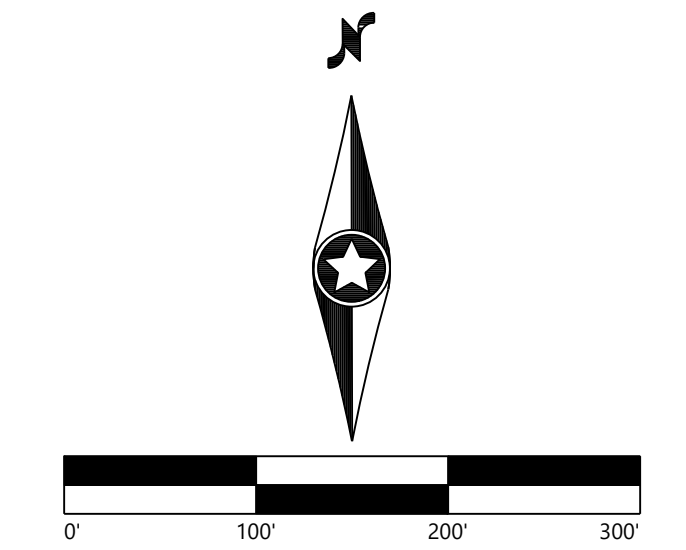

**Elk Creek Solar Project**  
 Rock County, MN

Grading and Drainage  
 Plan - 24

NOT FOR CONSTRUCTION

DATE: 05/01/2023 REV:  
 SHEET: C.523 A

20230501 10:00 AM C:\Users\jgibson\OneDrive\Documents\Elk Creek Solar\Grading and Drainage\Grading and Drainage Plan - 24.dwg 3/27/2023 10:32 AM Matt Blum

SEE SHEET C.422

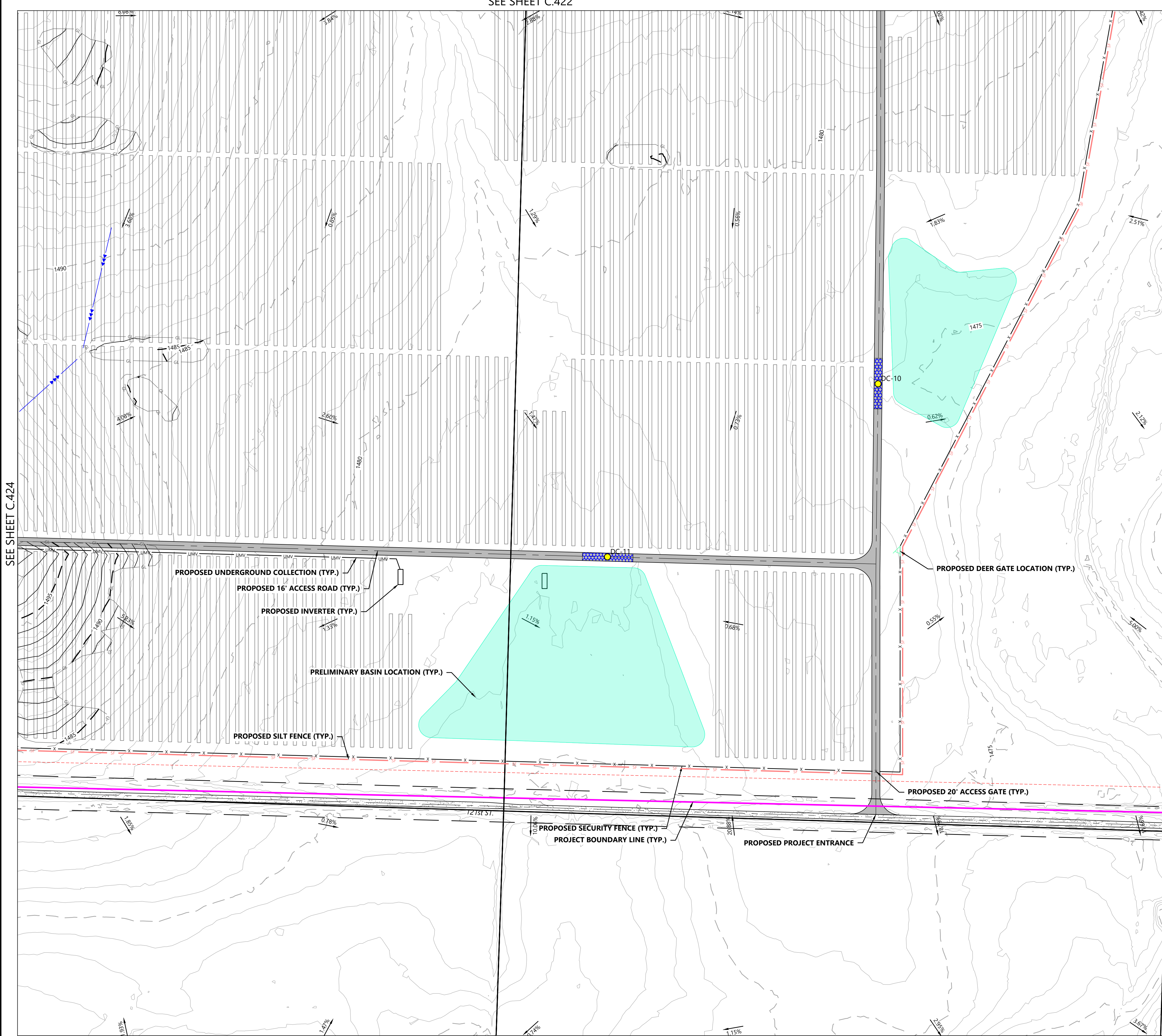

- LEGEND:**
- PROJECT BOUNDARY
  - - - EX. EASEMENT LINE
  - - - EX. SECTION LINE
  - EX. PARCEL LINE
  - RIGHT-OF-WAY LINES
  - EX. OVERHEAD POWER
  - EX. UNDERGROUND COLLECTION
  - EX. FIBER OPTIC
  - EX. PAVED ROAD
  - EX. GRAVEL ROAD
  - EX. STREAM CHANNEL
  - EX. WETLAND
  - EX. STRUCTURE
  - EX. CULVERT
  - EX. SIGN
  - EX. TELEPHONE PEDESTAL
  - EX. INDEX CONTOUR
  - EX. INTERVAL CONTOUR
  - PROPOSED INDEX CONTOUR
  - PROPOSED INTERVAL CONTOUR
  - PROPOSED SOLAR ARRAY WITH INVERTER
  - PROPOSED WETLAND SETBACK
  - PROPOSED SOLAR ARRAY BOUNDARY
  - PROPOSED MODULE SETBACK
  - PROPOSED ACCESS ROAD
  - PROPOSED SECURITY FENCE
  - PROPOSED LAYDOWN YARD
  - PROPOSED O&M LOCATION
  - PROPOSED SUBSTATION LOCATION
  - PROPOSED EXISTING SUBSTATION EXPANSION LOCATION
  - PROPOSED SCREENING
  - PROPOSED LOW WATER CROSSING
  - PROPOSED SILT FENCE
  - PROPOSED CULVERT
  - PROPOSED PRELIM DRAINAGE BASIN
  - DL --- PROPOSED DISTURBANCE LIMITS
  - GL --- PROPOSED GRADING LIMITS
  - PROPOSED GRADE BREAK SWALES
  - DC-XX --- PROPOSED DRAINAGE CROSSING
  - EC-XX --- PROPOSED ENTRANCE CULVERT
  - UMW --- PROPOSED UNDERGROUND COLLECTION
  - OMV --- PROPOSED OVERHEAD COLLECTION
  - PROPOSED DEER GATE LOCATION

- NOTES:**
1. SEE SITE PLAN SHEETS C.401 THRU C.426 FOR LAYOUT OF ARRAY AND FACILITY FEATURES.
  2. SITE PREPARATION INCLUDES BUT IS NOT LIMITED TO CLEARING/GRUBBING, MINOR GRADING, COMPACTION, MOWING OF VEGETATION, AND RESTABILIZATION OF DISTURBED AREA.
  3. MINOR SURFACE SMOOTHING MAY OCCUR IN AREAS WHERE GRADING IS NOT PROPOSED FOR SAFETY OR SOLAR ARRAY INSTALLATION.
  4. CONTRACTOR SHALL INSTALL ALL PERIMETER EROSION AND SEDIMENT CONTROL DEVICES PRIOR TO UPSLOPE DISTURBANCE ACTIVITIES.
  5. ACCESS ROADS WILL BE CONSTRUCTED TO MATCH THE SURROUNDING EXISTING GROUND ELEVATIONS TO ALLOW THE CONTINUATION OF DRAINAGE PATTERNS. A CROWNED OR CONTINUOUS CROSS SLOPE WILL BE PROVIDED BASED ON SITE CONDITIONS.
  6. OVERALL DRAINAGE PATTERNS WILL NOT BE ALTERED WITH SOLAR FACILITY.

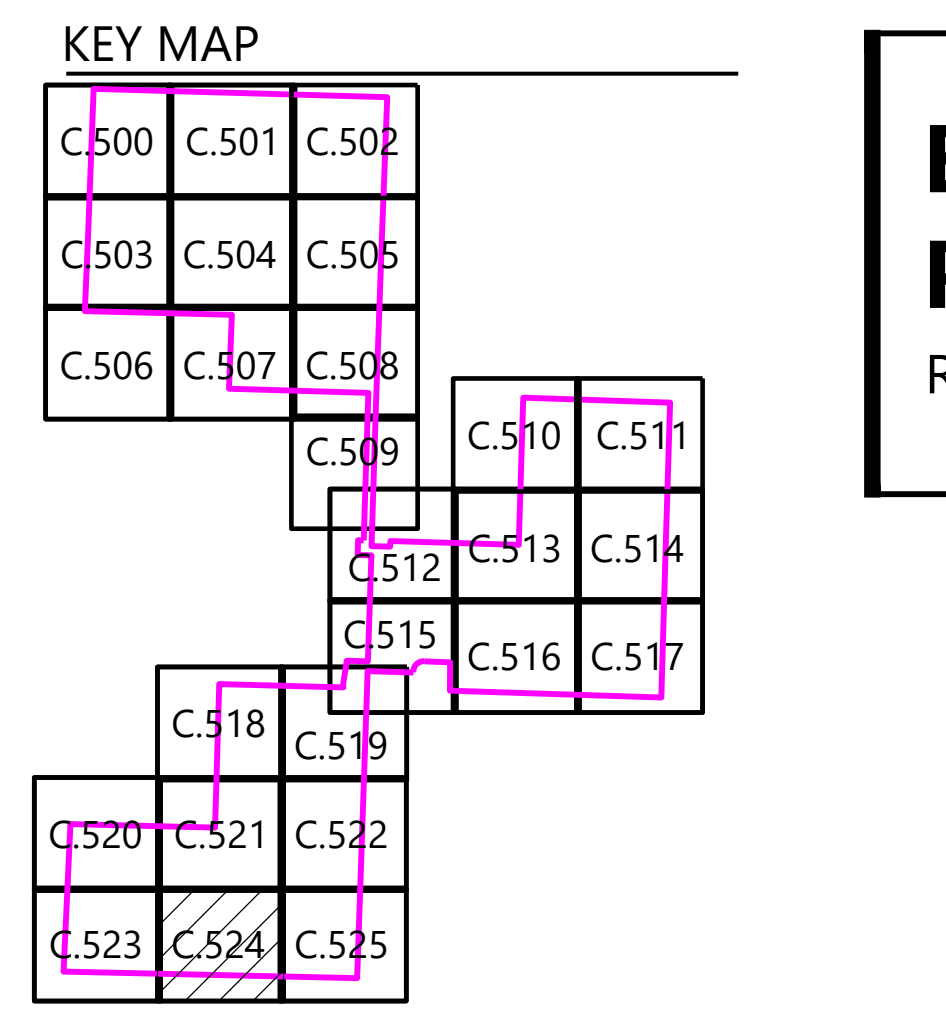

**Westwood**  
 Phone (952) 937-5150 12701 Whitewater Drive, Suite #300  
 Fax (952) 937-5822 Minnetonka, MN 55343  
 TollFree (888) 937-5150 westwoodps.com  
 Westwood Professional Services, Inc.

PREPARED FOR:

8400 Normandale Lake Blvd, Suite 1200  
 Bloomington, MN 55347

**REVISIONS:**

#	DATE	COMMENT	BY	CHK	APR
A	05/01/2023	Permit Plans	MB	BV	KA

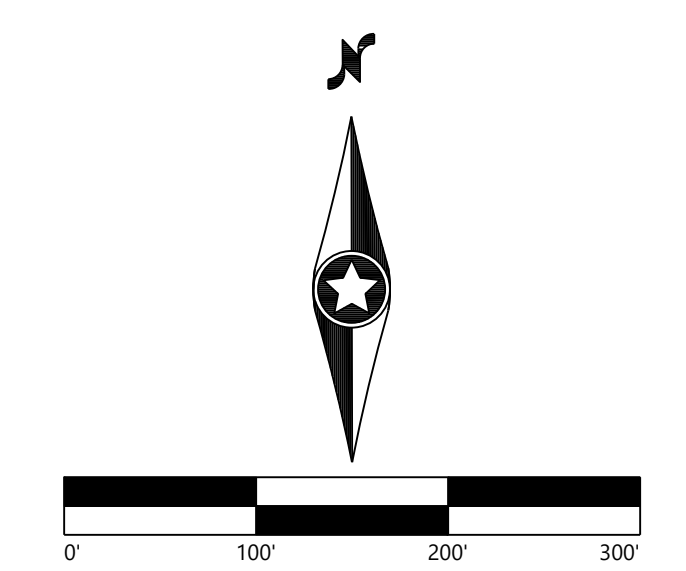

**Elk Creek Solar Project**  
 Rock County, MN

Grading and Drainage Plan - 25

NOT FOR CONSTRUCTION

DATE: 05/01/2023 REV:  
 SHEET: C.524 A

SEE SHEET C.424

SEE SHEET C.426

20230501 10:00 AM C:\Users\jgibson\OneDrive\Documents\Elk Creek Solar\Grading and Drainage Plan - 25.dwg 3/27/2023 10:32 AM Matt Blum



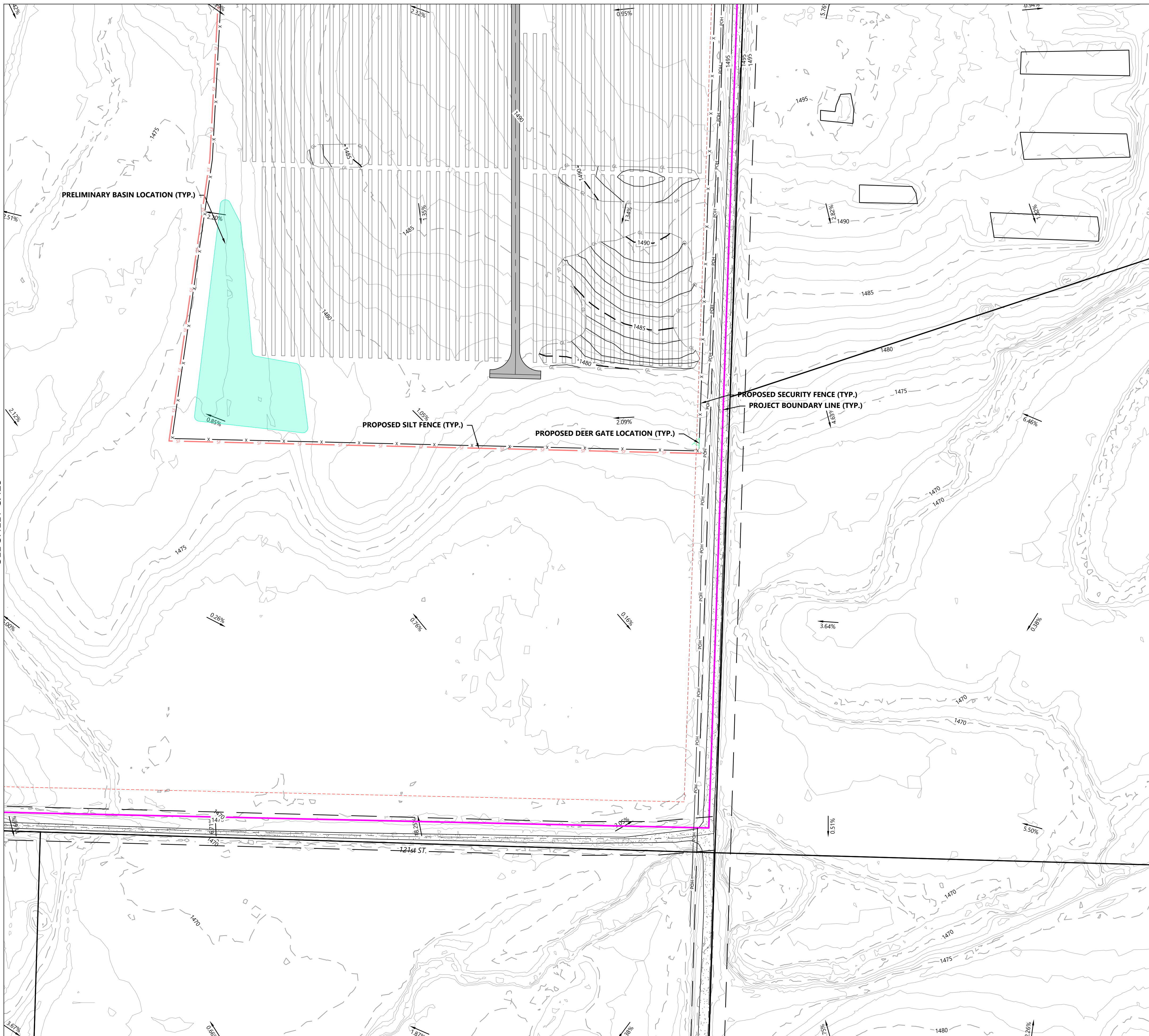

**LEGEND:**

- PROJECT BOUNDARY
- - - EX. EASEMENT LINE
- - - EX. SECTION LINE
- EX. PARCEL LINE
- RIGHT-OF-WAY LINES
- EX. OVERHEAD POWER
- EX. UNDERGROUND COLLECTION
- EX. FIBER OPTIC
- EX. PAVED ROAD
- EX. GRAVEL ROAD
- EX. STREAM CHANNEL
- EX. WETLAND
- EX. STRUCTURE
- EX. CULVERT
- EX. SIGN
- EX. TELEPHONE PEDESTAL
- EX. INDEX CONTOUR
- EX. INTERVAL CONTOUR
- PROPOSED INDEX CONTOUR
- PROPOSED INTERVAL CONTOUR
- PROPOSED SOLAR ARRAY WITH INVERTER
- PROPOSED WETLAND SETBACK
- PROPOSED SOLAR ARRAY BOUNDARY
- PROPOSED MODULE SETBACK
- PROPOSED ACCESS ROAD
- PROPOSED SECURITY FENCE
- PROPOSED LAYDOWN YARD
- PROPOSED O&M LOCATION
- PROPOSED SUBSTATION LOCATION
- PROPOSED EXISTING SUBSTATION EXPANSION LOCATION
- PROPOSED SCREENING
- PROPOSED LOW WATER CROSSING
- PROPOSED SILT FENCE
- PROPOSED CULVERT
- PROPOSED PRELIM DRAINAGE BASIN
- PROPOSED DISTURBANCE LIMITS
- PROPOSED GRADING LIMITS
- PROPOSED GRADE BREAK SWALES
- PROPOSED DRAINAGE CROSSING
- PROPOSED ENTRANCE CULVERT
- PROPOSED UNDERGROUND COLLECTION
- PROPOSED OVERHEAD COLLECTION
- PROPOSED DEER GATE LOCATION

**NOTES:**

1. SEE SITE PLAN SHEETS C.401 THRU C.426 FOR LAYOUT OF ARRAY AND FACILITY FEATURES.
2. SITE PREPARATION INCLUDES BUT IS NOT LIMITED TO CLEARING/GRUBBING, MINOR GRADING, COMPACTION, MOWING OF VEGETATION, AND RESTABILIZATION OF DISTURBED AREA.
3. MINOR SURFACE SMOOTHING MAY OCCUR IN AREAS WHERE GRADING IS NOT PROPOSED FOR SAFETY OR SOLAR ARRAY INSTALLATION.
4. CONTRACTOR SHALL INSTALL ALL PERIMETER EROSION AND SEDIMENT CONTROL DEVICES PRIOR TO UPSLOPE DISTURBANCE ACTIVITIES.
5. ACCESS ROADS WILL BE CONSTRUCTED TO MATCH THE SURROUNDING EXISTING GROUND ELEVATIONS TO ALLOW THE CONTINUATION OF DRAINAGE PATTERNS. A CROWNED OR CONTINUOUS CROSS SLOPE WILL BE PROVIDED BASED ON SITE CONDITIONS.
6. OVERALL DRAINAGE PATTERNS WILL NOT BE ALTERED WITH SOLAR FACILITY.

**KEY MAP**

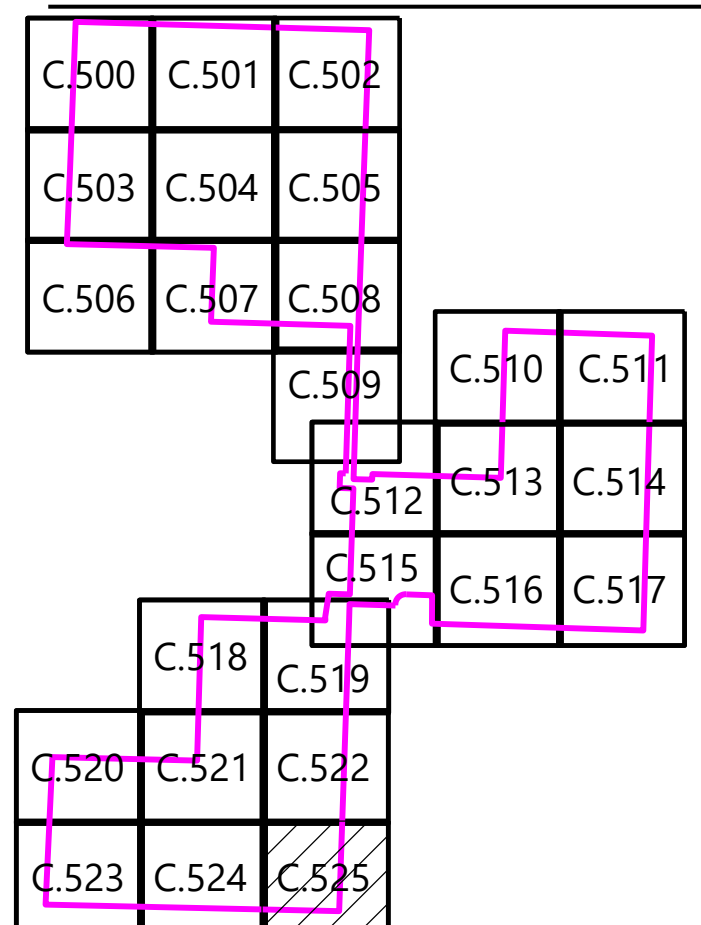

PREPARED FOR:



8400 Normandale Lake Blvd, Suite 1200  
 Bloomington, MN 55347

**REVISIONS:**

#	DATE	COMMENT	BY	CHK	APR
A	05/01/2023	Permit Plans	MB	BV	KA

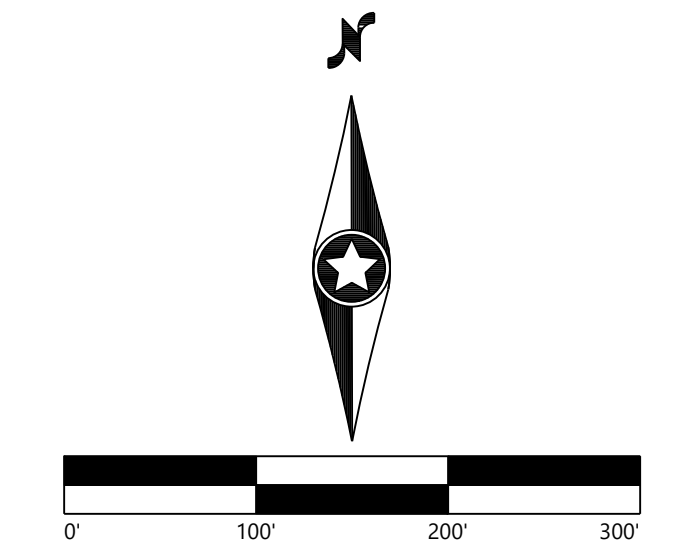

**Elk Creek Solar Project**  
 Rock County, MN

**Grading and Drainage Plan - 26**

**NOT FOR CONSTRUCTION**

DATE: 05/01/2023 REV:  
 SHEET: C.525 A

SEE SHEET C.425

3/20/2023 10:00 AM C:\Users\jgibson\OneDrive\Documents\Elk Creek Solar\Grading and Drainage\Grading and Drainage.dwg 3/20/2023 10:32 AM Matt Elmgren

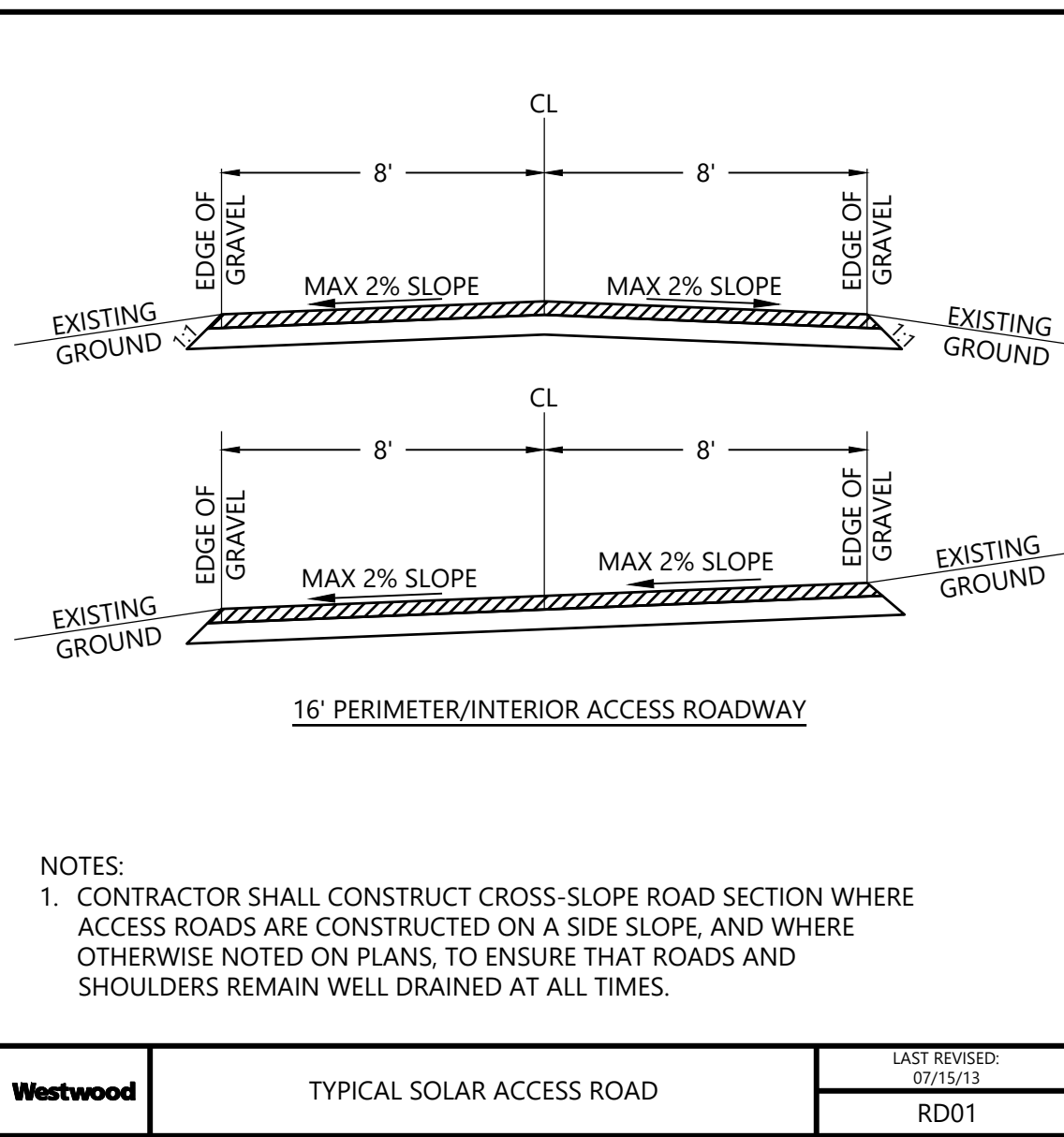

NOTES:  
1. CONTRACTOR SHALL CONSTRUCT CROSS-SLOPE ROAD SECTION WHERE ACCESS ROADS ARE CONSTRUCTED ON A SIDE SLOPE, AND WHERE OTHERWISE NOTED ON PLANS, TO ENSURE THAT ROADS AND SHOULDERS REMAIN WELL DRAINED AT ALL TIMES.

Westwood TYPICAL SOLAR ACCESS ROAD RD01

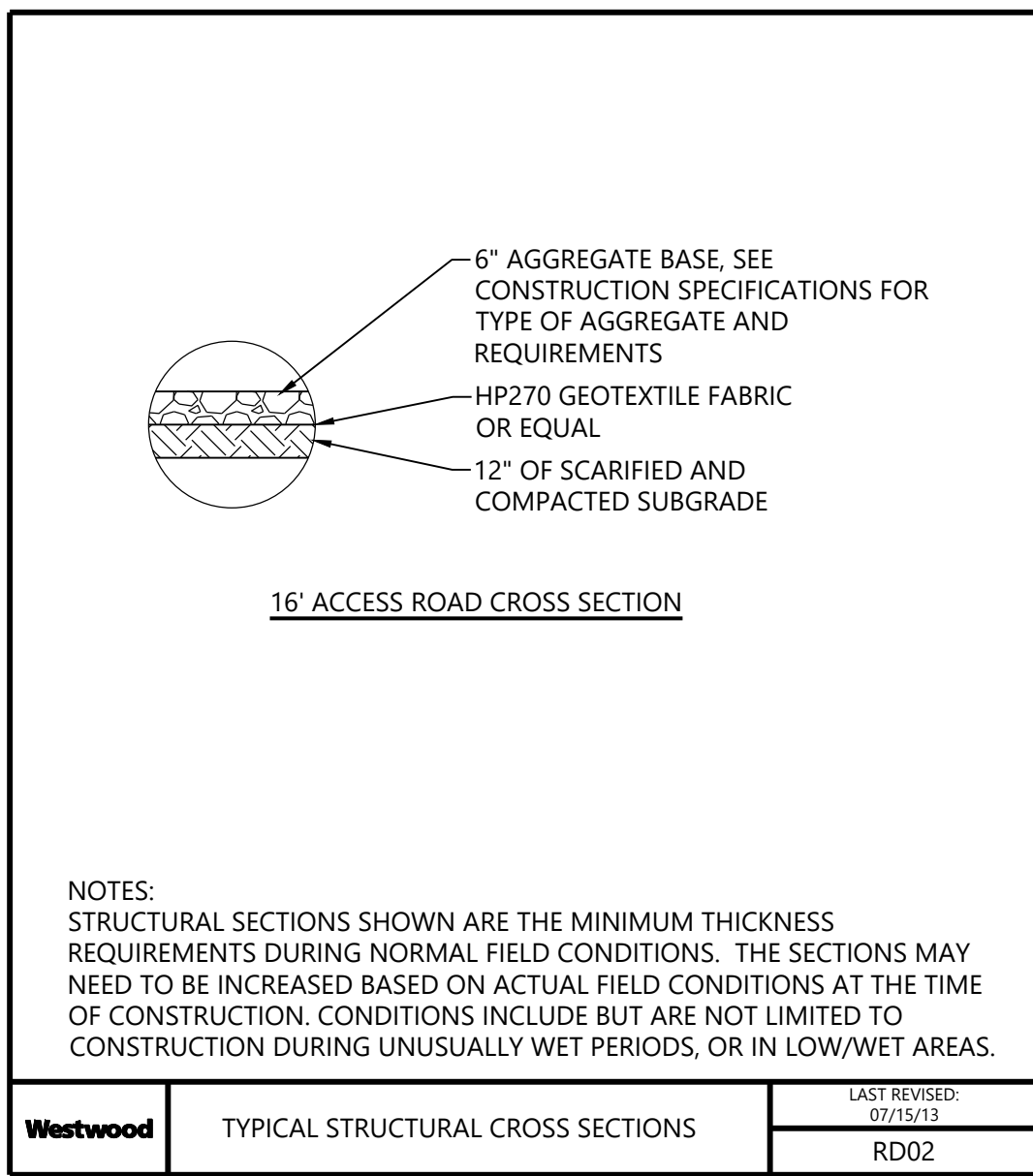

NOTES:  
STRUCTURAL SECTIONS SHOWN ARE THE MINIMUM THICKNESS REQUIREMENTS DURING NORMAL FIELD CONDITIONS. THE SECTIONS MAY NEED TO BE INCREASED BASED ON ACTUAL FIELD CONDITIONS AT THE TIME OF CONSTRUCTION. CONDITIONS INCLUDE BUT ARE NOT LIMITED TO CONSTRUCTION DURING UNUSUALLY WET PERIODS, OR IN LOW/WET AREAS.

Westwood TYPICAL STRUCTURAL CROSS SECTIONS RD02

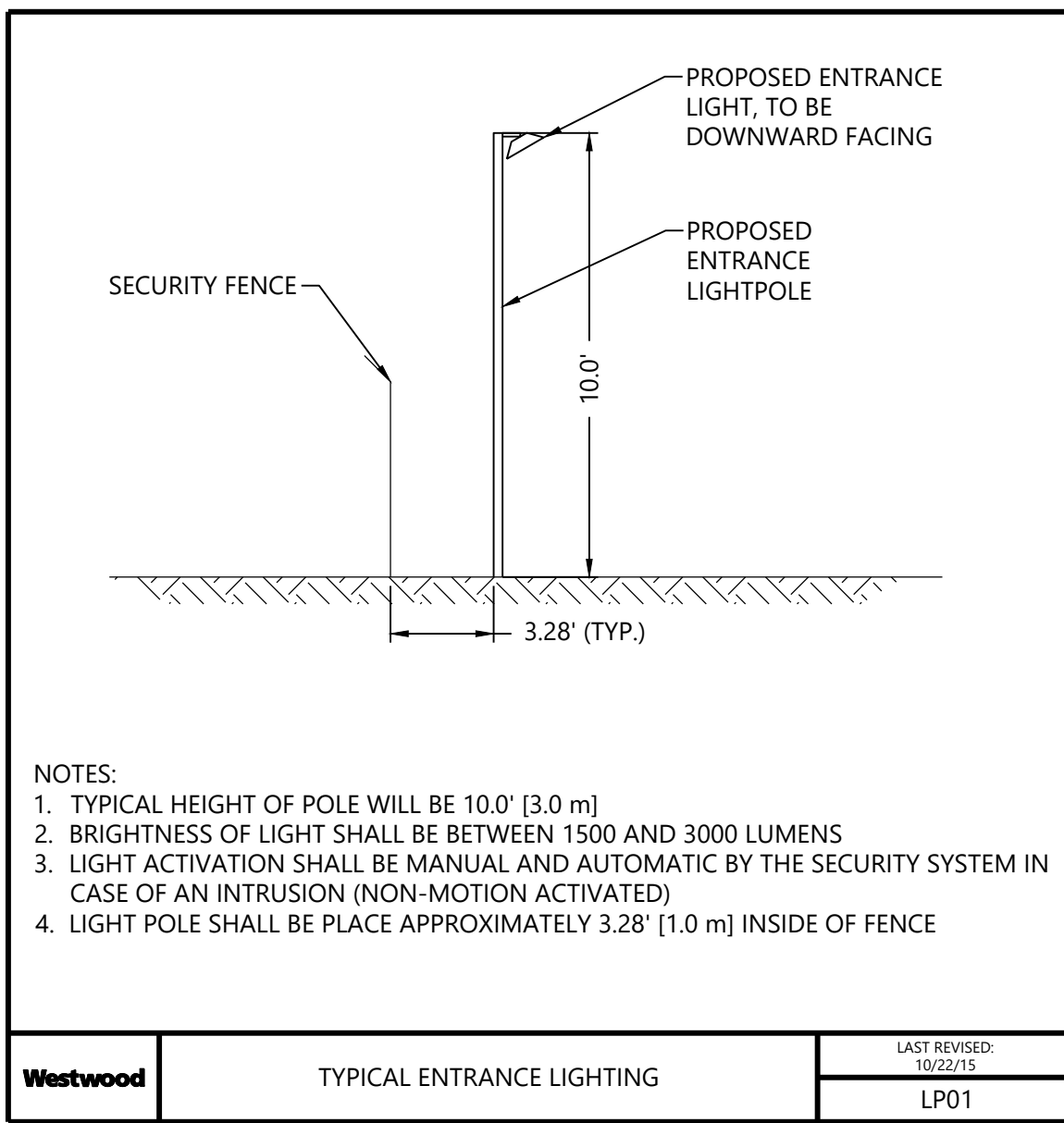

NOTES:  
1. TYPICAL HEIGHT OF POLE WILL BE 10.0' [3.0 m]  
2. BRIGHTNESS OF LIGHT SHALL BE BETWEEN 1500 AND 3000 LUMENS  
3. LIGHT ACTIVATION SHALL BE MANUAL AND AUTOMATIC BY THE SECURITY SYSTEM IN CASE OF AN INTRUSION (NON-MOTION ACTIVATED)  
4. LIGHT POLE SHALL BE PLACE APPROXIMATELY 3.28' [1.0 m] INSIDE OF FENCE

Westwood TYPICAL ENTRANCE LIGHTING LP01

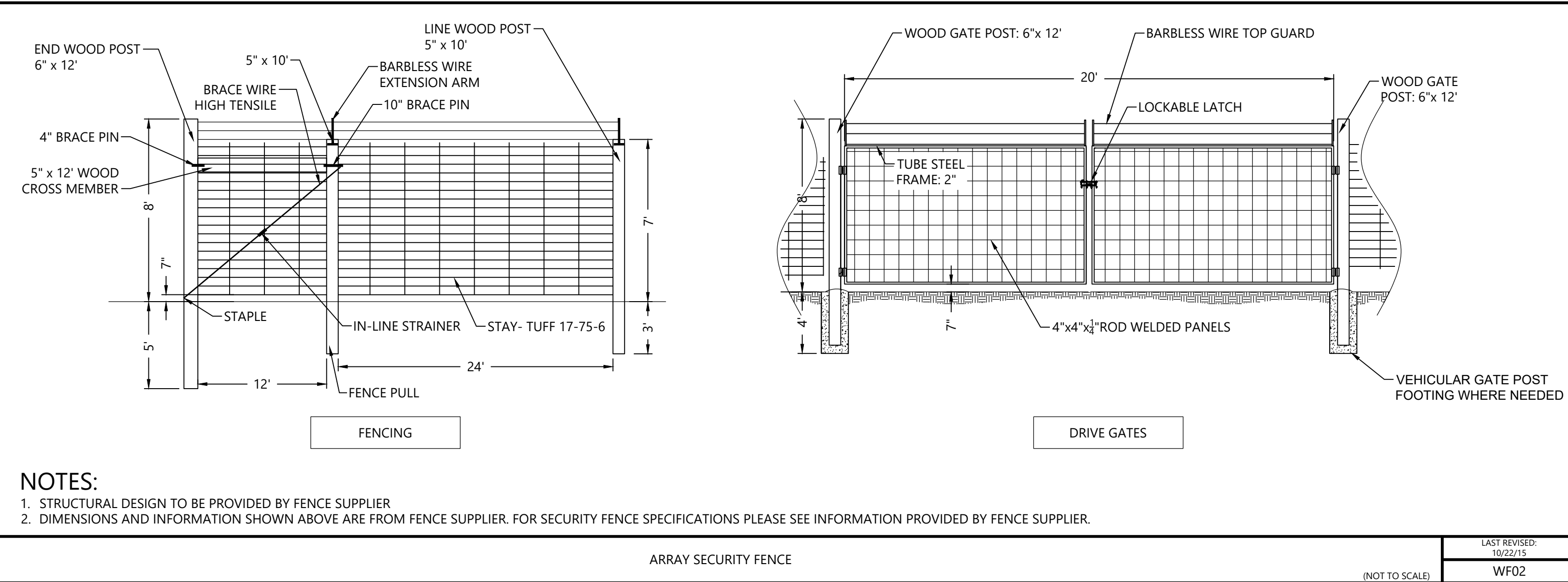

NOTES:  
1. STRUCTURAL DESIGN TO BE PROVIDED BY FENCE SUPPLIER  
2. DIMENSIONS AND INFORMATION SHOWN ABOVE ARE FROM FENCE SUPPLIER. FOR SECURITY FENCE SPECIFICATIONS PLEASE SEE INFORMATION PROVIDED BY FENCE SUPPLIER.

ARRAY SECURITY FENCE (NOT TO SCALE) WF02

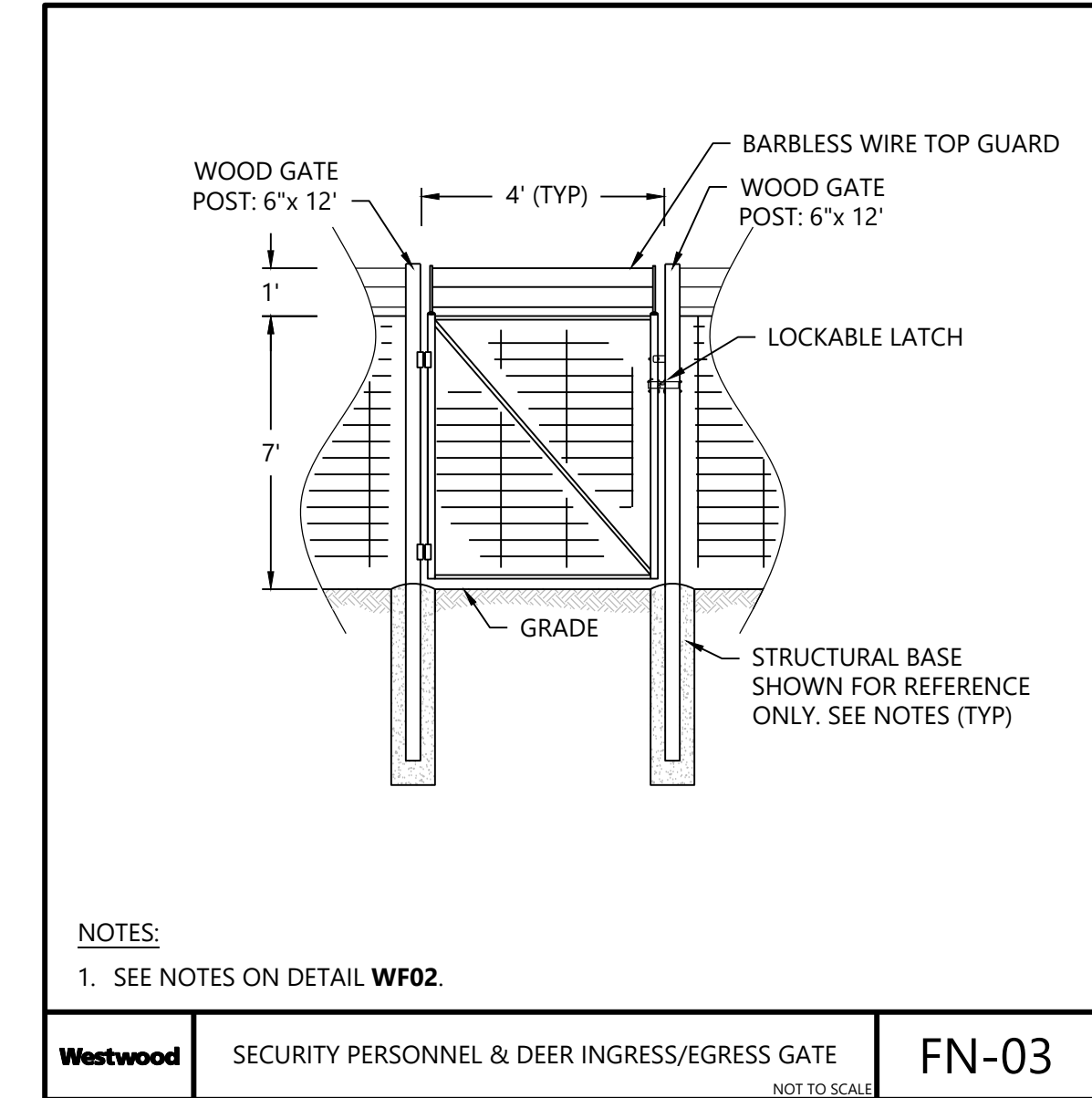

NOTES:  
1. SEE NOTES ON DETAIL WF02.

Westwood SECURITY PERSONNEL & DEER INGRESS/EGRESS GATE (NOT TO SCALE) FN-03

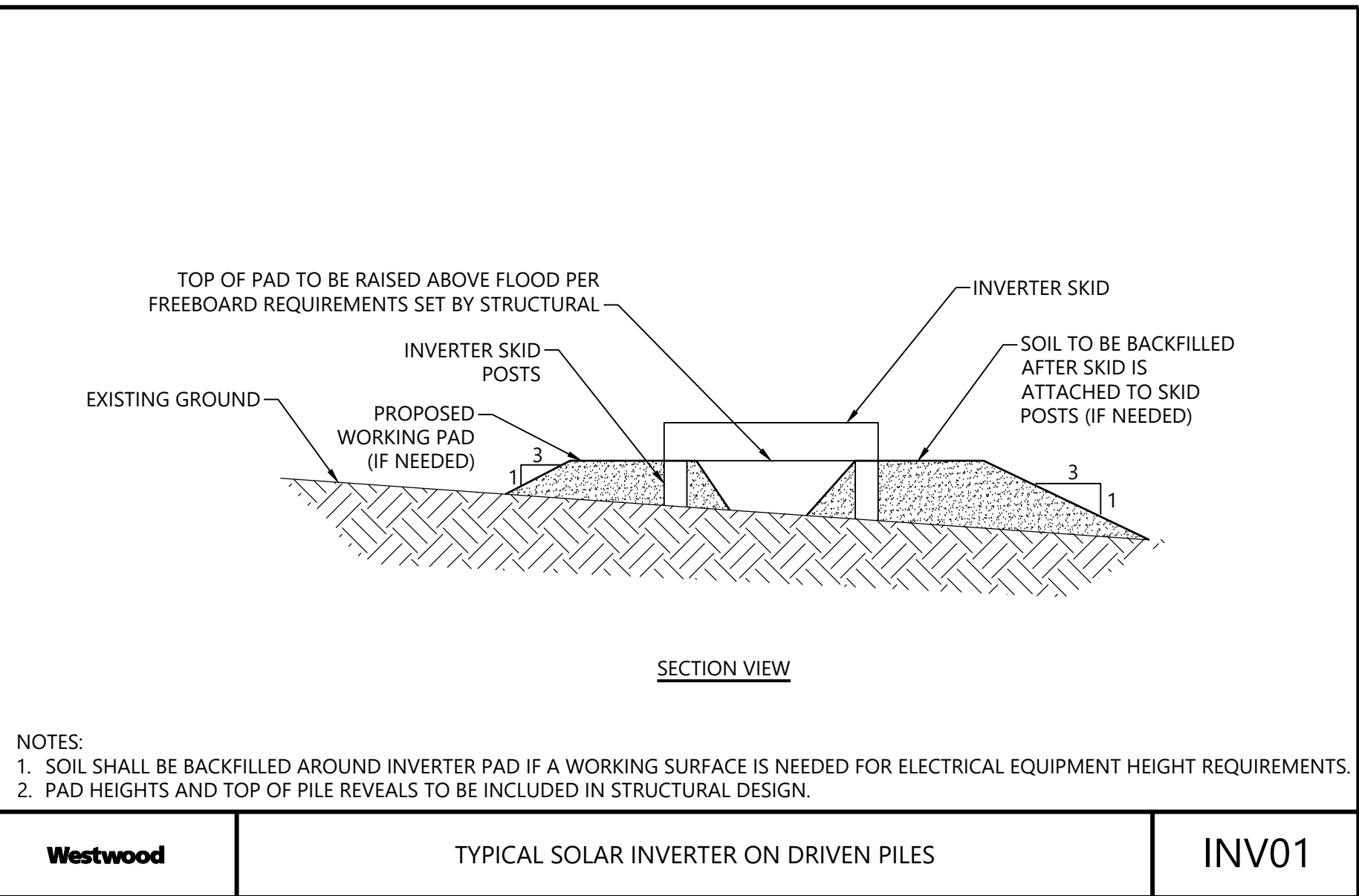

NOTES:  
1. SOIL SHALL BE BACKFILLED AROUND INVERTER PAD IF A WORKING SURFACE IS NEEDED FOR ELECTRICAL EQUIPMENT HEIGHT REQUIREMENTS.  
2. PAD HEIGHTS AND TOP OF PILE REVEALS TO BE INCLUDED IN STRUCTURAL DESIGN.

Westwood TYPICAL SOLAR INVERTER ON DRIVEN PILES INV01

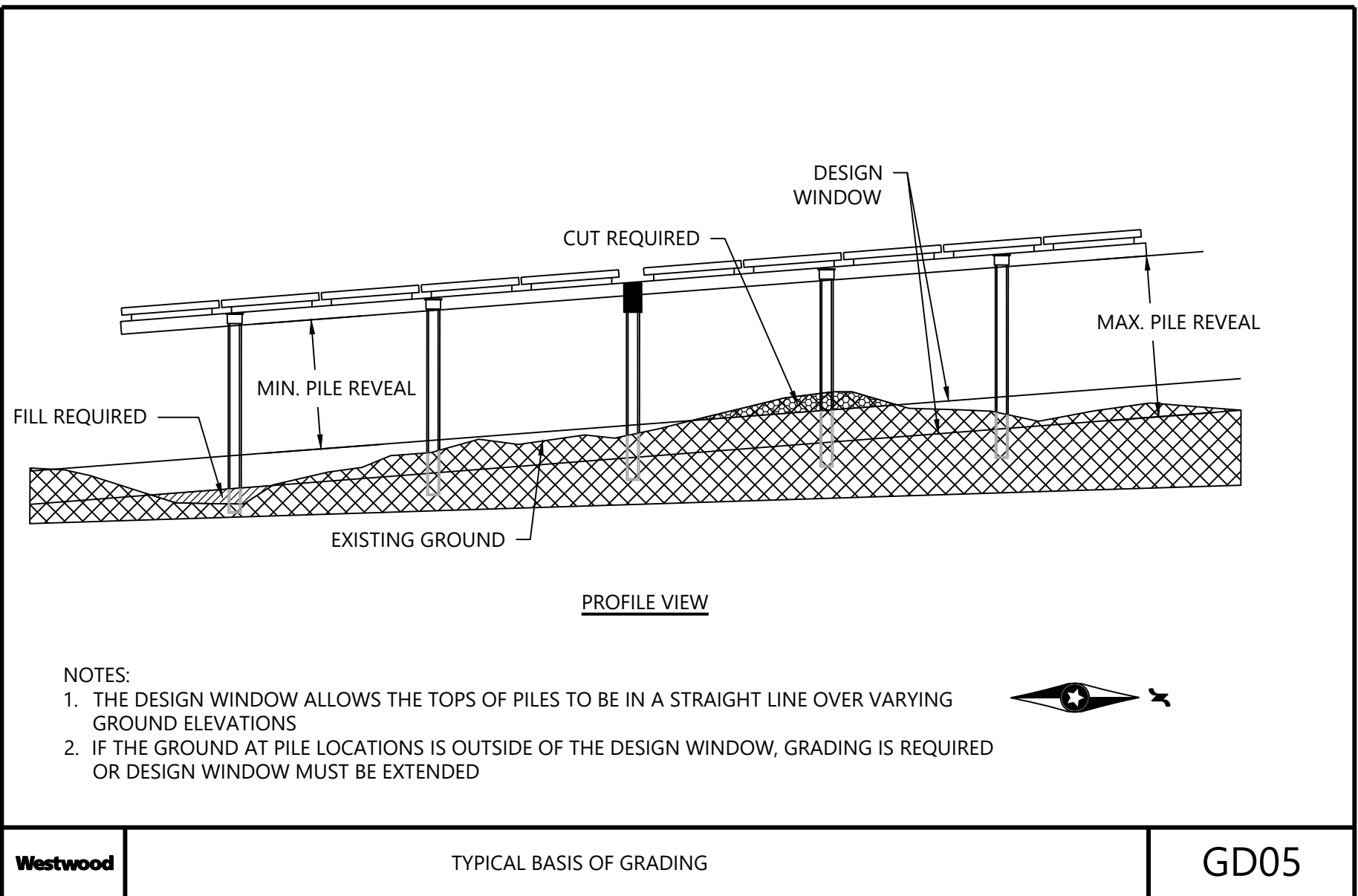

NOTES:  
1. THE DESIGN WINDOW ALLOWS THE TOPS OF PILES TO BE IN A STRAIGHT LINE OVER VARYING GROUND ELEVATIONS  
2. IF THE GROUND AT PILE LOCATIONS IS OUTSIDE OF THE DESIGN WINDOW, GRADING IS REQUIRED OR DESIGN WINDOW MUST BE EXTENDED

Westwood TYPICAL BASIS OF GRADING GD05

REVISIONS:

#	DATE	COMMENT	BY	CHK	APR
A	05/01/2023	Permit Plans	MB	BV	KA

**Elk Creek Solar Project**  
Rock County, MN

Road and Fence construction Details

NOT FOR CONSTRUCTION

DATE: 05/01/2023 REV:  
SHEET: C.600 A

D:\2023\1992023000.dwg: C:\Users\jgall@westwoodps.com\AppData\Local\Temp\1992023000.dwg: 5/1/2023 9:48 AM Westwood

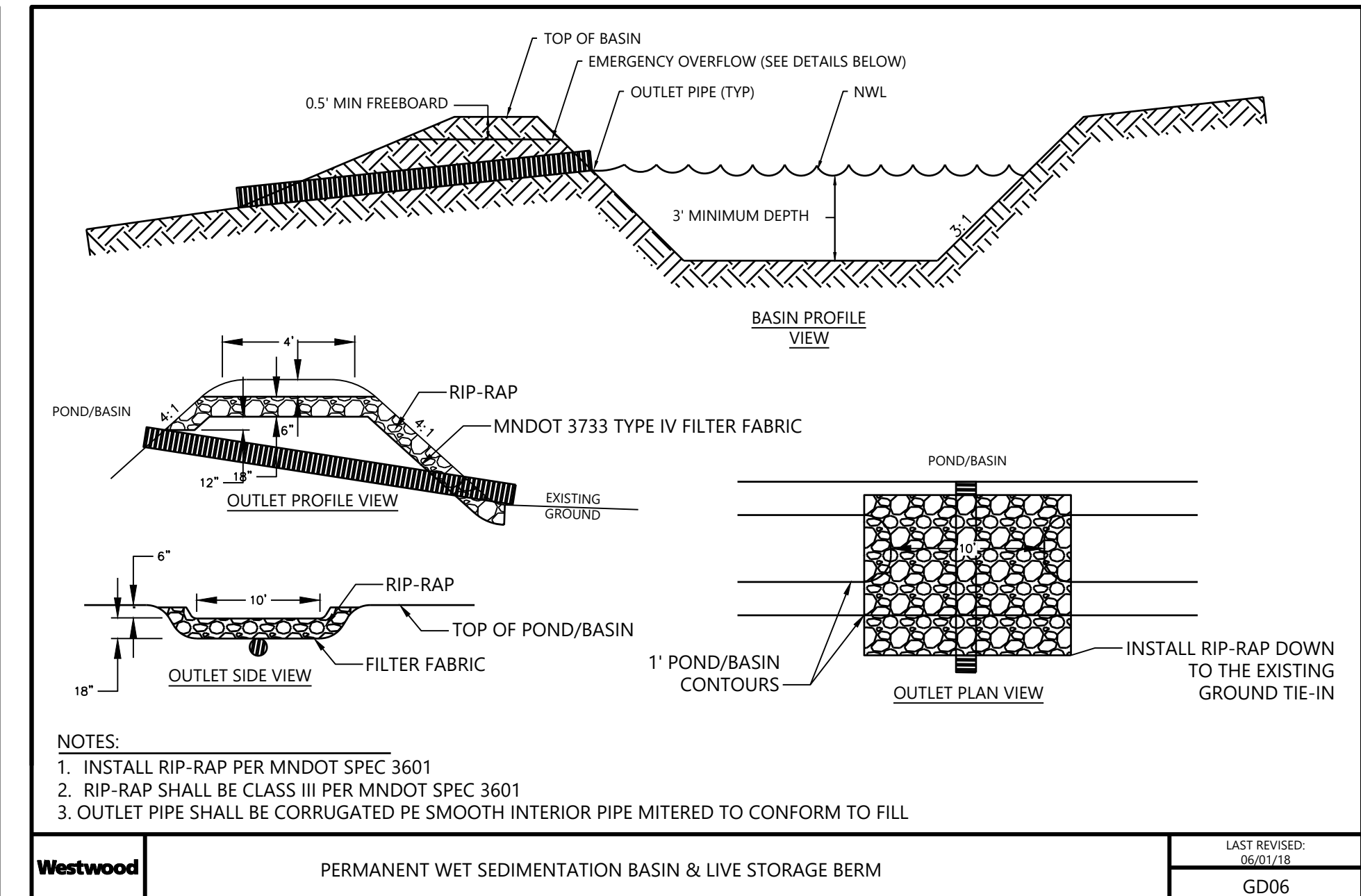
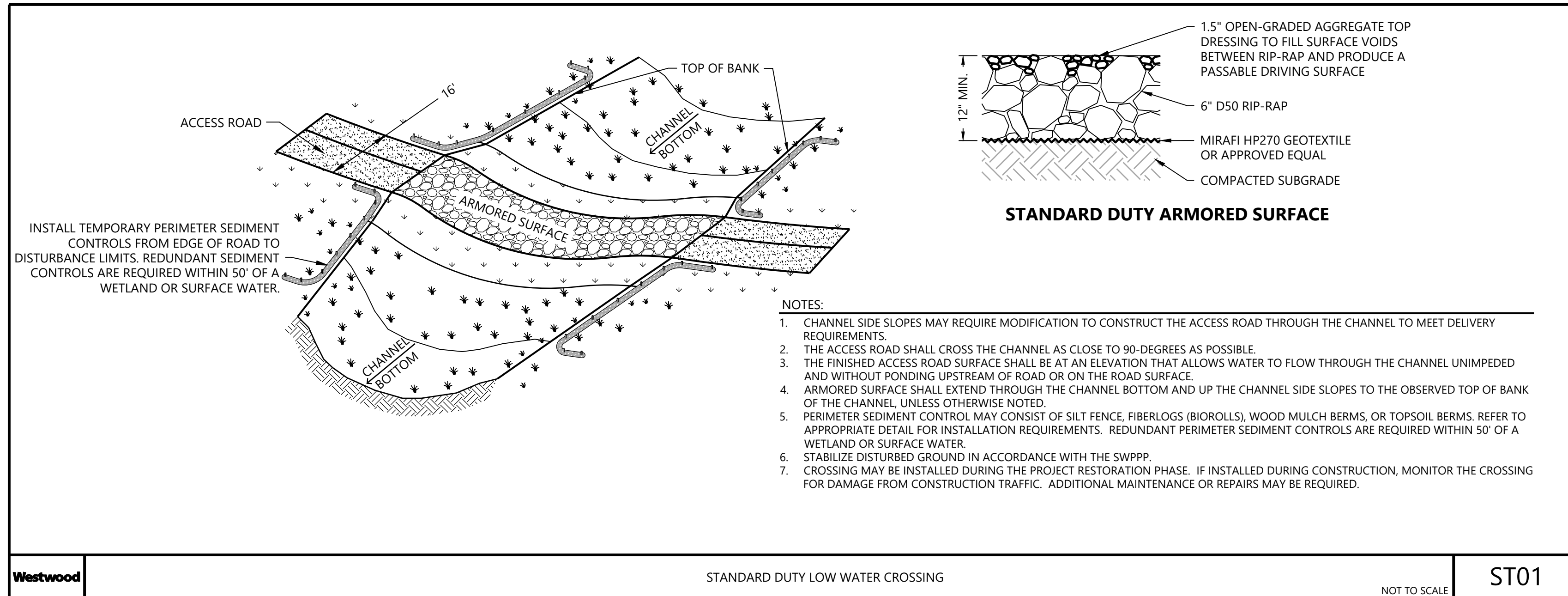

Westwood STANDARD DUTY LOW WATER CROSSING NOT TO SCALE ST01

Westwood PERMANENT WET SEDIMENTATION BASIN & LIVE STORAGE BERM LAST REVISED: 06/01/18 GD06

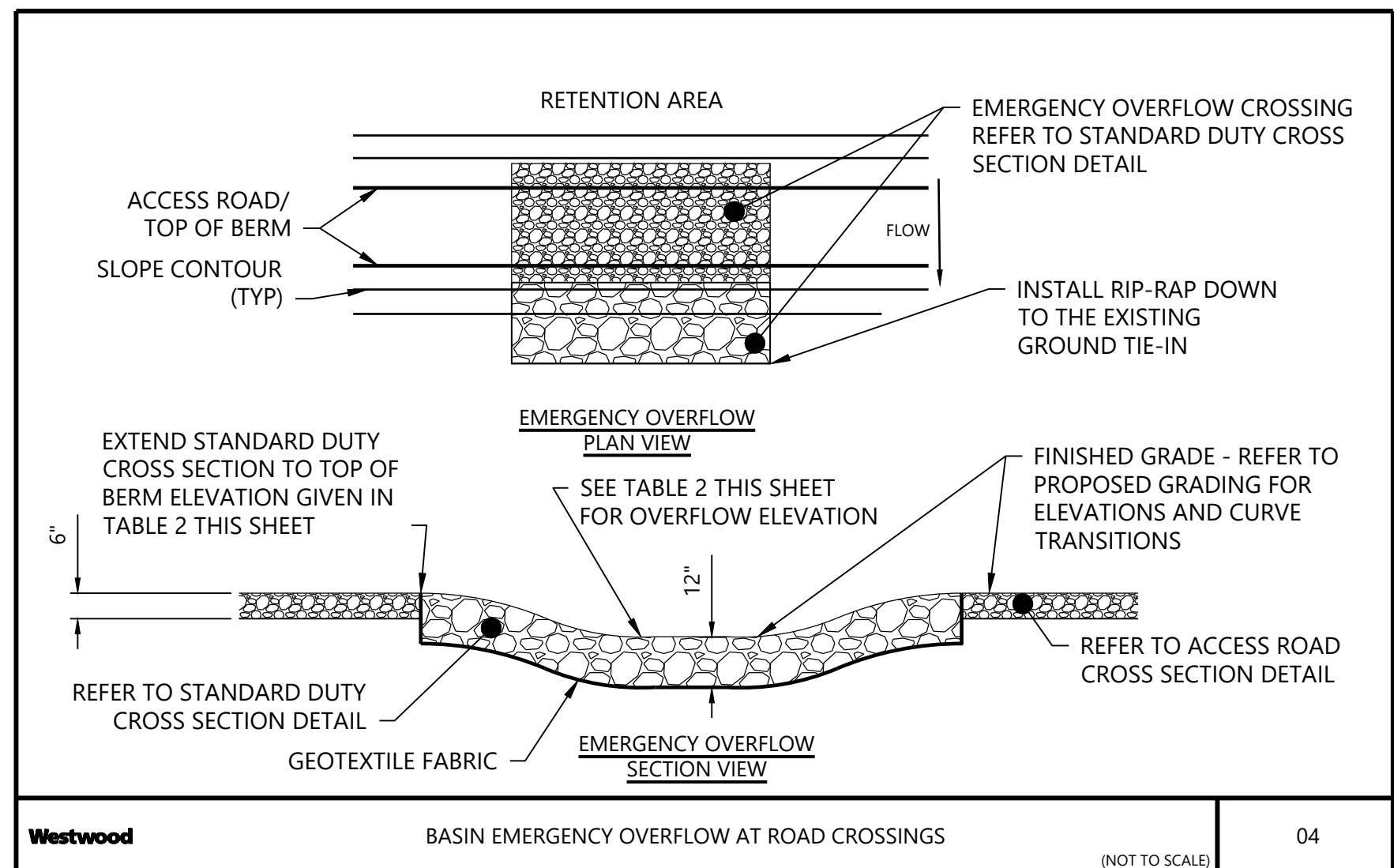
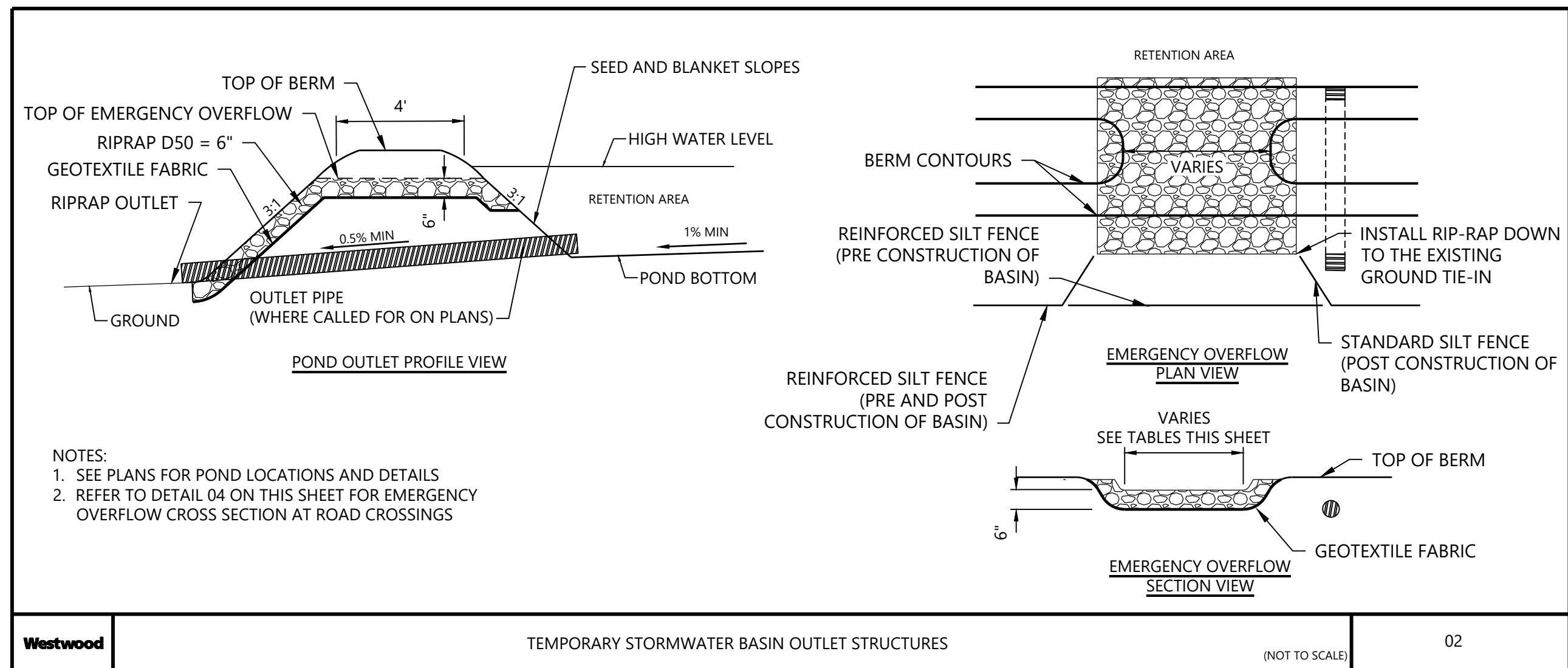

Westwood TEMPORARY STORMWATER BASIN OUTLET STRUCTURES (NOT TO SCALE) 02

Westwood BASIN EMERGENCY OVERFLOW AT ROAD CROSSINGS (NOT TO SCALE) 04

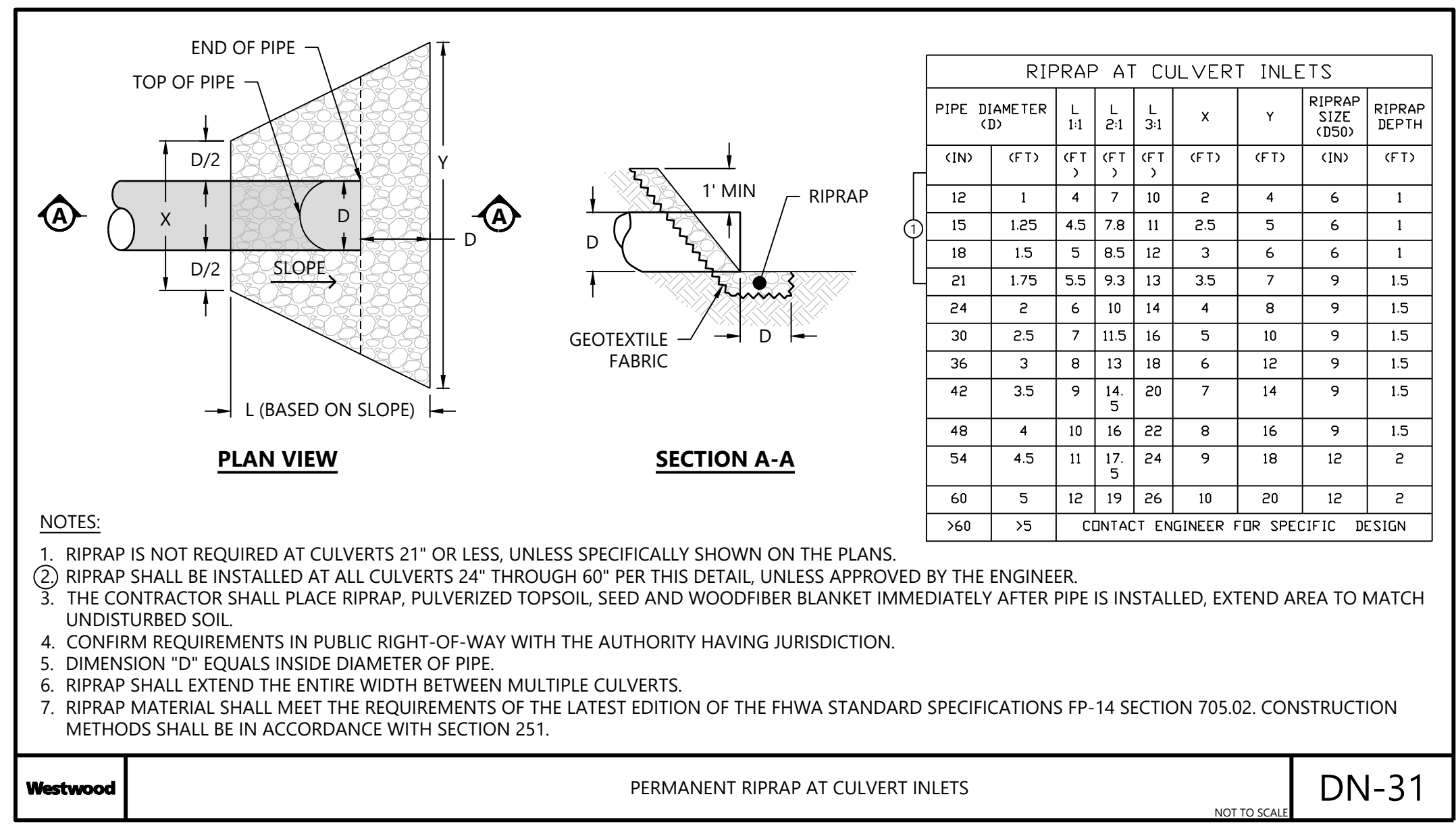
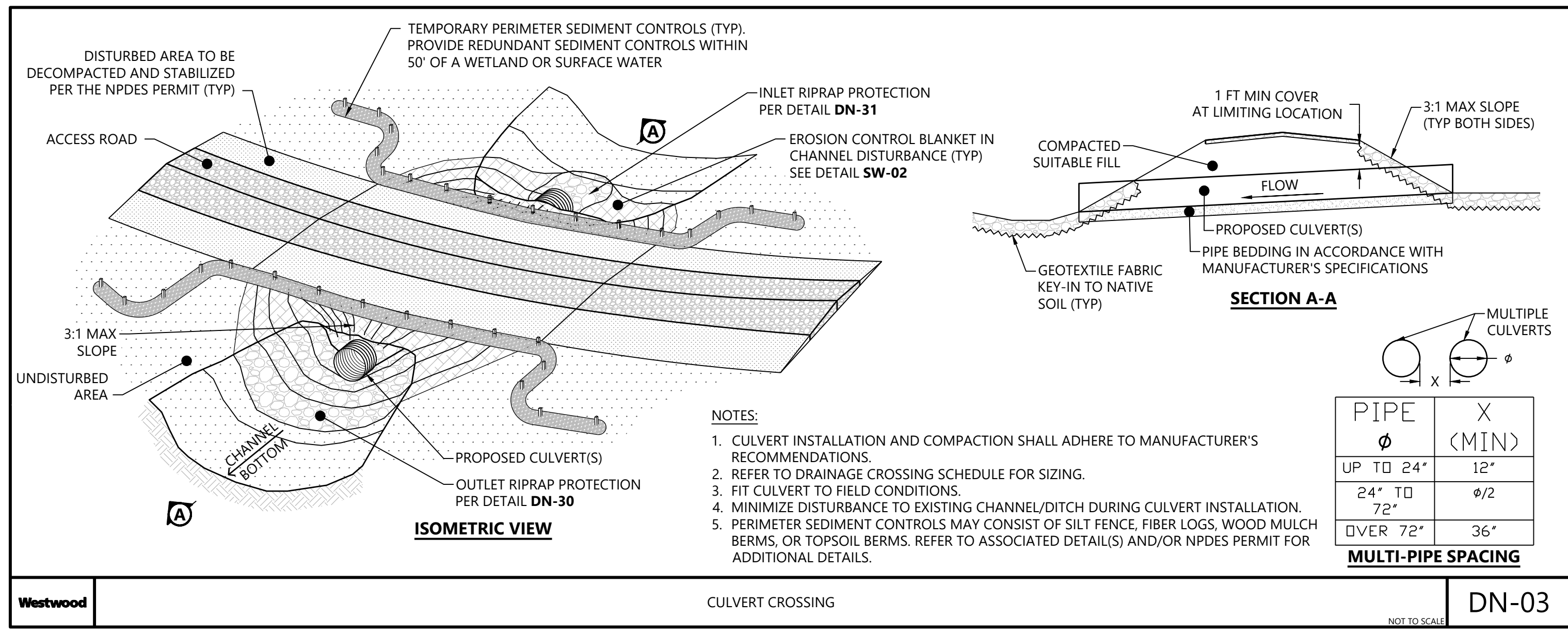

Westwood CULVERT CROSSING NOT TO SCALE DN-03

Westwood PERMANENT RIPRAP AT CULVERT INLETS NOT TO SCALE DN-31

**Elk Creek Solar Project**  
 Rock County, MN

Grading and Drainage Construction Details

NOT FOR CONSTRUCTION

DATE: 05/01/2023 REV: A  
 SHEET: C.601

PREPARED FOR:



8400 Normandale Lake Blvd, Suite 1200  
 Bloomington, MN 55347

REVISIONS:

#	DATE	COMMENT	BY	CHK	APR
A	05/01/2023	Permit Plans	MB	BV	KA

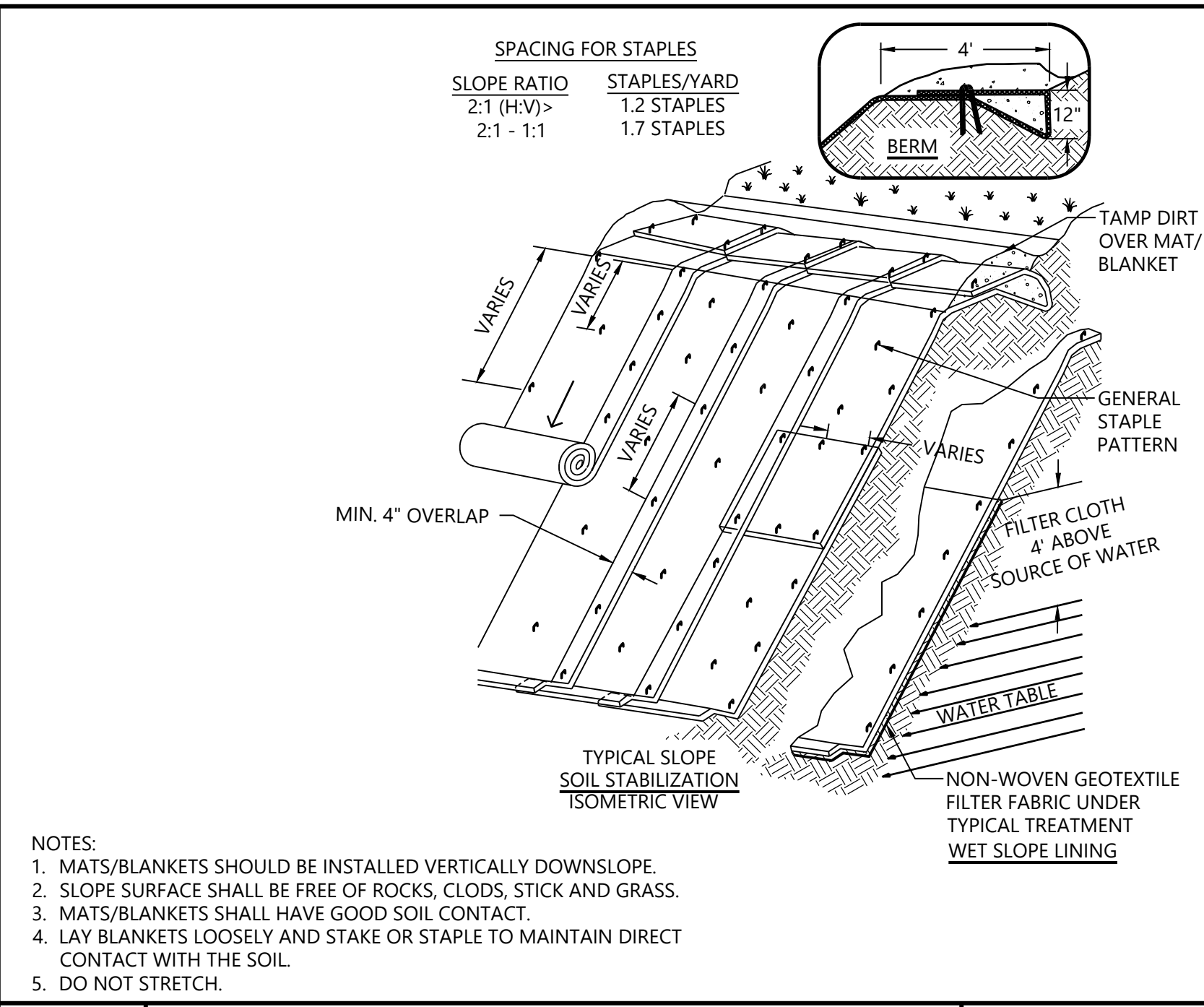

Westwood TEMPORARY EROSION BLANKETS TURF REINFORCEMENT MATS FOR SLOPE  
 LAST REVISED: 03/03/08  
 GD21

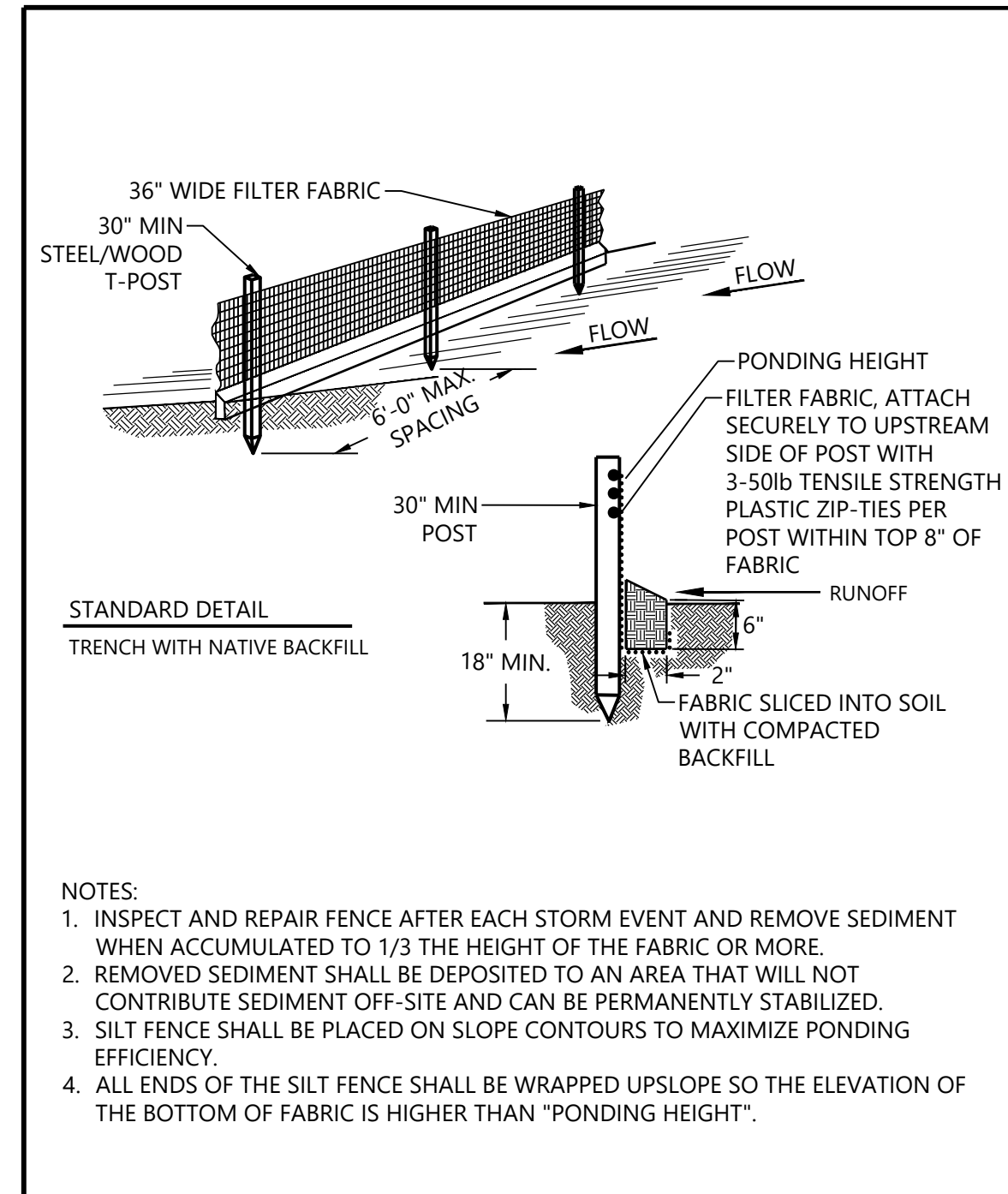

Westwood SILT FENCE  
 LAST REVISED: 1/10/14

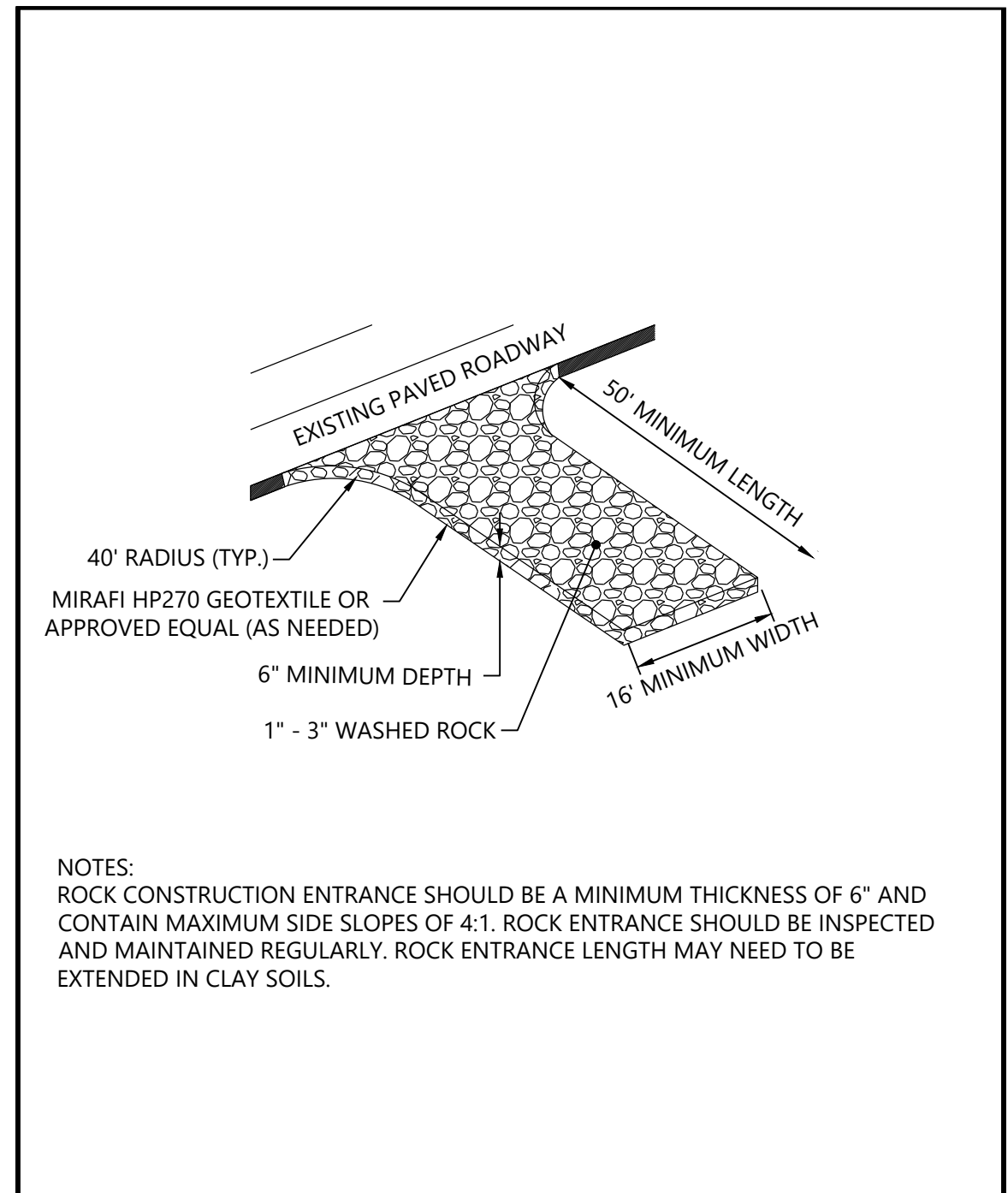

Westwood ROCK CONSTRUCTION ENTRANCE  
 LAST REVISED: 02/02/15  
 GD05

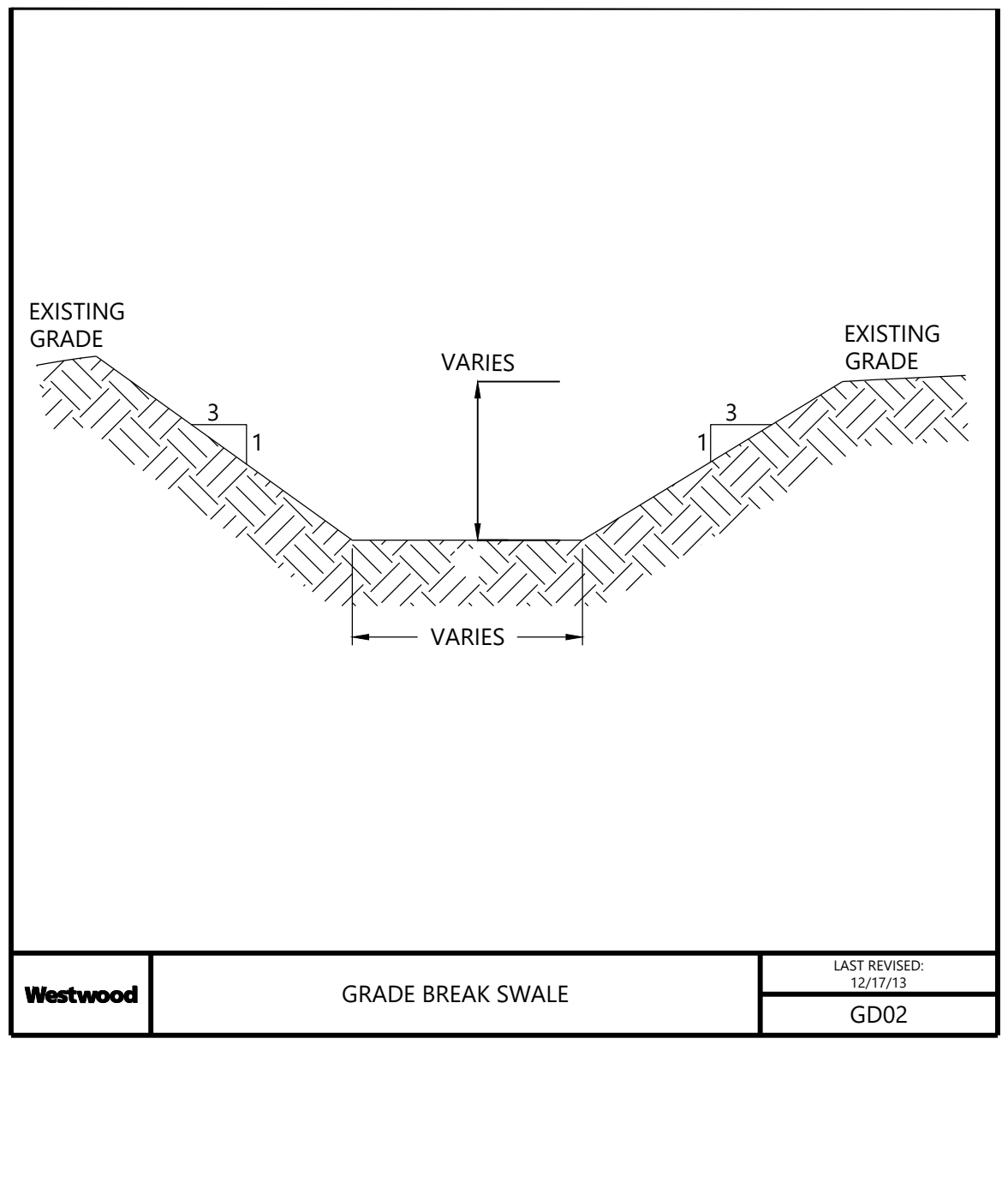

Westwood GRADE BREAK SWALE  
 LAST REVISED: 12/17/03  
 GD02

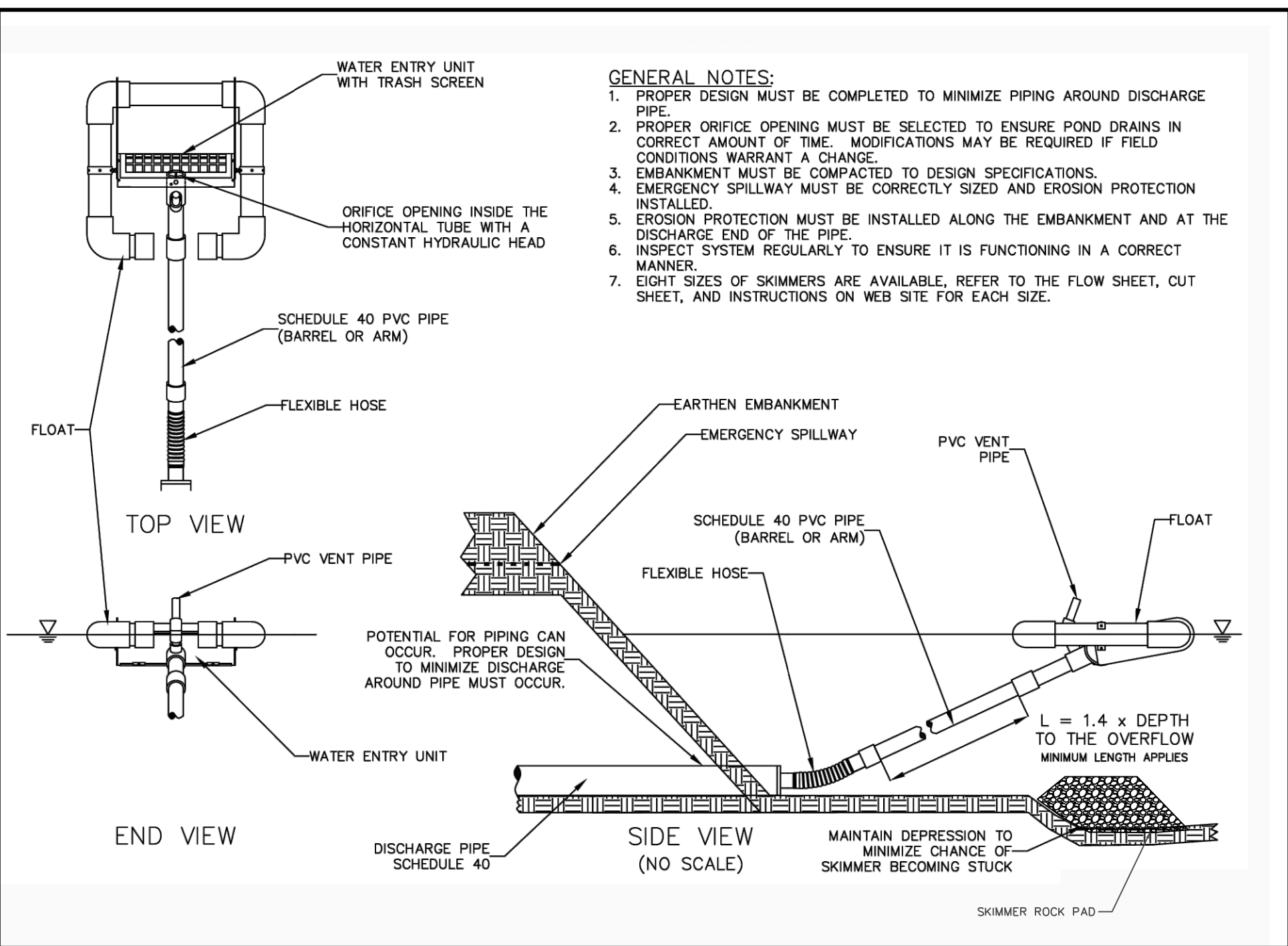

Westwood FAIRCLOTH SKIMMER DISCHARGE SYSTEM WITH EMBANKMENT  
 03

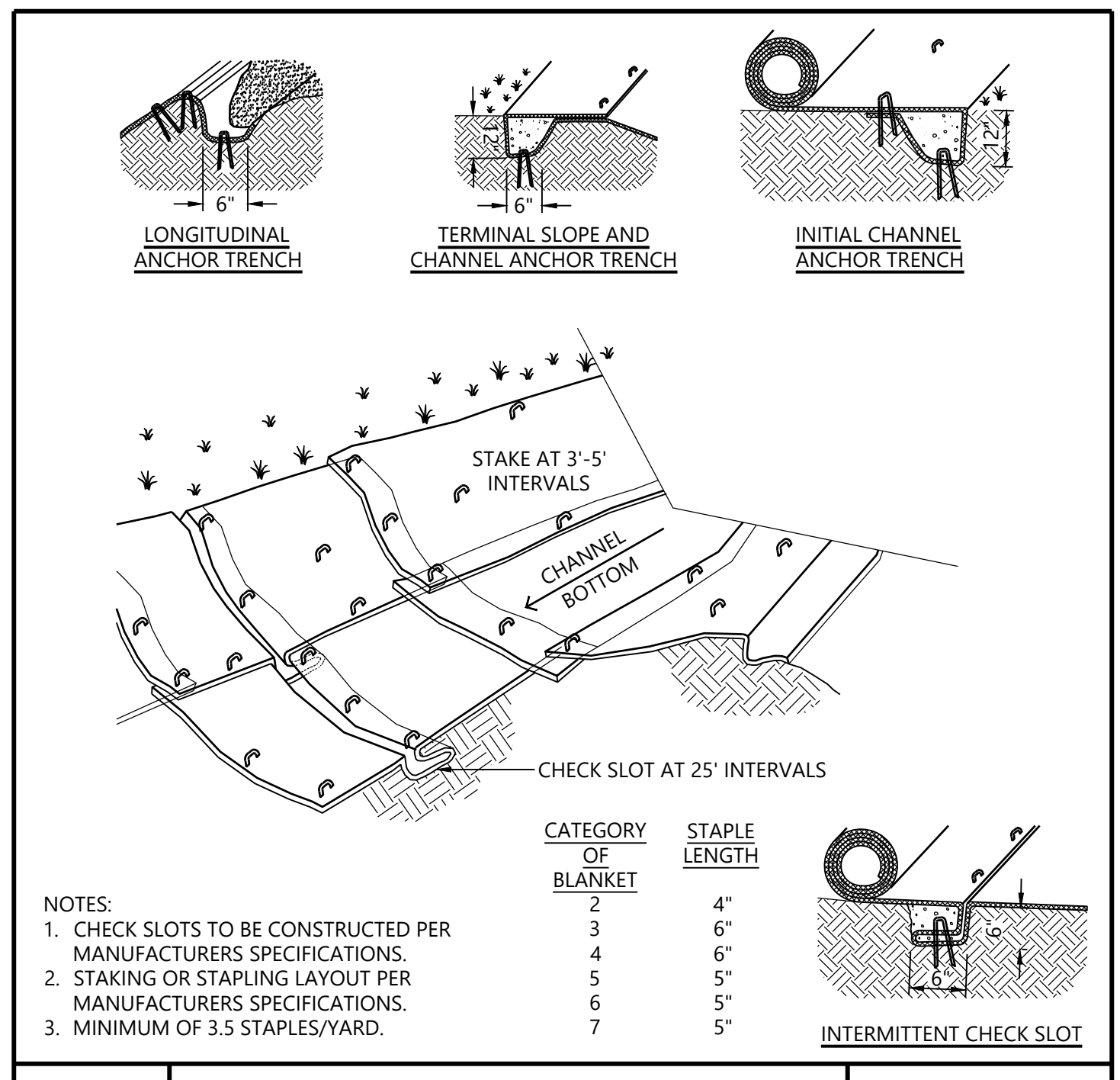

Westwood TEMPORARY EROSION BLANKETS TURF REINFORCEMENT MATS FOR CHANNEL  
 GD22

## Elk Creek Solar Project

Rock County, MN

Erosion & Sediment Control Details

NOT FOR CONSTRUCTION

DATE: 05/01/2023 REV:  
 SHEET: C.602 A

**Appendix D**  
**Agricultural Impact Mitigation Plan and**  
**Vegetation Management Plan**

---

*Agricultural Impact Mitigation Plan  
for the  
Elk Creek Solar Project*

---

**Elk Creek Solar, LLC**

**Rock County, MN**

**Revised May 2023**



**7650 Edinborough Way  
Suite 725  
Edina, MN 55435**

**Prepared by:**



## TABLE OF CONTENTS

1.0	PURPOSE AND APPLICABILITY OF PLAN .....	1
2.0	PROJECT OVERVIEW .....	3
2.1	Background .....	3
2.2	Project Components .....	4
2.2.1	Configuration of Solar Panels, Arrays, and Racking .....	4
2.2.2	Inverters, Transformers, and Electrical Collection System .....	5
2.2.3	Project Substation and Operations and Maintenance Building.....	6
2.2.4	Access Roads .....	7
2.2.5	Permanent Fencing.....	8
2.2.6	Stormwater Drainage Basins.....	8
2.2.7	Transmission System .....	8
2.2.8	Temporary Facilities .....	8
2.3	Construction.....	9
2.3.1	Site Clearing & Vegetation Removal .....	9
2.3.2	Earthwork.....	9
2.3.3	Access Road Construction .....	9
2.3.4	Solar Array Construction .....	9
2.3.5	Electrical Collection System.....	10
2.3.6	Inverter Installation.....	11
2.3.7	Project Substation Construction.....	11
2.3.8	Stormwater Drainage Bains .....	11
2.3.9	Generator-Tie Line Construction .....	12
2.3.10	Project Fencing Installation .....	12
3.0	LIMITATIONS AND SUITABILITY OF SITE SOILS.....	13
3.1	Land Use Considerations .....	13
3.2	Important Soil Characteristics.....	13
3.2.1	Selected Physical Characteristics: Texture, Slope, Drainage and Wetness, Topsoil Depth, Bedrock and Presence of Stones and Rocks .....	14
3.2.2	Selected Classification Data: Prime Farmland, Land Capability Classification, Hydric Soils. ....	16
3.2.3	Construction-Related Interpretations: Highly Erodible Land (Wind and Water), Compaction Prone, Rutting Prone, and Drought Susceptible with Poor Revegetation Potential.....	19
3.2.4	Summary of Major Soil Limitations at the Elk Creek Solar Project .....	20
4.0	BMPS DURING CONSTRUCTION AND OPERATION .....	22
4.1	Environmental Monitor.....	22
4.2	Soil Segregation and Decompaction.....	23
4.3	Wet Weather Conditions.....	23
4.4	Adaptive Management During Construction .....	24
4.5	Initial Grading/Road Construction/Array Construction.....	24
4.6	Foundations.....	25
4.7	Trenching .....	25

4.8	Temporary Erosion and Sediment Control .....	26
4.9	Drain Tile Identification, Avoidance and Repair.....	26
4.9.1	Pre-Construction Tile Mapping and Repair .....	26
4.9.2	Project Design Considerations .....	27
4.9.3	Construction Measures.....	28
4.9.4	Operational Measures .....	28
4.10	Construction Debris .....	28
5.0	DECOMMISSIONING.....	29
5.1.1	Timeline .....	29
5.1.2	Removal and Disposal of Project Components .....	29
5.1.3	Restoration/Reclamation of Facility Site .....	30

### LIST OF TABLES

Table 1:	Acreage of Soils with Selected Physical Characteristics by Project Feature within the 2023 Land Control Area .....	15
Table 2:	Acreage of Soils with Selected Classification Data by Project Feature within the 2023 Land Control Area .....	18
Table 3:	Acreage of Soils in Selected Construction-related Interpretations by Project Feature within the 2023 Land Control Area .....	19

### LIST OF FIGURES

Figure 1 – Project Location
Figure 2 – 2023 Land Control and Preliminary Development Areas
Figure 3 – Preliminary Project Layout
Figure 4 – Detailed Preliminary Project Layout

### LIST OF APPENDICES

Appendix A – Selected Soil Physical Features, Classifications, and Interpretations and Limitations
Appendix B – NRCS Soil Map for the Project
Appendix C – Vegetation Management Plan, Revised April 2023



**ABBREVIATIONS & DEFINITIONS**

AC	alternating current
AIMP or Plan	Agricultural Mitigation Plan
BMPs	best management practices
Contractor	construction contractor
CSAH	County State Aid Highway
DC	direct current
decompaction	Treatment which relieves soil compaction by introducing air space into the soil.
drain tile	System that removes excess water from the soil; typically, below-ground.
GPS	global positioning system
kV	kilovolt
Elk Creek Solar or Elk Creek	Elk Creek Solar, LLC
2023 Land Control Area	Approximate 1,521.5-acre area of privately-owned land for which Elk Creek Solar, LLC has a purchase option
LCC	Land Capability Class
Monitor	environmental monitor
MDA	Minnesota Department of Agriculture
MNDNR	Minnesota Department of Natural Resources
MW	megawatts
NPDES	National Pollutant Discharge Elimination System
NRCS	Natural Resources Conservation Service
O&M building	operations and maintenance building
2023 Preliminary Development Area	Approximate 1,161.3-acre area where Elk Creek Solar, LLC proposes to build the Elk Creek Solar Project facilities
Project, Project Site, or Project Area	Elk Creek Solar Project
PV	photovoltaic
SCADA	Supervisory Control and Data Acquisition
SSURGO	Soil Survey Geographic Database
SWPPP	Stormwater Pollution Prevention Plan
Tile Contractor	agricultural drain tile contractor

## 1.0 PURPOSE AND APPLICABILITY OF PLAN

---

The objective of this Agricultural Impact Mitigation (the Plan or AIMP) and the accompanying Vegetation Management Plan (available in Appendix C) is to identify measures that Elk Creek Solar, LLC (Elk Creek Solar/Elk Creek) and its contractors will take to avoid, and/or repair potential negative agricultural impacts that may result from the construction, operation, and eventual decommissioning of the Elk Creek Solar Project (Project, Project Site, Project Area). Although Elk Creek Solar will own or lease the property on which the Project is constructed, and would cease agricultural production on the land during the life of the Project, this Plan outlines measures to ensure the land may be returned to future agricultural usages following the closure and decommissioning of the Project, including descriptions of best management practices (BMPs) that will be used during construction to minimize long-term impacts to soil. It is important to note that while Elk Creek Solar and the construction contractor (the Contractor) hired to build the facility fully intend to adhere to the specifics of this plan, certain practices may vary as the Contractor identifies methods that work more efficiently in this specific location and provide the highest degree of safety while constructing the facility.

In September 2019, Elk Creek submitted applications to the Commission for a Certificate of Need (CN) and a Site Permit (SP) for the Elk Creek Solar Project. The Commission issued Orders approving the CN and Site Permit on December 31, 2020, under Docket Nos. IP-7009/CN-19-351 and IP-7009/GS-19-495, respectively. At that time, the Project was proposed as a solar energy conversion facility with an 80-megawatt (MW) alternating current (AC) nameplate capacity (2020 Project). In this request for a site permit amendment, Elk Creek is requesting Commission approval to increase the Project boundary from 976 acres to 1,522 acres to accommodate an increase in the nameplate capacity of the Project to the full 160 MWs that Elk Creek has executed Generation Interconnection Agreements for with the Midcontinent Independent System Operator (MISO) and transmission owner. Elk Creek has two executed agreements for 80 MW each.

Elk Creek Solar consulted with the Minnesota Department of Agriculture (MDA) in April 2019 to discuss the AIMP's contents and site-specific characteristics. MDA also reviewed and commented on draft versions of the AIMP. The Plan presented here incorporates agency feedback on the 2019 version of the Plan as well as updates necessary to account for the expanded project boundary.

The strategy outlined in this Plan consists of creating a native prairie habitat within the footprint of the solar project while the Project is in operation. Typically, a solar site has a shorter prairie mix within the panel footprint, taller prairie plantings in the open space between the fence and array, and a wet seed mix for any wetlands or areas anticipated to hold water. The mixes are designed to be native and are developed with prairie specialists in coordination with the Minnesota Department of Natural Resources (MNDNR) to design a mix that will achieve Elk Creek's goals for operating the solar facility, promote pollinator habitat, establish stable ground cover successfully, reduce erosion, reduce runoff, and improve infiltration. MNDNR has reviewed the proposed seed mixes and approves of their use. Additionally, the contracted restoration company will work with Elk Creek to develop implementation plans for maintenance of the prairie throughout the life of the Project. More information on maintenance of the prairie is outlined in the Vegetation Management Plan.

This Plan is separated into several distinct sections: Section 2 provides an overview of the Project and its components. Section 3 addresses limitations and suitability of the soils at the Project area, Section 4 discusses the BMPs that will be used during construction and operation of the Project, and Section 5 outlines decommissioning.

## 2.0 PROJECT OVERVIEW

---

### 2.1 Background

Elk Creek Solar, a wholly owned subsidiary of National Grid Renewables Development, LLC (NG Renewables), proposes to construct the Elk Creek Solar Project on approximately 1,521.5 acres (2023 Land Control Area) of land in Magnolia Township, Section 3, Township 102 North, Range 44 West and Vienna Township, Sections 27, 34, and 35, Township 103 North, Range 44 West, Rock County, Minnesota (Figure 1 – Project Location). Elk Creek Solar anticipates that approximately 1,161.3 acres (2023 Preliminary Development Area) will be affected by Project facilities (Figure 2 – Land Control and Preliminary Development Areas). The Project lies north of Interstate 90 between County State Aid Highway (CSAH 8 and 9) approximately three miles north of the Town of Magnolia and 6 miles northeast of the City of Luverne Minnesota. The Project will generate up to 160 megawatts (MW), enough energy to provide electricity for approximately 27,600 homes annually and avoid the emission of approximately 219,000 metric tons of carbon annually.<sup>1</sup> Elk Creek plans to construct the Project on a schedule that facilitates an in-service date by the end of 2025.

The Project will interconnect to the adjacent Magnolia Substation, which is owned and operated by ITC Midwest. Elk Creek Solar selected this site due to its proximity to existing and planned transmission facilities, existing road infrastructure, and the relatively flat, unobstructed terrain on the Project site. Importantly, in selecting the Project site, Elk Creek Solar also concluded that its development will not result in significant environmental impacts.

The Project Site is on a nearly level to gently rolling loess-mantled glacial till plain consisting of gray, calcareous pre-Wisconsin-aged till covered by a thin to thick mantle of Wisconsin-aged Loess. The nearly-level topography combined with highly fertile soils, favorable moisture holding characteristics, and usually adequate supplies of moisture from precipitation are well suited to agriculture, which is currently the dominant land use for the Project Area. Swales and depressions that were historically wet have been converted by subsurface drainage to highly productive farmland.

Elk Creek has a combination of lease agreements and purchase options for the Project site. After issuance of the Site Permit and prior to construction of the Project, Elk Creek will purchase a portion of the Project site from the underlying landowners with purchase options and the leases will enter into the construction and operations terms. Land that is under lease and which will not be utilized by the Project will revert back to the underlying landowner for continued agricultural use.

---

<sup>1</sup> Based on EPA Greenhouse Gas Equivalencies Calculator and 309,000,000 kWh (309,000 MWhs) annual production PVSYST model.

## 2.2 Project Components

The Project will include the following major components, systems and associated facilities:

- Solar panels, racking system, and inverters
- Electrical collection system
- Project substation
- Operations and maintenance building (O&M building)
- Access roads
- Up to two weather stations (up to 20 feet tall)
- Perimeter fencing

Each of these components is described in more detail below.

### 2.2.1 Configuration of Solar Panels, Arrays, and Racking

The Project will convert sunlight into direct current (DC) electrical energy within photovoltaic (PV) panels. For purposes of describing construction, the Project can be considered an aggregate of individual PV panel components interconnected by cabling and infrastructure at increasing scales to ultimately deliver up to 160 MW of nameplate alternating current (AC) of electricity to the existing Magnolia substation currently on the electrical grid and immediately adjacent to the Project. From smallest to largest scales Project components are described below and presented on Figure 4 (Detailed Preliminary Project Layout):

1. **Individual PV panels** are approximately 4 to 7 feet long by 2 to 4 feet wide by 1 to 2 inches thick and are installed on metal foundations that are driven or screwed into the ground.
2. **Lines** of interconnected PV panels consist of a line of short-edge butted panels approximately 370-feet long, with each line oriented to and rotating along a north-south axis to track the east-west movement of the sun and maximize the interception of solar energy. These lines represent the racking upon which the individual panels are mounted upon.
3. **Arrays** PV of north/south lines of PV panels organized in racks associated with an east/west oriented access road.
4. **Blocks** of PV panels typically consist of one or two arrays north, and one or two arrays south of a permanent access and maintenance road. Depending on site constraints, there may be fewer arrays associated with a specific block.
5. **Construction Units** consist of Blocks of PV panels delineated by their connectivity and relationship to main roads. The Project consists of:
  - a. a 435.7-acre (approximate) **North Unit** bounded by 141<sup>st</sup> Street to the south, 151<sup>st</sup> Street to the North, 180<sup>th</sup> avenue to the west, and 190<sup>th</sup> Avenue to the east.
  - b. a 402.3-acre (approximate) **Central Unit** bounded by 131<sup>st</sup> Street to the south, 141<sup>st</sup> Street to the north, 190<sup>th</sup> Avenue to the west, and CSAH 3 to the east. An existing 161 kV transmission line bisects the Central Unit.
  - c. a 323.3-acre (approximate) **South Unit** bounded by 121<sup>st</sup> Street to the south, 131<sup>st</sup> Street to the north, 180<sup>th</sup> Avenue to the west, and 190<sup>th</sup> avenue to the east.

6. Approximately 3,170 feet of electrical collection system along the west side of 190<sup>th</sup> Avenue to connect the northern units to the Project substation in the central unit. The AC collection system may be installed either above-ground or below-ground depending on final engineering design (see Figures 3 and 4).

Elk Creek Solar will use a linear axis tracking system where the panels within a line are rotated by small motors to track with the sun throughout the day. The panels aligned in rows north and south face east in the morning, parallel to the ground during mid-day, and then west in the afternoon. Panels can be manually oriented to the east or west at maximum tilt angle to facilitate maintenance access and vegetation management, if necessary, although spacing between the panel edges when at a horizontal position is typically 13 feet and sufficient for maintenance vehicles.

## **2.2.2 Inverters, Transformers, and Electrical Collection System**

Electrical wiring will connect the panels to inverters, which will convert the power from DC to AC. The AC will be stepped up through a transformer from the inverter output voltage to 34.5 kV and brought via the collection cables to the Project substation. The electrical collection system will be installed below-ground or a hybrid of below-ground and above-ground. Electrical collection technology is rapidly evolving and will be site-specific depending on geotechnical analysis, constructability, costs, and availability of materials. Final engineering and procurement will help determine the construction method for the electrical collection system. The electrical cables that would be used for each type of electrical collection system are described below.

Regardless of the collection system configuration (below-ground or hybrid), the Project will utilize central inverter/transformer skids at locations throughout the Project and include a transformer to which the inverters will feed electricity. The final number of inverters for the Project will depend on the inverter size, as well as inverter and panel availability. The Project's preliminary design proposes 89 central inverter skids (one inverter is required for every 2-3 MW). These skids provide the foundation for the inverter, transformer, and Supervisory Control and Data Acquisition (SCADA) system. The skids will be placed atop a concrete slab or pier foundations and typically measure 10 feet wide by 25 feet long, with a structure height of approximately 12 feet above grade. Concrete foundations will be poured onsite or precast and assembled off-site. The inverters are within the interior of the Project along access roads.

### **2.2.2.1 Below-ground Electrical Collection System**

volts of AC. Then a step-up transformer converts the inverter AC voltage to an intermediate voltage of 34.5kV. The panels deliver DC power to the inverters through cabling that will be located in a below-ground trench (approximately four feet deep and one to two feet wide). Below-ground AC collection systems from the inverter skids to the substation will be installed in trenches or ploughed into place at a depth of at least four feet below grade. During all trench excavations the topsoil and subsoil will be removed and stockpiled separately. Once the cables are laid in the trench, the area will be backfilled with subsoil followed by topsoil.

As noted above, the AC collection line connecting the northern unit to the Project substation may be installed either below-ground or above-ground, depending on final engineering design. If installed above-ground, the AC collection line would be moved above-ground just outside of the

fenced area via a riser installed in the southeastern corner of the northern unit, near the intersection of 190<sup>th</sup> Avenue and 141<sup>st</sup> Street. Approximately 11 poles spaced roughly 300 feet apart would be installed along the west side of 190<sup>th</sup> Avenue. The first pole would be just outside the fenceline of the northern unit, and the collection line would extend for about 0.6 mile before turning east, crossing over 190<sup>th</sup> Avenue, and connecting to another pole installed adjacent to the fenceline of the central unit. From here, the collection line would be moved below ground as it continues to the Project substation.

The preliminary design includes two pole types (wooden double-circuit tangent and steel dead-end structure) to avoid and minimize environmental impacts on agricultural activities. The double circuit tangent poles are made of wood, approximately 60-feet tall, have a diameter of 18 inches, and will be direct embed. Tangent poles are sometimes referred to as “straight-through” poles as they are generally used along relatively straight portions of a line. Tangent poles used for the Project will carry collection cables on one side of the pole to minimize the width of the collector right-of-way used by the Project. Tangent poles are used for the majority of the corridor from the northern unit along 190<sup>th</sup> Avenue. Steel dead-end double circuit poles are made of steel, approximately 60-feet tall, have a diameter of up to 6 feet, and will require concrete foundations. These dead-end structures are used for road crossings, and in certain soil conditions where excess strain is placed on the pole or its components. Pole placement is included on Figures 3 and 4. The pole placement included in this AIMP is preliminary and final locations will be determined based on final engineering and geotechnical analysis.

#### **2.2.2.2 Hybrid Below-ground and Above-ground Electrical Collection System**

A hybrid above-ground and below-ground electrical system is being considered for the Project for several reasons including ease of access for operations and maintenance, reduced ground disturbance, and cost considerations. If above-ground cabling is utilized, the DC collection lines will be strung under each row of panels on steel arms and a steel cable attached to the piles. At the end of each row, hanging brackets would connect several racks/rows of cables to a common collection point near their assigned inverter/transformer skid where the cables will be routed below-ground at a minimum depth of at least four feet below grade to the inverter/transformer skid where the current is converted to AC and voltage is stepped up to 34.5 kV.

From the inverter/transformer skids, AC collection lines would be installed below ground to the Project substation. As noted above, the collection corridor between the northern unit and the central unit may be installed above ground, depending on final engineering design; a description of the above-ground collection line between the northern and central units is provide in Section 2.2.2.1.

#### **2.2.3 Project Substation and Operations and Maintenance Building**

The Project substation will be a 34.5/161 kV step-up substation with metering and switching gear required to connect to the transmission grid. It will be designed according to regional utility practices, Midcontinent Independent Transmission System Operator Standards, Midwest Reliability Organization Standards, National Electrical Safety Code, and the Rural Utility Service Code. The area within the substation will be graveled to minimize vegetation growth in the area

and reduce fire risk. The substation will be fenced with a 6-foot chain-link fence, topped with one foot of barbed wire for security and safety purposes. The substation's area will be approximately 150 feet by 150 feet once construction is complete.

An O&M building will provide access and storage for Project maintenance and operations and will be located adjacent to the Project substation. The Project will obtain a building permit for the O&M building from Rock County prior to construction. The O&M building will measure approximately 60 feet long by 40 feet wide and will be made of metal (similar to a pole barn). It will contain an office for the onsite Plant Manager, a technician room, restroom, and storage area for equipment to operate and maintain the Project. Equipment includes a SCADA cabinet, spare panels, spare parts for the substation and equipment to operate the substation, as well as safety equipment for working with live electricity.

A parking lot will be located adjacent to the O&M building and will be approximately 500 square feet with the final size being determined in accordance with the Rock County Planning and Zoning Ordinance. The parking lot will be gravel or paved depending on the size to comply with the parking and loading regulations detailed in Section 29 of the Rock County Planning and Zoning Ordinance (Rock County, 2000).

#### **2.2.4 Access Roads**

The Project will include approximately 11.1 miles of graveled access roads that lead to the inverters and Project substation for operation and maintenance. The final length of the access roads will depend on the equipment selected and final engineering. These roads are up to 16 feet wide along straight portions of the roads and wider along curves at internal road intersections (approximately 45 feet). There are nine access points to the Project from existing county roads. These entrances will have locked gates.

Elk Creek has designed access roads for effective and efficient access for operations and maintenance and for safe ingress and egress of employees, visitors, and emergency responders. Elk Creek has minimized the amount of access roads for the Project. For example, access roads provide access to all portions of the site and every central inverter, but not every block of panels has access roads along the entire perimeter (i.e., along the perimeter fence). This design minimizes the amount of ground disturbance and new impervious surfaces while still providing effective and efficient site access.

Some upgrades or other changes to the public roads may be required for construction or operation of the Project. Elk Creek will work with Rock County to facilitate and pay for required upgrades that meet the required public standards. Upgrades or changes could include, but are not limited to, road improvements, additional aggregate, and driveway changes. Road improvements may require a road use and repair agreement with Rock County and/or Vienna and Magnolia Townships; Elk Creek will continue to coordinate with both agencies as the Project develops. Driveway changes will require a county entrance permit from Rock County, which will be obtained prior to construction.



### **2.2.5 Permanent Fencing**

Permanent security fencing will be installed along the perimeter of the solar arrays and 2023 Preliminary Development Area. Fencing will be secured to posts which will be directly embedded in the soil or set in concrete foundations as required for structural integrity. The fencing will consist of an agricultural woven wire fence and will extend approximately 6 feet above grade. At the request of MNDNR, barbed wire will not be used around the perimeter of the Project, and instead one foot of 3-4 strands of smooth wire will be used for a total height of approximately 8 feet above grade. Additional gates will be strategically installed at corners for deer egress and contact information for the site manager will be posted at the gates. However, the fencing around the substation will be a 6-foot above grade chain-link fence and include one foot of barbed wire to comply with the National Electric Code. This fencing will be designed to prevent the public from gaining access to electrical equipment which could cause injury. Additionally, the fencing will prevent larger wildlife from entering the facility.

### **2.2.6 Stormwater Drainage Basins**

Elk Creek has preliminarily designed 28 drainage basins throughout the 2023 Preliminary Development Area that range in size from 0.3 to 5.5 acres. These basins are located in existing low areas that also contain hydric soils and for which the preliminary design for solar facilities has avoided. These areas will be vegetated with a wet seed mix that will help stabilize soils after rain events.

### **2.2.7 Transmission System**

The Project will interconnect into the existing Magnolia Substation via a 161-kV overhead gen-tie transmission line of less than 1,500 feet. ITC Midwest plans to expand the existing Magnolia Substation approximately 250 feet to the south to accommodate interconnection of the Project (Figures 3 and 4). The Magnolia Substation would expand into land that is currently row crop agriculture or otherwise maintained by ITC Midwest as part of the existing substation property. The associated interconnection infrastructure will be similar to what was approved in the 2020 Site Permit.

There will be a single dead-end structure within the Project substation and likely 2-3 additional structures to enter the Magnolia Substation with an overall length currently estimated to be approximately 500 feet, pending final engineering. The structures will likely be made of wood and will be less than 150 feet tall. The type of conductor will be determined following the completion of detailed electrical design. Per Minn. Stat. 216E.01 subd. 4, the transmission line does not meet the high voltage transmission line definition because it's less than 1,500 feet. As such, a separate route permit from the Commission will not be required for the gen-tie line.

### **2.2.8 Temporary Facilities**

Elk Creek will utilize seven temporary laydown areas within the 2023 Preliminary Development Area, totaling 11.2 acres. These areas will serve both as a parking area for construction personnel and staging areas for Project components during construction. These laydown areas have been sited to avoid any tree clearing. After construction, the laydown areas will be reseeded as described in the Vegetation Management Plan.

## **2.3 Construction**

### **2.3.1 Site Clearing & Vegetation Removal**

Depending on timing of the start of construction, the Project may require the clearing of residual row-crop debris from the 2024 harvest season. Alternatively, and depending on construction timing, Elk Creek may plant a cover crop in Spring 2025 that is compatible with the Project's Vegetation Management Plan (Appendix C). This cover crop would stabilize soils if row crops are not planted that year.

### **2.3.2 Earthwork**

The majority of soil disturbances will occur during the first phase of Project construction when the grading activities take place. The Contractor may need to move some soils to “flatten” certain parts of the local terrain or, at the very least, to complete minor grading of topsoils. The earthwork activities will be completed using typical civil construction equipment – scrapers, bulldozers, front-end loaders, back-hoes or skid-steers. BMPs that will be used during these earthmoving activities are described in detail in Section 2.3.3 - Access Road Construction.

### **2.3.3 Access Road Construction**

As a component of earthwork, permanent access roads and permanent turnouts will be developed as indicated in Figures 3 and 4. This work would start with the stripping and segregating of topsoil materials from the anticipated 16-foot-wide road width. The Contractor will then compact the subgrade materials 16-feet wide to the specified compaction requirements as laid out by the civil and geotechnical engineer. After suitable compaction levels are reached and verified, the Contractor will then install the road as designed, typically done with or without geo-fabric depending on the soil type and then a surface of 4 to 12 inches of gravel. The gravel will be placed level with the existing grade to facilitate drainage and minimize ponding.

After gravel is installed and compacted to engineers' requirements, the Contractor will shape Project drainage ditches as identified on the final grading plan. Finally, the previously stripped and windrowed topsoil material will be re-spread throughout the Project Area.

Elk Creek has chosen low-relief areas within the Project Area to support Project infrastructure thus minimizing the amount of topsoil that will need to be removed due to grading. Topsoil removed from permanent access roads will be removed to suitable locations near the site of removal and graded for storage. Storage locations will be identified (global positioning system [GPS] boundary and depth) and recorded on site maps to facilitate final reclamation after decommissioning.

### **2.3.4 Solar Array Construction**

Once grading activities are complete, the racking system supports will be constructed using steel piles driven into the ground. In some situations where soils are low strength or consist of loose, non-cohesive sand, helical screw or auger-type foundation posts may be used. Foundations are typically galvanized steel and used where high load bearing capacities are required. The pile is driven using a hydraulic ram or screw installer that moves along tracks, which requires two workers. Soil disturbance would be restricted to the hydraulic ram/ screw machinery, about the

size of a small tractor, temporarily disturbing soil at each pile insertion location and while driving between drilling locations.

The remainder of the tracking rack system will be installed by construction crews using hand tools and all-terrain tracked equipment to distribute materials. Array racking will be bolted on top of the foundation piling to create a “rack” to which the solar panels can be fastened.

During array and racking assembly, multiple crews and various types of vehicles will be working within the Project Area. To the extent practicable, vehicular traffic will be limited to permanent and temporary access roads to minimize soil disturbance, mixing and compaction. These vehicles include flatbed trucks for transporting array components, small all-terrain vehicles, and pick-up trucks used to transport equipment and workers throughout the Project Area. Panels will be staged in advance throughout the Project Area and be brought to specific work areas for installation by wagon-type trailers pulled by small tractors or by all-terrain tracked equipment. The solar panels will be installed by multiple crews using hand tools. Installation crews will proceed in serpentine fashion along staked temporary access roads in a pre-established route to minimize off-road traffic.

### **2.3.5 Electrical Collection System**

As noted in Section 2.2.2, the collection system will either be installed in a below-ground system or hybrid above-ground/below-ground system. This technology is rapidly evolving and may be site-specific depending on geotechnical analysis, constructability, and availability of materials. Final engineering and procurement will help determine the construction method for the electrical collection system.

Below-ground AC collection systems will be installed in trenches or ploughed into place at a depth of at least four feet below grade using trenching machine or excavator. The trencher will cut an exposed trench approximately 1 foot wide by 4 feet deep.

Within the security fence, cables will be installed to a depth of 4 feet; outside of the security fence, cables would be at least 5 feet below ground. Topsoil will be stripped from the trenched area up to a maximum depth of 12 inches using a small backhoe and would be temporarily stored adjacent to the trench. Similar to the pile drivers used to install the racking, the soil disturbance from the trenching machines would be restricted to the trenching machine tracks only. This machine is the size of a small tractor. Once cables are installed, the trenches would be backfilled using a small, rubber tire or tracked backhoe and compaction equipment. Topsoil would be replaced to the restored trench line, and the pre-construction contour would be re-established using a small front-end loader.

If a hybrid option is selected and above-ground cabling is utilized, the DC collection cables will be strung under each row of panels on steel arms and a steel cable attached to the piles. At the end of each row, hanging brackets would connect several racks/rows of cables to a common collection point near their assigned inverter/transformer skid where the cables will be routed below-ground at a minimum depth of at least four feet below grade to the inverter/transformer skid where the current is converted to AC and voltage is stepped up to 34.5 kV. From the inverter/transformer skid, the AC collection would be installed below ground to the Project substation, as described above for the below-ground collection system.

BMPs that will be used during these earthmoving activities are described in detail in Section 3.

### **2.3.6 Inverter Installation**

The inverters units will be placed on frost-footing supported concrete pads or driven/helical screw pier foundations that will be designed to specifications necessary to meet the local geotechnical conditions. Topsoil will be removed and will be stored at suitable pre-established locations and graded to facilitate revegetation. Underground conduit and junction boxes will be installed throughout the Project to facilitate required cabling connecting equipment. Premanufactured skids with inverter, transformer and SCADA equipment may be used. These arrive by typical flat-bed trailer and truck and are set in place by a Rough-terrain hydraulic crane.

### **2.3.7 Project Substation Construction**

Construction work within the substation site will include site preparation and installation of substructures and electrical equipment. Installation of concrete foundations and embedments for equipment will require the use of trenching machines, concrete trucks and pumpers, vibrators, forklifts, boom trucks, and large cranes. Above-ground and below ground conduits from this equipment will run to a control enclosure that will house the protection, control, and automation relay panels. A station service transformer will be installed for primary AC power requirements. Batteries and battery chargers will be installed inside the enclosure for auxiliary power to the switchyard's control system. Crushed rock will cover the area of the substation and adequate lighting will be installed around the substation for worker safety during construction and operation.

One of two methods will be used to install substation foundations. Option 1 would be to use a small rubber tire backhoe to dig out major foundations prior to pouring the concrete slabs. Option 2 would use an auger/drill type machine for minor foundations.

In both scenarios, the limit of disturbance will be within the footprint of the substation for both the foundation equipment and the concrete delivery trucks. BMPs that will be used during these earthmoving activities are described in detail in Section 3. All topsoil from the Substation footprint will be removed up to a maximum depth of 12 inches to a pre-established suitable location for storage. The storage area would be near the site where the soil was removed, accurately located (GPS boundary, soil depth) and graded to facilitate revegetation. Subsoil would be removed to an acceptable preestablished and approved area for storage. After decommissioning, subsoil would be returned to the area from which it was excavated (as needed), topsoil would be replaced, and the area would be brought back to pre-construction contours.

### **2.3.8 Stormwater Drainage Bains**

Similar to Project substation construction described above, drainage basins would have topsoil removed and temporarily stored in a pre-established suitable location. Subsoil would then be excavated to a depth of four to seven feet and the sides of the drainage basin sloped to design, including inlet/outlet. Excavated subsoil would be distributed throughout the site as fill material in areas where grading is required. Topsoil would be replaced and the basins vegetated with a wet seed mix.

### **2.3.9 Generator-Tie Line Construction**

Given the proximity of the Magnolia Substation and the proposed Project substation, a 161-kV gen-tie line of less than 1,500 feet will be required.

### **2.3.10 Project Fencing Installation**

A fencing company will be contracted to construct the perimeter fencing around the Project. The fencing will consist of an agricultural woven wire fence and will extend approximately 6 feet above grade. At the request of MNDNR, barbed wire will not be used around the perimeter of the Project, and instead one foot of 3-4 strands of smooth wire will be used for a total height of approximately 8 feet above grade. However, the fencing around the substation will be a 6-feet above grade chain-link fence and include 1 foot of barbed wire to comply with the National Electric Code. Additional gates will be strategically installed at corners for deer egress and contact information for the site manager will be posted at the gates. The wooden posts for the agricultural fence will be augured or directly embedded, set in place, and backfilled with the soil that was displaced by the auger, if necessary. Chain link posts around the Project substation will be spaced at 10 feet on center. Corner posts will be augured 3.5 feet and embedded in concrete for structural support. All tangent posts will be direct buried 3.5 feet similar to corner posts. The Site will have man doors and gates installed, as needed.

## 3.0 LIMITATIONS AND SUITABILITY OF SITE SOILS

---

Soil varies considerably in its physical and chemical characteristics that strongly influence the suitability and limitations that soil has for construction, reclamation, and restoration. Major soil properties include:

- Soil texture
- Drainage and wetness
- Presence of stones, rocks, and shallow bedrock
- Fertility and topsoil characteristics
- Soil slope

Interpretative limitations and hazards for construction and reclamation are based to a large degree on the dominant soil properties, and include:

- Prime farmland status
- Hydric soil status
- Susceptibility to wind and water erosion
- Susceptibility to compaction
- Fertility and Plant Nutrition
- Drought susceptibility and revegetation potential

### 3.1 Land Use Considerations

Based on an air photo history, virtually all of the 2023 Land Control Area has been in agriculture starting prior to 1938, with several hundred acres of wet areas converted to agriculture by subsurface tile drainage. Most of the agricultural land is prime farmland or prime farmland if drained. Typically, high value crops such as corn and soybean rotations are grown in the area. Elk Creek assumes that all subsurface and surface drainage systems will be maintained during Project operation, and that upon decommissioning, all surface infrastructure will be removed and the land will be restored to agriculture.

### 3.2 Important Soil Characteristics

The Soil Survey Geographic Database (SSURGO) is the digitized county soil survey and provides a GIS relating soil map unit polygons to component soil characteristics and interpretations. Soil map unit polygons in the SSURGO database were clipped to the Project and internal infrastructure boundaries, including the major pieces of infrastructure:

- Fenced area hosting solar panels, racks, and arrays
- Inverter locations
- Access roads
- Laydown areas
- Project substation and O&M building

The acreage of major Project features sharing physical properties, classifications, and limitation interpretations important for construction, use, revegetation, and reclamation were determined by

spatial query of the GIS. Soils within the 1,521.5-acre 2023 Land Control Area but not anticipated to be affected by construction or operations are indicated in tables but not included in the following analysis, which only includes the 1,161.3 acres that will be affected by construction (2023 Preliminary Development Area).

A soil map of the 2023 Land Control Area is provided along with a table of selected characteristics of site soils including physical properties, classifications, and construction-related limitations in Appendices A and B.

### **3.2.1 Selected Physical Characteristics: Texture, Slope, Drainage and Wetness, Topsoil Depth, Bedrock and Presence of Stones and Rocks**

There are approximately 1,521.5 acres within the 2023 Land Control Area. Selected physical characteristics of site soils are broken down by acreage within the 1,161.3-acre 2023 Preliminary Development Area and the 360.3-acre undisturbed area in Table 1.

Soil texture affects water infiltration and percolation, drought tolerance, compaction, rutting, and revegetation among other things. Soil texture is described by the soil textural family which indicates the range of soil particle sizes averaged for the whole soil. 97.3 percent of the soils within the 2023 Preliminary Development Area (1,130.2 acres) are in the Fine Silty (1,019.5 acres, 87.8 percent) and Fine Loamy (110.7 acres, 9.5 percent) textural families, indicating medium-textured soils dominated by soil particles in the loam and silt fractions (between 0.002 and 3 mm) with fewer particles in the clay (<0.002 mm) and sand (>2 mm) fractions. Medium-textured soils typically have good physical and available-water characteristics to support plant growth if not in excessively steep or wet conditions. They have high water-holding capacity, with most of the water being readily available for plant growth.

Slope affects constructability, water erosion, revegetation, compaction and rutting, among other properties. Nearly all of the soils (1,157.7 acres, 99.7 percent) within the 2023 Preliminary Development Area are nearly level soils with representative slopes falling within the 0-5 percent slope range.

Soil drainage indicates the wetness in the soil profile along with the speed at which internal water moves. Soil Drainage affects constructability, erosion by wind and water, and revegetation success. Most of the soils within the 2023 Preliminary Development Area are in the moderately well and somewhat poor drainage classes (410.8 and 309.9) acres, respectively, cumulatively 62 percent of the 2023 Preliminary Development Area acreage), with smaller areas mapped into Well (167.9 acres, 14 percent) and Poor (272.7 acres, 23 percent) drainage classes. None of the soils are excessively drained that would be subject to drought. Soils in Somewhat Poor and Poor drainage classes are highly productive when drained and are frequently converted to agriculture by the installation of subsurface drain tile. Virtually all of the soils in Somewhat Poor and Poor drainage classes in the 2023 Preliminary Development Area have been drained. Moderately well and somewhat poorly drained soils typically are not droughty or wet and are typically well suited to intensive agriculture.

**Table 1: Acreage of Soils with Selected Physical Characteristics by Project Feature within the 2023 Land Control Area (Total 1,521.5 acres)**

Project Feature	Total Acres <sup>1</sup>	Textural Family <sup>2</sup>				Slope Range <sup>3</sup>		Drainage Class <sup>4</sup>					Topsoil Thickness <sup>5</sup>			Shallow Bedrock / Stony <sup>6</sup>
		Fine Loamy	Fine Silty	Fine-Silty over Sandy	Sandy	0-5	>8-15	SWE	W	MW	SWP	P	>6 - 12	>12 - 18	>18	
Acres																
Preliminary Development Area (Potential Disturbance)																
Fence Area/Arrays	1,080.5	106.1	947.2	27.3	--	1,077.1	3.4	--	159.4	395.2	292.1	233.8	20.2	463.0	597.3	--
Access Roads	22.1	2.2	19.1	0.8	--	22.1	--	--	3.7	7.9	5.5	5.0	0.4	8.8	12.9	--
Inverters	0.3	0.0	0.2	0.0	--	0.3	--	--	0.0	0.1	0.1	0.0	0.0	0.1	0.1	--
Laydown Yards	11.2	0.7	10.5	--	--	11.2	--	--	--	5.1	3.1	3.0	--	6.0	5.3	--
O&M building/Sub-station	1.5	--	1.5	--	--	1.5	--	--	--	1.0	0.5	0.0	--	1.0	0.6	--
Collection	1.4	0.1	1.4	--	--	1.4	--	--	--	0.3	0.4	0.8	--	0.3	1.1	--
Stormwater Basins	44.2	1.7	39.5	3.1	--	44.0	0.2	--	4.8	1.2	8.2	30.1	0.3	6.3	37.6	--
<b>Subtotal</b>	<b>1,161.3</b>	<b>110.7</b>	<b>1,019.5</b>	<b>31.1</b>	<b>0.0</b>	<b>1,157.7</b>	<b>3.6</b>	<b>0.0</b>	<b>167.9</b>	<b>410.8</b>	<b>309.9</b>	<b>272.7</b>	<b>20.9</b>	<b>485.5</b>	<b>654.9</b>	<b>0.0</b>
Land Under Control but Not Currently Planned for Development																
Undisturbed	360.3	117.5	215.6	17.9	9.2	359.8	0.4	9.2	58.7	60.9	72.0	159.5	27.1	108.4	224.7	0.0
Grand Total																
<b>Grand Total</b>	<b>1,521.5</b>	<b>228.2</b>	<b>1,235.1</b>	<b>49.0</b>	<b>9.2</b>	<b>1,517.5</b>	<b>4.0</b>	<b>9.2</b>	<b>226.6</b>	<b>471.7</b>	<b>381.9</b>	<b>432.2</b>	<b>48.1</b>	<b>593.9</b>	<b>879.6</b>	<b>0.0</b>
<sup>1</sup>	Total acres of Project features that are anticipated to be disturbed by supporting construction equipment traffic, excavation, and grading. Data obtained by merging Project facility polygons with the SSURGO spatial data in ArcGIS. Summations were performed in Microsoft <sup>™</sup> Access.															
<sup>2</sup>	Data available directly from the Natural Resources Conservation Service (NRCS) SSURGO spatial or attribute database via geospatial query of the spatial or attribute data.															
<sup>3</sup>	Representative slope values are taken directly from the SSURGO database. The SSURGO database provides representative slope values for all component soil series. Slope classes represent the slope class grouping in percent that contains the representative slope value for a major component soil series. For example, a soil mapped in the 2-6% slope class has an average slope of 4%, which is within the 0-5% slope range.															
<sup>4</sup>	Drainage class as taken directly from the SSURGO database. (SWE – Somewhat excessively drained; W – Well drained; MW – Moderately well drained; SWP – Somewhat poorly drained; P – Poorly drained)															
<sup>5</sup>	Topsoil thickness is the aggregate thickness of the A horizons described in the SSURGO database.															
<sup>6</sup>	Depth to bedrock taken directly from the SSURGO database. Stony/Rocky soils are those soils that have either a cobbly, stony, boulder, shaly, very gravelly or extremely gravelly modifier to the textural class of the surface layer or that have a surface layer with > 5% stones or rocks > 3 inches in any dimension.															



Topsoil depth affects soil plant nutrition and surface soil structure. To maintain soil productivity, soils with thick topsoil will require larger areas for storage of larger volume of topsoil stripped from permanent infrastructure footprints such as permanent access roads, inverters, and the Project substation. Most of the soils within the 2023 Preliminary Development Area are Mollisols and are characterized by the presence of relatively thick topsoil greater than 12 inches in depth (1,140.4 acres, 98 percent).

The presence of bedrock near the soil surface and rocks and stones in the soil profile affects constructability and revegetation. No soils in the 2023 Preliminary Development Area are shallow to bedrock or have stones at the soil surface or within the soil profile.

### **3.2.2 Selected Classification Data: Prime Farmland, Land Capability Classification, Hydric Soils.**

Selected classification information for site soils are broken down by acreage within the 1,161.3 - acre 2023 Preliminary Development Area and the 360.3-acre undisturbed area in Table 2.

Natural Resources Conservation Service (NRCS)-designated prime farmland soils have the best combination of physical and chemical characteristics for producing food, feed, forage, fiber, and oilseed crops and are also available for these uses<sup>2</sup>. Nearly all of the soils in the 2023 Preliminary Development Area are classified into prime farmland, prime farmland if drained or prime farmland if protected from flooding or not frequently flooded during the growing season (885.0, 256.6 and 2.7 acres respectively; cumulatively 98.5 percent).

The NRCS also recognizes farmlands of statewide importance, which are defined as lands other than prime farmland that are used for production of specific high-value food and fiber crops (e.g., citrus, tree nuts, olives, fruits, and vegetables). Farmlands of statewide importance have the special combination of soil quality, location, growing season, and moisture supply needed to economically produce sustained high quality or high yields of specific crops when treated and managed according to acceptable farming methods. Farmland of statewide importance is similar to prime farmland but with minor shortcomings such as greater slopes or less ability to store soil moisture. 3.6 acres (0.3 percent) of soils within the 2023 Preliminary Development Area are classified as farmland of statewide importance.

Land Capability Class (LCC) is a system of grouping soils primarily on the basis of their capability to produce common cultivated crops and pasture plants without deteriorating over a long period of time. Soils within the 2023 Preliminary Development Area are in LCC 1, 2e, 2s 2w, 3e and 5w. A numerical value of 1 and 2 indicates soils with no or few limitations that restrict the choice of plants or require moderate management; a numerical value of 3 indicates soils with severe limitations that reduce the choice of plants or require special conservation practices, or both; a numerical value of 5 indicates soils with little or no hazard of erosion, but that have other limitations that limit their use mainly to pasture, rangeland, forestland or wildlife habitat. Soils in LCC classes 1 and 2e are typically considered prime farmland and soils in LCC class 2W are

---

<sup>2</sup> [prime farmland] has the combination of soil properties, growing season, and moisture supply needed to produce sustained high yields of crops in an economic manner if it is treated and managed according to acceptable farming methods. In general, prime farmland has an adequate and dependable water supply from precipitation or irrigation, a favorable temperature and growing season, an acceptable level of acidity or alkalinity, an acceptable content of salt or sodium, and few or no rocks. Its soils are permeable to water and air. Prime farmland is not excessively eroded or saturated with water for long periods of time, and it either does not flood frequently during the growing season or is protected from flooding.

considered prime farmland if drained. Most of the soils in the Project site (1,137.4 acres, 98 percent) are in LCC 1, 2e, and 2w. Those soils with wetness limitations have been converted to prime farmland status by drainage.

Hydric soils are generally described as soils in poorly drained to very poorly drained drainage classes. Hydric soils are formally a component of regulated wetlands and can be used to indicate areas with potential jurisdictional wetlands. Most of the soils are non-hydric (846.7 acres, 77 percent), with 272.7 acres (23 percent) being considered hydric soils. Virtually all of the hydric soils that were historic wetlands have been legally converted to non-wetland by subsurface tile drainage.

<b>Table 2: Acreage of Soils with Selected Classification Data by Project Feature Within the 2023 Land Control Area (Total 1,521.5 acres)</b>												
Project Feature	Total Acres <sup>1</sup>	Prime Farmland <sup>2</sup>			Farmland of Statewide Importance	Land Capability Class <sup>2</sup>						Hydric Soil <sup>2</sup>
		All Soils	If Drained	If Protected		1	2e	2s	2w	3e	5w	
Acres												
Preliminary Development Area (Potential Disturbance)												
Fence Area/Arrays	1,080.5	843.3	219.7	1.9	3.4	336.0	501.8	5.5	221.6	3.4	12.2	233.8
Access Roads	22.1	17.1	4.8	0.1	-	6.3	10.3	0.5	4.9	-	0.1	5.0
Inverters	0.3	0.2	0.0	-	-	0.1	0.2	-	0.0	-	-	0.0
Laydown Yards	11.2	8.3	2.3	0.7	-	3.1	5.1	-	3.0	-	-	3.0
O&M/Substation	1.5	1.5	0.0	-	-	0.5	1.0	-	0.0	-	-	0.0
Collection	1.4	0.7	0.7	-	-	0.4	0.3	-	0.7	-	0.1	0.8
Stormwater Basins	44.2	13.9	28.9	-	0.2	9.5	3.6	0.8	28.9	0.2	1.1	30.1
<b>Sub-Total</b>	<b>1,161.3</b>	<b>885.0</b>	<b>256.6</b>	<b>2.7</b>	<b>3.6</b>	<b>336.0</b>	<b>501.8</b>	<b>5.5</b>	<b>221.6</b>	<b>3.4</b>	<b>12.2</b>	<b>272.7</b>
Land Under Control but Not Currently Planned for Development												
Undisturbed	360.3	191.2	85.6	15.2	9.6	78.0	110.8	2.3	100.8	9.6	58.7	159.5
<b>Grand Total</b>												
<b>Grand Total</b>	<b>1,521.5</b>	<b>1,076.1</b>	<b>342.2</b>	<b>17.9</b>	<b>13.2</b>	<b>434.0</b>	<b>633.1</b>	<b>9.1</b>	<b>360.1</b>	<b>13.2</b>	<b>72.1</b>	<b>432.2</b>
<sup>1</sup> Total acres of Project features that are anticipated to be disturbed by supporting construction equipment traffic, excavation, and grading. Data obtained by merging facility polygons with the SSURGO spatial data in ArcGIS. Summations were performed in Microsoft <sup>™</sup> Access. <sup>2</sup> Data available directly from the NRCS SSURGO spatial or attribute database via geospatial query of the spatial or attribute data.												

### 3.2.3 Construction-Related Interpretations: Highly Erodible Land (Wind and Water), Compaction Prone, Rutting Prone, and Drought Susceptible with Poor Revegetation Potential.

Selected construction-related interpretative data for site soils are broken down by acreage within the 1,161.3-acre 2023 Preliminary Development Area and the 360.3-acre undisturbed area in Table 3.

<b>Table 3: Acreage of Soils in Selected Construction-related Interpretations by Project Feature Within the 2023 Land Control Area (Total 1,521.5 acres)</b>								
Project Feature	Total Acres <sup>1</sup>	Highly Erodible <sup>2</sup>		Compact. Prone <sup>3</sup>	Rutting Hazard <sup>4</sup>			Drought Susceptible <sup>5</sup>
		Water	Wind		Severe	Moderate	Slight	
Acres								
Preliminary Development Area (Potential Disturbance)								
Fence Area/Arrays	1,080.5	3.4	-	525.9	1,080.5	-	-	-
Access Roads	22.1	-	-	10.5	22.1	-	-	-
Inverters	0.3	-	-	0.1	0.3	-	-	-
Laydown Yards	11.2	-	-	6.1	11.2	-	-	-
O&M/Substation	1.5	-	-	0.6	1.5	-	-	-
Collection	1.4	-	-	1.1	1.4	-	-	-
Stormwater Basins	44.2	0.2	-	38.3	44.2	-	-	-
<b>Subtotal</b>	<b>1,161.3</b>	<b>3.6</b>	<b>0.0</b>	<b>582.6</b>	<b>1,161.3</b>	<b>0.0</b>	<b>0.0</b>	<b>0.0</b>
Land Under Control but Not Currently Planned for Development								
Undisturbed	360.3	0.4	-	231.5	351.0	9.2	-	9.2
<b>Grand Total</b>								
<b>Total</b>	<b>1,521.5</b>	<b>4.0</b>	<b>0.0</b>	<b>814.1</b>	<b>1,512.3</b>	<b>9.2</b>	<b>0.0</b>	<b>9.2</b>
<sup>1</sup>	Total acres of Project features that are anticipated to be disturbed by supporting construction equipment traffic, excavation, and grading. Data obtained by merging facility polygons with the SSURGO spatial data in ArcGIS. Summations were performed in Microsoft <sup>™</sup> Access.							
<sup>2</sup>	Highly Erodible Water includes soils in Land Capability Class 4e through 8e or that have a representative slope value greater than or equal to 9%. Highly Erodible Wind Includes soils in wind erodibility groups 1 and 2.							
<sup>3</sup>	Includes soils that are somewhat poorly drained to very poorly drained soils in loamy sands and finer textural classes.							
<sup>4</sup>	Ratings are based on depth to a water table, rock fragments on or below the surface, the Unified classification of the soil, depth to a restrictive layer, and slope. The hazard is described as slight, moderate, or severe. A rating of "slight" indicates that the soil is subject to little or no rutting. "Moderate" indicates that rutting is likely. "Severe" indicates that ruts form readily.							
<sup>5</sup>	Includes soils with a surface texture of sandy loam or coarser that are moderately well to excessively drained.							

Highly erodible land is identified as being susceptible to water and wind erosion. The majority of soils in the 2023 Preliminary Development Area are low relief, medium-textured soils with intermediate water infiltration characteristics that limit soil erosion by the agent of water. Less than 1 percent of the 2023 Preliminary Development Area has soils that are highly water erodible.

Wind erosion was evaluated using the wind erodibility group. Highly wind erodible soils are medium textured, relatively well drained soils with poor soil aggregation, resulting in soils with soil surfaces dominated by particles that can be dislodged and carried by the wind. None of the soils within the 2023 Preliminary Development Area are considered highly wind erodible.

Soils prone to compaction and rutting are subject to dramatic and adverse changes in soil porosity and structure as a result of mechanical deformation caused loading by equipment during construction. Compaction and rutting are related to moisture content and texture and are worse when medium- and fine-textured soils are subject to heavy equipment traffic when wet. Compaction and rutting are anticipated on 582.6 acres (50 percent) and 1,161.3 acres (100 percent), respectively, if they are trafficked when wet. Elk Creek will develop prescriptions that avoid trafficking soils when wet to avoid and minimize potential compaction and rutting.

Soils susceptible to drought include coarse textured soils in moderately well to excessive drainage classes. Revegetation during seed germination and early seedling growth is severely compromised during dry periods on droughty soils. None of the soils within the 2023 Preliminary Development Area are susceptible to drought.

### **3.2.4 Summary of Major Soil Limitations at the Elk Creek Solar Project**

#### **3.2.4.1 Prime Farmland**

Soils within the Elk Creek 2023 Land Control Area are nearly level, deep, moderately drained, medium-textured Mollisols. Nearly all of the soils within the 2023 Land Control Area are prime farmland. The primary limitations for the soils during construction, operations and maintenance, and decommissioning include compaction and rutting that may occur when the soils are trafficked when wet, and the need to reserve and store large volumes of topsoil.

While soils classified as prime farmland will be impacted by the solar facility, Elk Creek will implement BMPs during construction detailed in Section 4.0 including soil segregation and decompaction, wet weather conditions, erosion and sediment control. After construction, and for the life of the Project, soils will be stabilized and soils given an opportunity to rest, as the site is revegetated with a permanent cover of prairie grasses according to seeding and management specifications agreed to between Elk Creek and the MNDNR to the benefit of wildlife and the soil. Upon decommissioning, the land could be returned to its pre-construction agricultural use or to another use if the economic conditions at that time indicated another use is an appropriate use for the site. Elk Creek anticipates that the property will be restored to agricultural use on decommissioning of the Project.

Initial post-construction revegetation efforts and maintenance of vegetation during operations and maintenance will consider selecting suited plants, managing seeding times for late spring early summer when soil moisture is optimum for germination, use of mulch and other BMPs. Existing tile drainage systems will be maintained during Project operations. The only impact to prime farmland is that the land will not be farmed for the life of the Project, approximately 30 years.

### **3.2.4.2 Topsoil Storage**

Topsoils are thick ranging from 12 to greater than 18 inches, relatively high in organic matter, and fertile. Storing topsoil in relatively sterile, large piles that are not active plant growth media is not recommended as the storage conditions may adversely influence soil flora and fauna affecting soil quality when topsoils are restored to areas from which the topsoil was taken. To the extent practicable, topsoil should be conserved by preselecting areas to receive excess topsoil from nearby areas, grading and seed bed preparation as appropriate, and revegetation to maintain a rhizosphere suitable for plant growth.

### **3.2.4.3 Compaction and Rutting**

Compaction and rutting are potential limitations in the 2023 Preliminary Development Area. Elk Creek will design construction access and manage construction passes to minimize the number of trips occurring on a given soil and will implement wet weather procedures any time that rutting is observed. Deep compaction is not anticipated to be a significant problem as the number of construction equipment passes over a given area is limited, and construction equipment consists of smaller, low-ground-pressure tracked vehicles.

## 4.0 BMPs DURING CONSTRUCTION AND OPERATION

---

The Project will be constructed and operated on property owned or leased by Elk Creek. As stated above, the Project is located on highly productive farmland occupying a flat to gently rolling loess-covered till plain in southwestern Minnesota.

Because all construction activities will be limited to land owned or leased by Elk Creek, no direct impacts to adjacent land are expected. Additionally, the technology to be deployed at this facility does not require that the entire Project Site be completely flat or a uniform grade. Because most of the Project site is currently nearly level or has slightly rolling terrain (Table 1), the amount of grading anticipated within the 2023 Preliminary Development Area is expected to be minimal. The PV arrays can be designed to follow the existing grade of the Project Site within certain tolerances, which allows the designer of the facility to minimize the amount of earthmoving activities that are required (see Figures 3 and 4).

While some grading activities may be required to raise or lower certain areas within the Project Site, the majority of the Project Site's topography would be left unchanged. The remainder of earthmoving activities would consist of work on the interior access roads, trenches for the DC and AC collection system, and foundational work for the Project substation and inverter skids, as necessary. The sections below describe the measures that the Contractor will implement to minimize the physical impacts to the integrity of the topsoils and topography of the Project Site.

### 4.1 Environmental Monitor

Elk Creek will contract with a third-party to monitor earthmoving and trenching activities during the initial phase of Project construction to ensure appropriate measures are taken to properly segregate and handle the topsoils. Elk Creek will coordinate with MDA to identify a suitable environmental monitor (Monitor). The Monitor will have a variety of duties, including but not limited to:

- Perform weekly inspections during the major earthmoving phase of Project construction;
- observe construction crews and activities to ensure that topsoil is being segregated and managed appropriately;
- monitor the site for areas of potential soil compaction (except within access roads) and make specific recommendations for decompaction;
- make recommendations to Elk Creek's construction manager;
- assist in determining if weather events have created "wet weather" conditions and provide recommendations to the construction manager on the ability to proceed with construction; and
- submit a report of Elk Creek's adherence to soil BMPs to MDA on a weekly basis during the major earthmoving phase of Project construction and upon completion of earthmoving activities.

Potential issues with BMPs will be reported to Elk Creek's construction manager and to MDA. The construction manager will use discretion to either correct the activity or stop work.

## 4.2 Soil Segregation and Decompaction

During construction, one of the primary means to protect and preserve the topsoil at the Project Site will be to separate the topsoil from the other subgrade/subsoil materials when earthmoving activities or excavation are taking place during grading, road construction, cable installation, foundation installation, etc. There may be limited situations where excavated subsoil must be stored on adjacent undisturbed topsoil. In these situations, subsoil will be returned to the excavation with as little disturbance of the underlying topsoil as practicable. Laying down a thin straw mulch layer as a buffer between the subsoil and topsoil may be used as practicable to facilitate more effective separation of the subsoil and underlying topsoil during the excavation backfill process.

Based on SSURGO data, topsoil thickness is typically over 12 inches. This will be confirmed with tests by a Minnesota Licensed Professional Soil Scientist prior to earthwork activities on the site. Elk Creek will work with the soil scientist to identify the appropriate depth of topsoil that should be stripped and segregated from other subsoil materials during earthwork activities. Elk Creek will provide this information and a recommendation on specific segregation methods/techniques to the Monitor for review and input. As an interim recommendation Elk Creek suggests that the full depth of topsoil be stripped up to 12 inches in thickness. Topsoil greater than 12 inches from the soil surface would be treated similarly to the underlying subsoil. During the activities that require temporary excavations and backfilling (i.e., trenching activities) the subgrade material will be replaced into the excavations first and compacted as necessary, followed by replacement of topsoil to the approximate locations from which it was removed. Topsoil will then be graded to the approximate pre-construction contour<sup>3</sup>. Elk Creek will strive to avoid compaction in other areas where it is not required by the design.

Following earthwork activities that require segregation of topsoils/subsoils, topsoil materials will be re-spread on top of the backfilled and disturbed areas to maintain the overall integrity and character of the pre-construction farmland. Any excess topsoil material would be re-spread on the Project Site at pre-established locations on the site. The location and amount of topsoil will be documented to facilitate re-spreading of topsoil after decommissioning. This practice is described in more detail below for each of the earthmoving activities that are anticipated for this Project.

## 4.3 Wet Weather Conditions

During the construction of the Project, it is likely that there will be periods of wet weather that may necessitate a temporary halt of construction activities. The Elk Creek Construction Manager will have responsibility for halting activities if weather conditions pose a risk to worker safety or if conditions are such that heavy equipment would cause severe rutting of the Project Site. Following initial grading at the Site, many activities could still proceed in wet weather given the lack of heavy equipment required for those tasks. However, Elk Creek's Construction Manager would be responsible for ensuring that topsoil erosion, rutting, compaction, or damage to drain tiles (as present) is avoided or minimized to the extent possible. Because compaction of soils can

---

<sup>3</sup> Elk Creek recognizes that topsoil mixing is both an aesthetic and crop-productivity issue and will strive to minimize to the extent practicable topsoil and subsoil mixing during initial construction, operations, and decommissioning/reclamation. For the purpose of identifying areas where topsoil mixing is a problem, the Environmental Monitor will consider topsoil storage piles, restored trench excavations, and post-closure restored areas with > 5% area of the soil surface as obvious subsoil inclusions to be out of compliance. Remediation may consist of removal of subsoil and replacement with acceptable topsoil.



become problematic during wet weather conditions, as stated above, the Construction Manager will work with the soil scientist and the Monitor to ensure that techniques/practices are employed to decompact soils appropriately following wet weather conditions. Decompaction with chisel plows prior to disking and planting will typically be a standard method of soil preparation in areas proposed for seeding to native grasses, forbs, and pollinator species. Agricultural equipment capable of operating within the approximate 20-foot wide space between panel lines when panels are oriented vertically would be used to decompact, prepare a seedbed, and plant suited seed mixes.

#### **4.4 Adaptive Management During Construction**

Should weather or site conditions during construction require different BMPs than those that are described in this section, Elk Creek will work with the Monitor, MDA and other appropriate agencies to discuss potential new approaches to the specific conditions that are encountered.

Elk Creek will remain flexible and implement new practices/procedures that will help ensure the quality of the land while maintaining the safety of the workers.

#### **4.5 Initial Grading/Road Construction/Array Construction**

The first phase of Project construction will be the general civil works at the Project Site where all major cut and fill activities will be performed by the Contractor. As stated above, Elk Creek Solar will consult with a qualified soil scientist to identify the appropriate depth of topsoil up to 12 inches that should be stripped and segregated from other materials during initial grading activities. Based on discussions with MDA, topsoils in this region of Minnesota may reach depths of 3-feet. This will be confirmed with tests by the soil scientist prior to grading activities. Elk Creek Solar will provide this information and a recommendation on specific segregation methods/techniques to the MDA for review and input.

The Contractor will first strip topsoil around the few selected hills/valleys on site. This will ensure that the topography falls within the tolerances allowed for by the solar array design. During this civil work, topsoil will be pushed outside of the cut/fill areas and collected into designated spots for later use. Once topsoil is removed from the cut/fill areas, the sub-grade materials will be removed as required from on-site hills and relocated to on-site low spots. Prior to relocating sub-grade materials to the low spots, topsoil in the low areas will be stripped and set aside before the fill is added, then respreads over the new fill. The sub-grade materials would be compacted in place. When compaction is complete, the topsoil spoil piles will be re-spread over the reconditioned sub-grade areas. See footnote 3 for information on identifying topsoil/subsoil mixing when and where it occurs.

This newly spread topsoil will be loosely compacted and/or “tracked” and employ the wind and stormwater erosion prevention BMPs described below in Section 4.8.

After the majority of the major earthwork activities have been completed, the Contractor will start construction of the internal road network. This work would start with the stripping of topsoil materials from the 16-foot-wide roadbeds to a depth of at least 12 inches. Topsoil will be windrowed to the edges of each roadbed. Windrowing will consist of pushing materials into rows of spoil piles adjacent to the road which will be loosely compacted and/or “tracked” with

stormwater and wind erosion BMPs in place. The Contractor will then compact the sub-grade materials. As discussed in Section 2.3.3, after gravel is installed and compacted to engineers' requirements, the Contractor will shape Project drainage ditches as identified on the final grading plan. Finally, the previously stripped and windrowed topsoil material will be re-spread throughout the 2023 Preliminary Development Area.

Once grading and road construction is complete, the Contractor can begin the installation of foundation piles for the PV array racking system. This work will consist of directly driving the pile into the soil with pile hammers. These vehicles would operate on the existing surface of the ground and impacts would be limited to what is typical when vehicles drive over the soil surface. Very little soil disturbance is expected from this activity.

## 4.6 Foundations

The Contractor will also perform foundation work for the Project substation and inverters. For the substation, the Contractor will strip topsoil off the substation area, install the pier-type foundations, compact sub-grade materials, re-grade spoils around the substation yard, and then install clean washed rock on the surface. All topsoil stripped from the substation area will be pushed outside of the substation area and collected into designated spots for later use. These topsoil piles will be windrowed or piled and loosely compacted and/or "tracked" with stormwater and wind erosion BMPs in place. Once substation construction is advanced, the topsoil piles would be distributed in a thin layer adjacent to the substation area.

For the inverters, topsoil will again be stripped and placed adjacent to the inverter. Afterwards, the foundations will be dug using a rubber-tire backhoe and then rebar and concrete installed and left to cure. After cure and testing of concrete strength is completed, the subgrade spoils will be compacted around the inverters. After the inverter is set, the adjacent topsoil will be re-spread around the inverter.

## 4.7 Trenching

Construction of the Project may require trenching for the installation of both DC and AC collection lines across the Project Area. If the collection lines are buried, the Contractor will be installing AC and DC collection cables in trenches of 4 feet deep using the "open trench" method. Topsoil and subgrade materials would be excavated from the trench using typical excavating equipment or backhoes and segregated as described above. The bottom of each trench may be lined with clean fill to surround the cables. Elk Creek anticipates that native subsoil will be rock free (Table 1), and that no foreign fill will be necessary. After cables have been installed on top of bedding materials in the trench, 1 foot of screened, native backfill will be placed on the cables followed by additional 2 feet of unscreened native backfill trench spoil. This material would be compacted as necessary. The last 1 foot of each trench will then be backfilled with topsoil material only to return the surface to its finished grade. See footnote 3 for information on identifying topsoil/subsoil mixing when and where it occurs.

## 4.8 Temporary Erosion and Sediment Control

Elk Creek Solar will prevent excessive soil erosion on lands disturbed by construction by adhering to a Stormwater Pollution Prevention Plan (SWPPP) required under the National Pollutant Discharge Elimination System (NPDES) permitting requirement that will be administered by the Minnesota Pollution Control Agency.

Prior to construction, Elk Creek will work with engineers or the Contractor to outline the reasonable methods for erosion control and prepare the SWPPP.

These measures would primarily include silt fencing on the downside of all hills, near waterways, and near drain tile inlets. This silt fencing would control soil erosion via stormwater. Check dams and straw wattles will also be used to slow water during rain events in areas that have the potential for high volume flow. In addition, the Contractor can use erosion control blankets on any steep slopes, although given the site topography, this BMP will not likely be required. Lastly, as outlined above, topsoil and sub-grade material will be piled and loosely compacted and / or “tracked” while stored. The BMPs employed to mitigate wind and stormwater erosion on these soil stockpiles will include installing silt fence on the downward side of the piles as needed and installation of straw wattles if these spoil piles are located near waterways.

The SWPPP will identify designated onsite SWPPP inspectors to be employed by the Contractor for routine inspections as well as for inspections after storm events per the plan outlined in the SWPPP.

## 4.9 Drain Tile Identification, Avoidance and Repair

Elk Creek Solar is aware of the presence of drain tile within the 2023 Land Control Area which appears to be adequately draining the Project Area and discharging primarily into the County managed ditches on the north and south ends of the proposed Project. To minimize unforeseen repairs or damages to existing drain tile and/or drain tile systems, Elk Creek Solar has developed a comprehensive plan to address the presence and treatment of this tile before, during, and after construction. The plan consists of the following components and each component is discussed in detail below:

- Pre-Construction Tile Mapping and Repair
- Project Design Considerations
- Construction Mitigation Measures
- Repair/Remediation of Damaged Tile

### 4.9.1 Pre-Construction Tile Mapping and Repair

Elk Creek Solar has contacted landowners and has secured drain tile maps for a majority of the 2023 Land Control Area and will continue to coordinate for mapping on remaining parcels. Elk Creek will continue to coordinate with landowners for mapping on the remaining parcels. In the event the remaining drain tile mapping cannot be identified, Elk Creek will utilize other sources, including infrared aerial photographs, LiDAR data, and, if necessary, a site-specific tile locate survey with a local agricultural drain tile contractor (Tile Contractor).

If necessary, physical location of drain tile will be performed by using a small excavator to dig a shallow trench perpendicular to and at varying intervals across areas where research indicated tile could be found.

Visible surface inlets will be identified and a tile probe inserted to locate the tile line and determine its direction from the inlet. Using an excavator, a shallow trench will be dug to confirm the presence of the tile. Once confirmed, a tile probe will locate the tile line to determine the direction of the tile. As necessary, appropriate tile lines will be exposed to determine size, type, flow direction, and condition. Any damaged tile encountered in the tile location process will be repaired or replaced to its original size and capacity.

Clogged tiles found during the location process will be assessed. Clogged tile is often an indication of a failing line tile. However, cleaning clogged tile is not usually cost effective and may lead to future problems, so a remediation plan is being developed to address clogged tile locations during the construction process. Remediation may involve replacing the clogged portion of tile or replacing the line completely.

In some locations within the 2023 Preliminary Development Area, existing tile lines may need to be relocated to avoid damage from Project facilities. In the event a tile line requires replacement, the new tile will have the capacity, depth, and appropriate slope to ensure the new tile line performs adequately for the line it is replacing. All replacement or rerouting of tile will take place proactively during construction or as it is identified in order to maintain the integrity of the drainage lines during construction. This practice should minimize interruption of any drainage on site or on any neighboring farms that may drain through the property.

Repairs or rerouting will be performing using a small to mid-sized excavator. Laser equipment will be used to ensure proper grading of the pipe. In the event a line of significant size and length needs to be rerouted or installed, a commercial drainage plow could be used.

The drainage plow typically utilizes GPS-grade control to ensure pipe is installed to specified slopes. The following considerations will also apply:

- Tiles will be repaired with materials of the same or better quality as that which was damaged.
- Tile repairs will be conducted in a manner consistent with industry-accepted methods.
- Before completing permanent tile repairs, tiles will be examined within the work area to check for tile that might have been damaged by construction equipment. If tiles are found to be damaged, they will be repaired so they operate as well after construction as before construction began.
- Elk Creek Solar will make efforts to complete permanent tile repairs within a reasonable timeframe, taking into account weather and soil conditions.

#### **4.9.2 Project Design Considerations**

By establishing an accurate assessment of the drain tile in the Project Site prior to construction, Elk Creek can overlay the location of the tile lines on their construction plans and identify any conflicts with the drainage lines. Following the location process, GIS layers and CAD files of tile

locations will be generated and provided to the solar array design engineer. The engineers will design around the tiles to ensure placement of the solar racking systems do not damage the tile to the extent feasible. In some areas, re-routing of the tile is necessary and this re-routing work will take place immediately prior to or during construction.

### **4.9.3 Construction Measures**

In areas where it will be impossible to design solar arrays around tile locations, steps will be taken to ensure the integrity of the drainage system will remain intact both during and after construction. Tile lines that are in direct conflict with solar array installation or trenches (i.e., collection lines) will be rerouted around the conflict area. Tile lines that have the potential to be damaged by construction traffic will be bridged or reinforced to maintain integrity.

### **4.9.4 Operational Measures**

Following completion of construction, Elk Creek Solar will inspect the Project Site after significant snow melt or rainfall events for evidence that tile systems are functioning adequately. If localized wet areas or standing water are observed, it is likely the tile system is not operating as anticipated. In this situation, the Tile Contractor will be reengaged to pin-point any damaged tile that may have been missed during construction. Tile would be repaired following the process outlines above.

## **4.10 Construction Debris**

Construction-related debris and unused material will be removed by Elk Creek Solar and the Contractor. Any below-grade, unusable materials will be removed and loaded immediately onto trucks for subsequent disposal at a designated off-site location. The Contractor will use locally sourced dumpsters and removal services to regularly check and schedule pick-ups for full dumpsters which will be switched out for empty ones. To the extent practicable, recyclable materials (i.e., cardboard) will be sorted and recycled at a local facility.

Debris/trash collection points and dumpsters will be located both in the laydown yards as well as at strategically designated locations close to where actual work is being performed. If loose debris fails to be deposited into dumpsters or if it becomes wind-blown, the Contractor will inspect and clear fence lines of debris on a daily basis to ensure that debris and trash does not leave the Project Area. Contaminated materials are not expected; however, if any such materials are encountered during construction, specialized dumpsters and handling instructions will be employed to suit the types of contaminated materials that are discovered. Contaminated materials will be disposed of at the nearest appropriate facility in accordance with applicable laws, ordinances, regulations, and standards.

## 5.0 DECOMMISSIONING

---

At the end of the Project's useful life, Elk Creek will either take necessary steps to continue operation of the Project (such as re-permitting and retrofitting) or will decommission the Project and remove facilities. Decommissioning activities will include:

- Removing the solar arrays, transformers, electrical collection system, fencing, lighting and substations, and possibly the O&M building (the O&M building may be useful for other purposes);
- Removal of below-ground electrical cables to a depth of four feet (cables buried below four feet will be left in place);
- Removal of buildings and ancillary equipment to a depth of four feet;
- Removal of surface road material and restoration of the roads to substantially the same physical condition that existed immediately before construction. If the Project is decommissioned and the land sold to a new owner, Elk Creek would retain any access roads the new landowner requested be retained;
- Grading, adding or re-spreading topsoil, and reseeded according to the Natural Resources Conservation Service (NRCS) technical guide recommendations and other agency recommendations, areas disturbed by the construction of the facility or decommissioning activities, grading and soil disturbance activities will be kept to the minimum necessary to restore areas where topsoil was stripped in construction, topsoil in decommissioned roads and compaction only in areas that were compacted during decommissioning activities so that the benefits to the soil that were achieved over the life of the Project are not counteracted by decommissioning; and
- Standard decommissioning practices would be utilized, including dismantling and repurposing, salvaging/recycling, or disposing of the solar energy improvements, and restoration.

### 5.1.1 Timeline

Decommissioning is estimated to take 13 months to complete and the decommissioning crew will ensure that all equipment is recycled or disposed of properly.

### 5.1.2 Removal and Disposal of Project Components

The removal and disposal details of the Project components are found below:

- **Panels:** Panels inspected for physical damage, tested for functionality, and removed from racking. Functioning panels packed and stored for reuse (functioning panels may produce power for another 25 years or more). Non-functioning panels packaged and sent to the manufacturer or a third party for recycling or another appropriate disposal method;
- **Racking:** Racking uninstalled, sorted, and sent to metal recycling facility;
- **Steel Pier Foundations:** Steel piles removed and sent to a recycling facility;
- **Wire:** belowground wire abandoned in place at depths greater than four feet. Wire above four feet removed and packaged for recycling or disposal;
- **Conduit:** Above-ground conduit disassembled onsite and sent to recycling facility;

- **Junction boxes, combiner boxes, external disconnect boxes, etc.:** Sent to electronics recycler;
- **Inverter/Transformer:** Evaluate remaining operation life and resell or send to manufacturer and/or electronics recycler;
- **Concrete pad(s):** Sent to concrete recycler;
- **Fence:** Fence will be sent to metal recycling facility and wooden posts for the agricultural fence will be properly disposed; and
- **Computers, monitors, hard drives, and other components:** Sent to electronics recycler. Functioning parts can be reused.

### 5.1.3 Restoration/Reclamation of Facility Site

After all equipment is removed, the facility could be restored to an agricultural use, in accordance with the AIMP or to another use if the economic conditions at that time indicate another use is an appropriate use for the site. Holes created by steel pier foundations and fence poles, concrete pads, re-claimed access road corridors and other equipment will be filled in with soil to existing conditions and seeded. Grading and other soil disturbance activities during decommissioning will be kept to the minimum necessary to effectively decommission the site to maintain the soil benefits realized during the long-term operation of the Project, such benefits include: building topsoil through plant matter decay, carbon capture, and beneficial, soil bacteria that are often absent from soil subject to rowcrop agriculture. This will include the revegetation.

Elk Creek Solar reserves the right to extend operations instead of decommissioning at the end of the site permit term. In this case, a decision may be made on whether to continue operation with existing equipment or to retrofit the facilities with upgrades based on newer technologies. If the decision is made to continue operations, the Project will be re-permitted.

## Figures



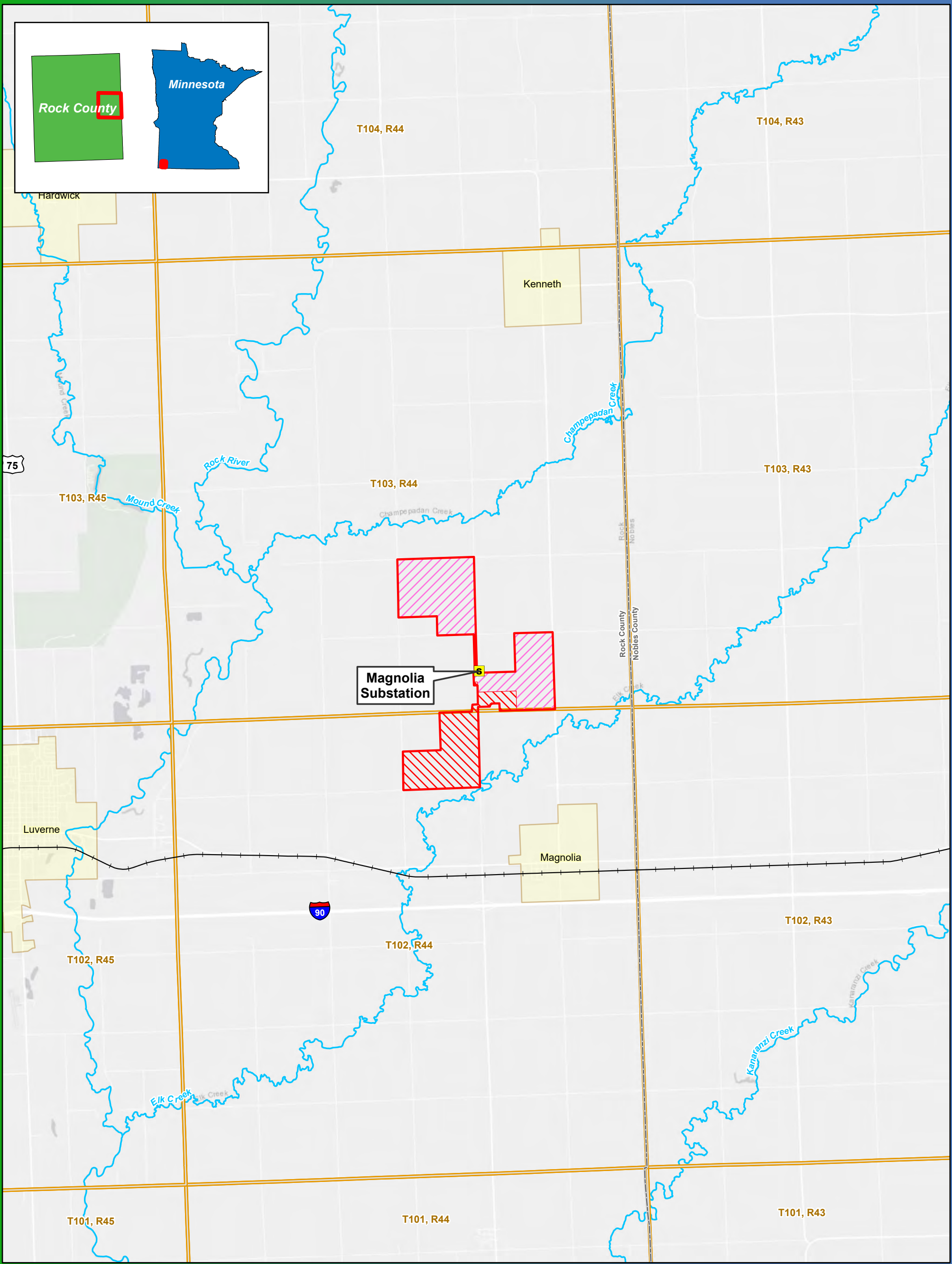

**Figure 1**  
**Project Location**  
**Elk Creek Solar Project**  
**Rock County, MN**  
**43.67819, -96.09293**



0 1 2 Miles

1:75,000

- Existing Substation
- 2023 Land Control Area
- Amended Land Control
- 2020 Land Control Area
- City/Town
- Township
- County Boundary
- NHD Named Stream
- Railroad

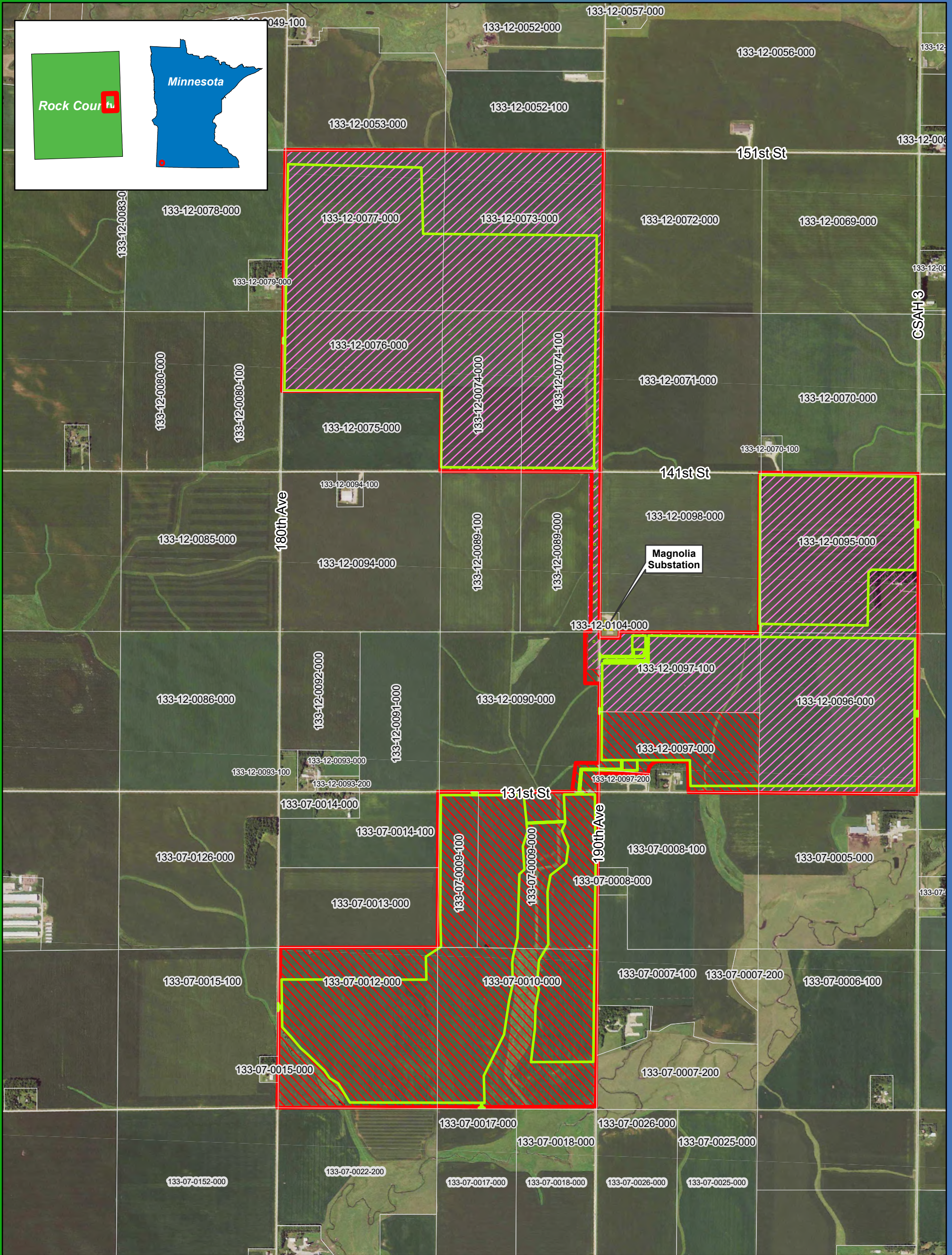
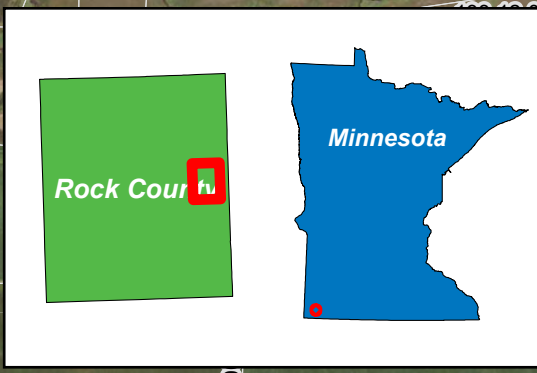

0 0.25 0.5 Miles



1:18,000

Data Source: National Grid Renewables,  
MN DOT, Rock County  
Imagery Source: 2021 FSA

**Figure 2**  
**2023 Land Control and**  
**Preliminary Development Areas**  
**Elk Creek Solar Project**  
**Rock County, MN**  
**43.67819, -96.09293**

- Existing Substation
- 2023 Land Control Area
- Amended Land Control
- 2020 Land Control Area
- 2023 Preliminary Development Area
- Parcel Boundary

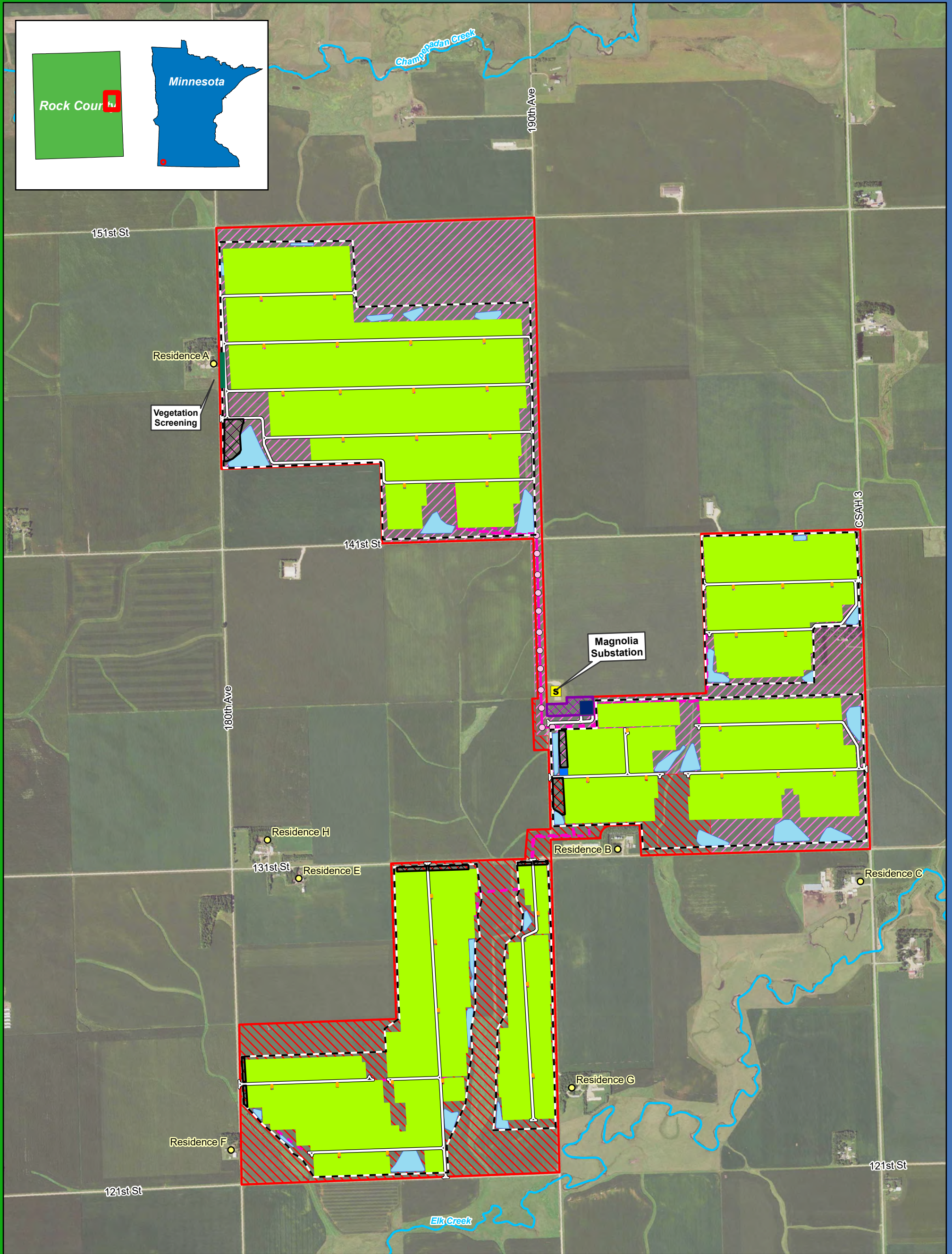
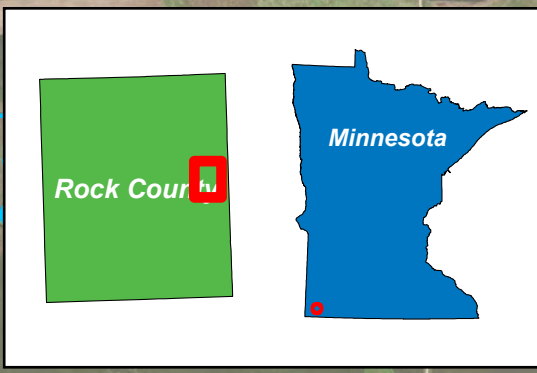

0 0.25 0.5 Miles

1:18,000

Data Source: National Grid Renewables, USGS, MN DOT  
Imagery Source: 2021 FSA

**Figure 3**  
**Preliminary Project Layout**  
**Elk Creek Solar Project**  
**Rock County, MN**  
**43.67819, -96.09293**

- |                               |                          |                         |
|-------------------------------|--------------------------|-------------------------|
| ○ Adjacent Residence          | ■ Vegetation Screening   | ■ Inverter              |
| ■ Existing Substation         | ■ 2023 Land Control Area | ■ Project Substation    |
| ○ Permanent Weather Stations  | ■ Amended Land Control   | ■ O&M Facility          |
| ○ Pole                        | ■ 2020 Land Control Area | ■ Associated Facilities |
| — Underground Collection Line | ■ Security Fence         | ■ Laydown Area          |
| — Overhead Collection Line    | ■ Access Road            | ■ NHD Stream            |
|                               | ■ Solar Array            | ■ Drainage Basin        |

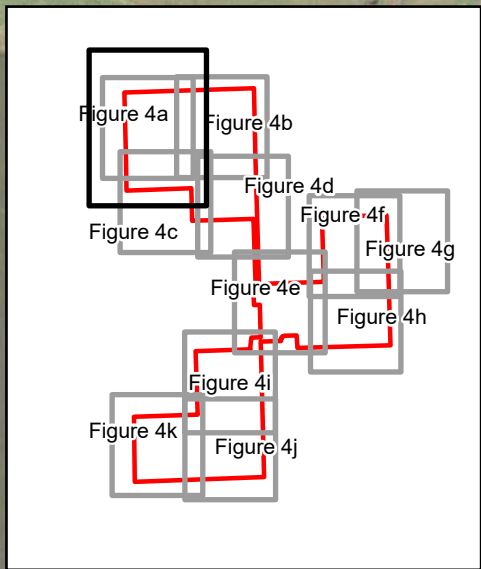

0 250 500 Feet  
1:5,500

Data Source: National Grid Renewables, USGS, MN DOT  
Imagery Source: 2021 FSA

**Figure 4a**  
**Preliminary Project Layout**  
**Elk Creek Solar Project**  
**Rock County, MN**  
**43.67819, -96.09293**

- |                               |                          |                         |
|-------------------------------|--------------------------|-------------------------|
| ○ Adjacent Residence          | — Vegetation Screening   | ▭ Inverter              |
| ■ Existing Substation         | ▨ 2020 Land Control Area | ▭ Project Substation    |
| ● Permanent Weather Stations  | ▨ Amended Land Control   | ▭ O&M Facility          |
| ○ Pole                        | ▭ 2023 Land Control Area | ▭ Associated Facilities |
| — Underground Collection Line | ▭ Security Fence         | ▭ Laydown Area          |
| — Overhead Collection Line    | ▭ Access Road            | ~ NHD Stream            |
|                               | ▭ Solar Array            | ~ Drainage Basin        |



Note: The configuration of the substation and O&M building is preliminary and subject to change with final engineering.



0 250 500 Feet  
1:5,500

Data Source: National Grid Renewables, USGS, MN DOT  
Imagery Source: 2021 FSA

**Figure 4b**  
**Preliminary Project Layout**  
**Elk Creek Solar Project**  
**Rock County, MN**  
**43.67819, -96.09293**

- |                                 |                          |                         |
|---------------------------------|--------------------------|-------------------------|
| ○ Adjacent Residence            | ■ Vegetation Screening   | ■ Inverter              |
| ■ Existing Substation           | ■ 2020 Land Control Area | ■ Project Substation    |
| ● Permanent Weather Stations    | ■ Amended Land Control   | ■ O&M Facility          |
| ○ Pole                          | ■ 2023 Land Control Area | ■ Associated Facilities |
| --- Underground Collection Line | ■ Security Fence         | ■ Laydown Area          |
| — Overhead Collection Line      | ■ Access Road            | ~ NHD Stream            |
|                                 | ■ Solar Array            | ■ Drainage Basin        |



Note: The configuration of the substation and O&M building is preliminary and subject to change with final engineering.



0 250 500 Feet  
1:5,500

Data Source: National Grid Renewables, USGS, MN DOT  
Imagery Source: 2021 FSA

**Figure 4c**  
**Preliminary Project Layout**  
**Elk Creek Solar Project**  
**Rock County, MN**  
**43.67819, -96.09293**

- |                               |                          |                         |
|-------------------------------|--------------------------|-------------------------|
| ○ Adjacent Residence          | — Vegetation Screening   | ▭ Inverter              |
| ■ Existing Substation         | ▨ 2020 Land Control Area | ▭ Project Substation    |
| ● Permanent Weather Stations  | ▨ Amended Land Control   | ▭ O&M Facility          |
| ○ Pole                        | ▭ 2023 Land Control Area | ▭ Associated Facilities |
| — Underground Collection Line | ▭ Security Fence         | ▭ Laydown Area          |
| — Overhead Collection Line    | ▭ Access Road            | ~ NHD Stream            |
|                               | ▭ Solar Array            | ~ Drainage Basin        |

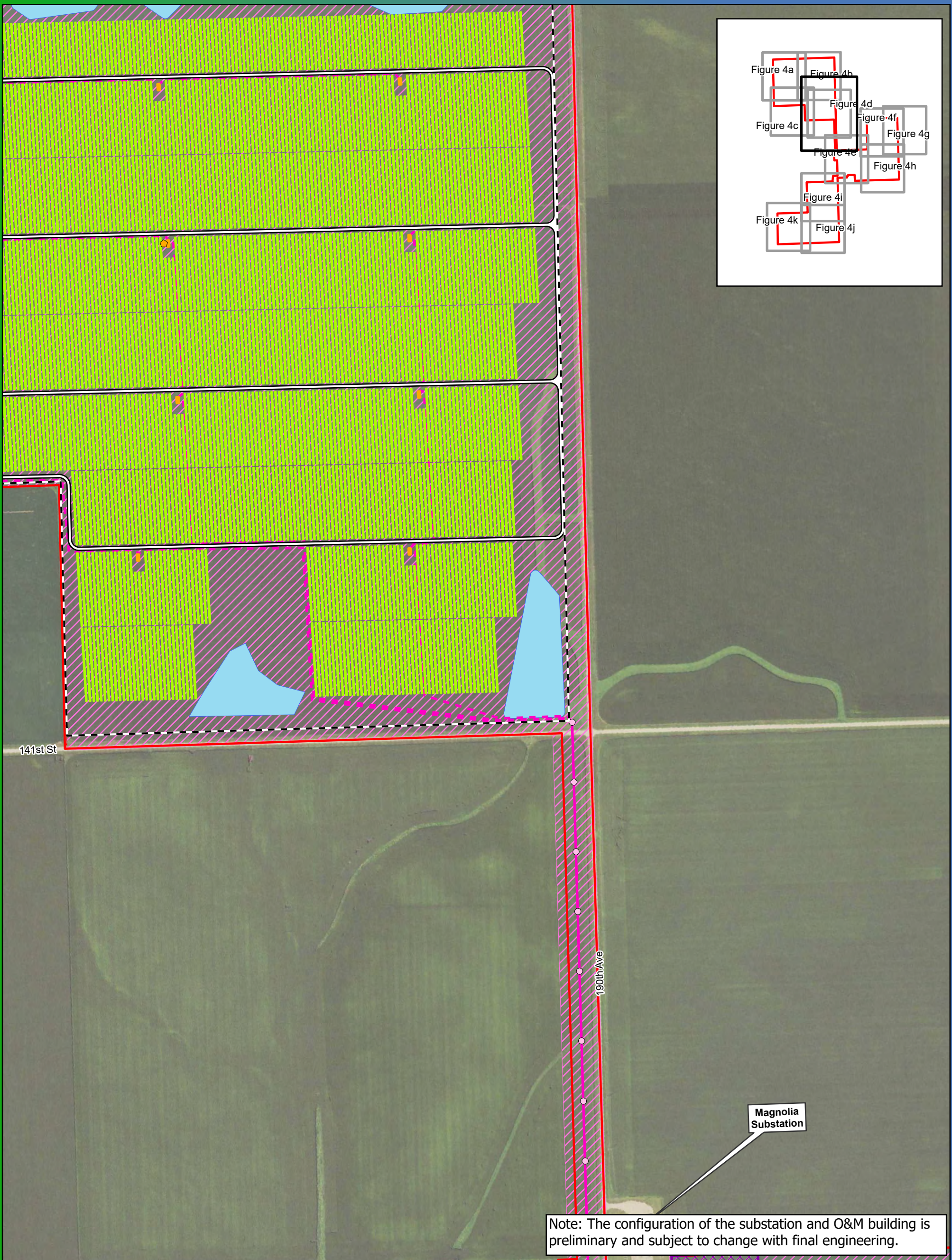

Note: The configuration of the substation and O&M building is preliminary and subject to change with final engineering.

**0 250 500 Feet**  
1:5,500

Data Source: National Grid Renewables, USGS, MN DOT  
Imagery Source: 2021 FSA

**Figure 4d**  
**Preliminary Project Layout**  
**Elk Creek Solar Project**  
**Rock County, MN**  
**43.67819, -96.09293**

○ Adjacent Residence	■ Vegetation Screening	■ Inverter
■ Existing Substation	■ 2020 Land Control Area	■ Project Substation
● Permanent Weather Stations	■ Amended Land Control	■ O&M Facility
○ Pole	■ 2023 Land Control Area	■ Associated Facilities
--- Underground Collection Line	■ Security Fence	■ Laydown Area
--- Overhead Collection Line	■ Access Road	~ NHD Stream
	■ Solar Array	■ Drainage Basin



Note: The configuration of the substation and O&M building is preliminary and subject to change with final engineering.



0 250 500 Feet  
1:5,500

Data Source: National Grid Renewables, USGS, MN DOT  
Imagery Source: 2021 FSA

**Figure 4e**  
**Preliminary Project Layout**  
**Elk Creek Solar Project**  
**Rock County, MN**  
**43.67819, -96.09293**

- |                                 |                          |                         |
|---------------------------------|--------------------------|-------------------------|
| ○ Adjacent Residence            | ■ Vegetation Screening   | ■ Inverter              |
| ■ Existing Substation           | ■ 2020 Land Control Area | ■ Project Substation    |
| ● Permanent Weather Stations    | ■ Amended Land Control   | ■ O&M Facility          |
| ○ Pole                          | ■ 2023 Land Control Area | ■ Associated Facilities |
| --- Underground Collection Line | ■ Security Fence         | ■ Laydown Area          |
| --- Overhead Collection Line    | ■ Access Road            | ■ NHD Stream            |
|                                 | ■ Solar Array            | ■ Drainage Basin        |



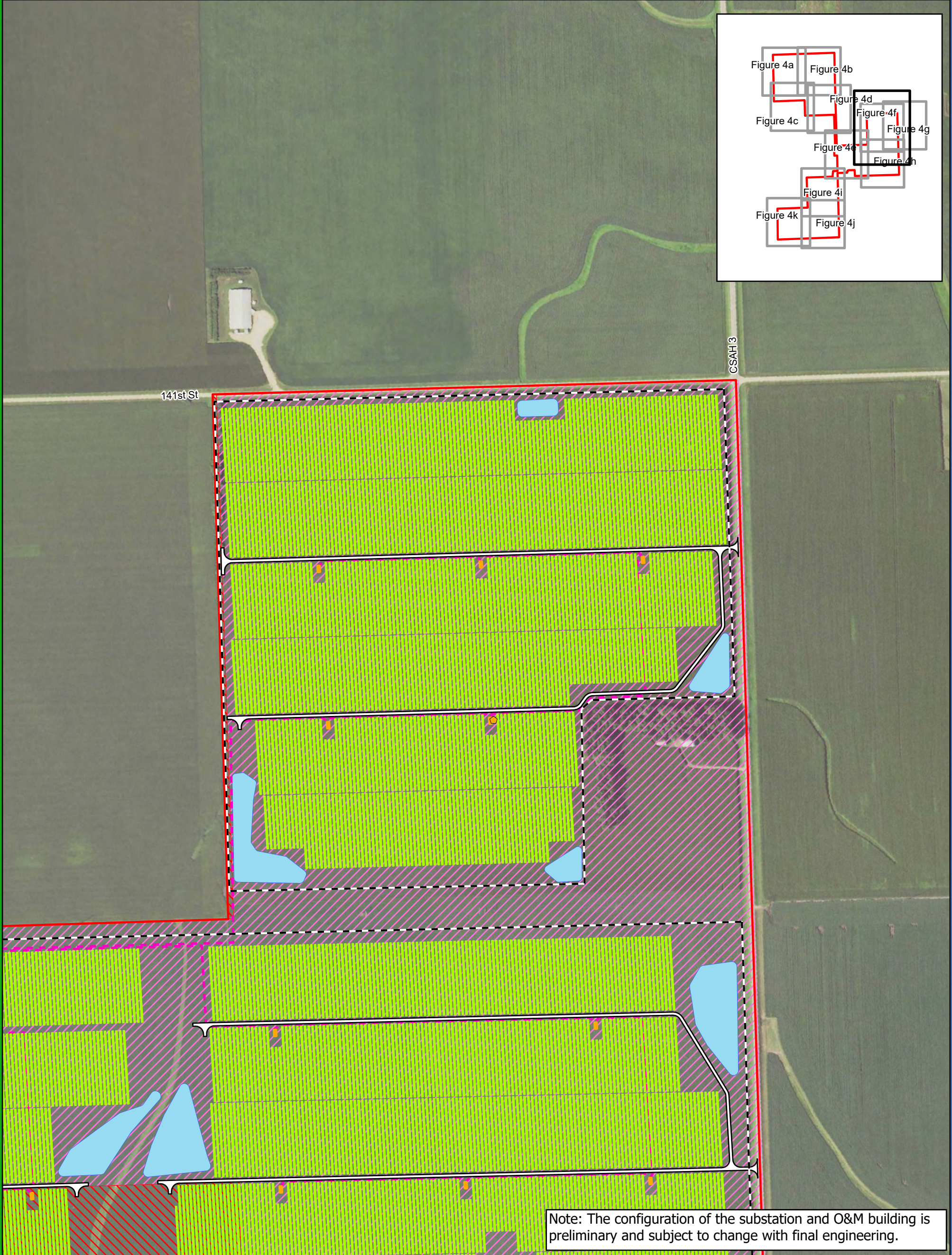
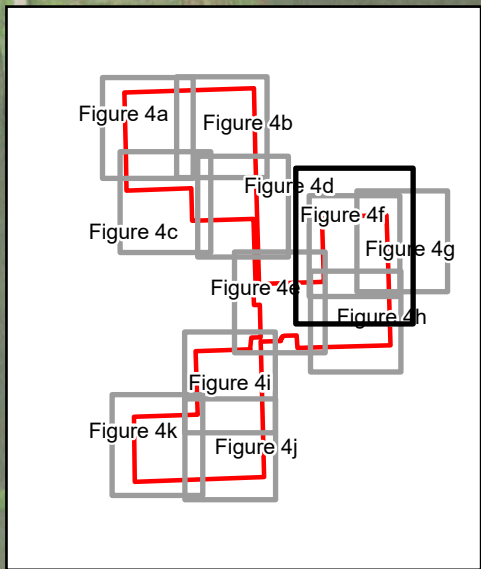

Note: The configuration of the substation and O&M building is preliminary and subject to change with final engineering.



0 250 500 Feet  
1:5,500

Data Source: National Grid Renewables, USGS, MN DOT  
Imagery Source: 2021 FSA

**Figure 4f**  
**Preliminary Project Layout**  
**Elk Creek Solar Project**  
**Rock County, MN**  
**43.67819, -96.09293**

- |                                 |                          |                         |
|---------------------------------|--------------------------|-------------------------|
| ○ Adjacent Residence            | ■ Vegetation Screening   | ■ Inverter              |
| ■ Existing Substation           | ■ 2020 Land Control Area | ■ Project Substation    |
| ● Permanent Weather Stations    | ■ Amended Land Control   | ■ O&M Facility          |
| ○ Pole                          | ■ 2023 Land Control Area | ■ Associated Facilities |
| --- Underground Collection Line | ■ Security Fence         | ■ Laydown Area          |
| --- Overhead Collection Line    | □ Access Road            | ~ NHD Stream            |
|                                 | ■ Solar Array            | ■ Drainage Basin        |

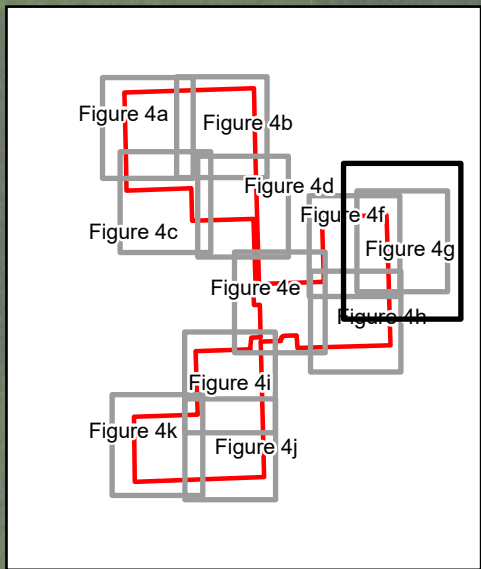

0 250 500 Feet  
1:5,500

Data Source: National Grid Renewables, USGS, MN DOT  
Imagery Source: 2021 FSA

**Figure 4g**  
**Preliminary Project Layout**  
**Elk Creek Solar Project**  
**Rock County, MN**  
**43.67819, -96.09293**

- |                                 |                          |                         |
|---------------------------------|--------------------------|-------------------------|
| ○ Adjacent Residence            | ■ Vegetation Screening   | ■ Inverter              |
| ■ Existing Substation           | ■ 2020 Land Control Area | ■ Project Substation    |
| ● Permanent Weather Stations    | ■ Amended Land Control   | ■ O&M Facility          |
| ○ Pole                          | ■ 2023 Land Control Area | ■ Associated Facilities |
| --- Underground Collection Line | ■ Security Fence         | ■ Laydown Area          |
| --- Overhead Collection Line    | ■ Access Road            | ~ NHD Stream            |
|                                 | ■ Solar Array            | ■ Drainage Basin        |

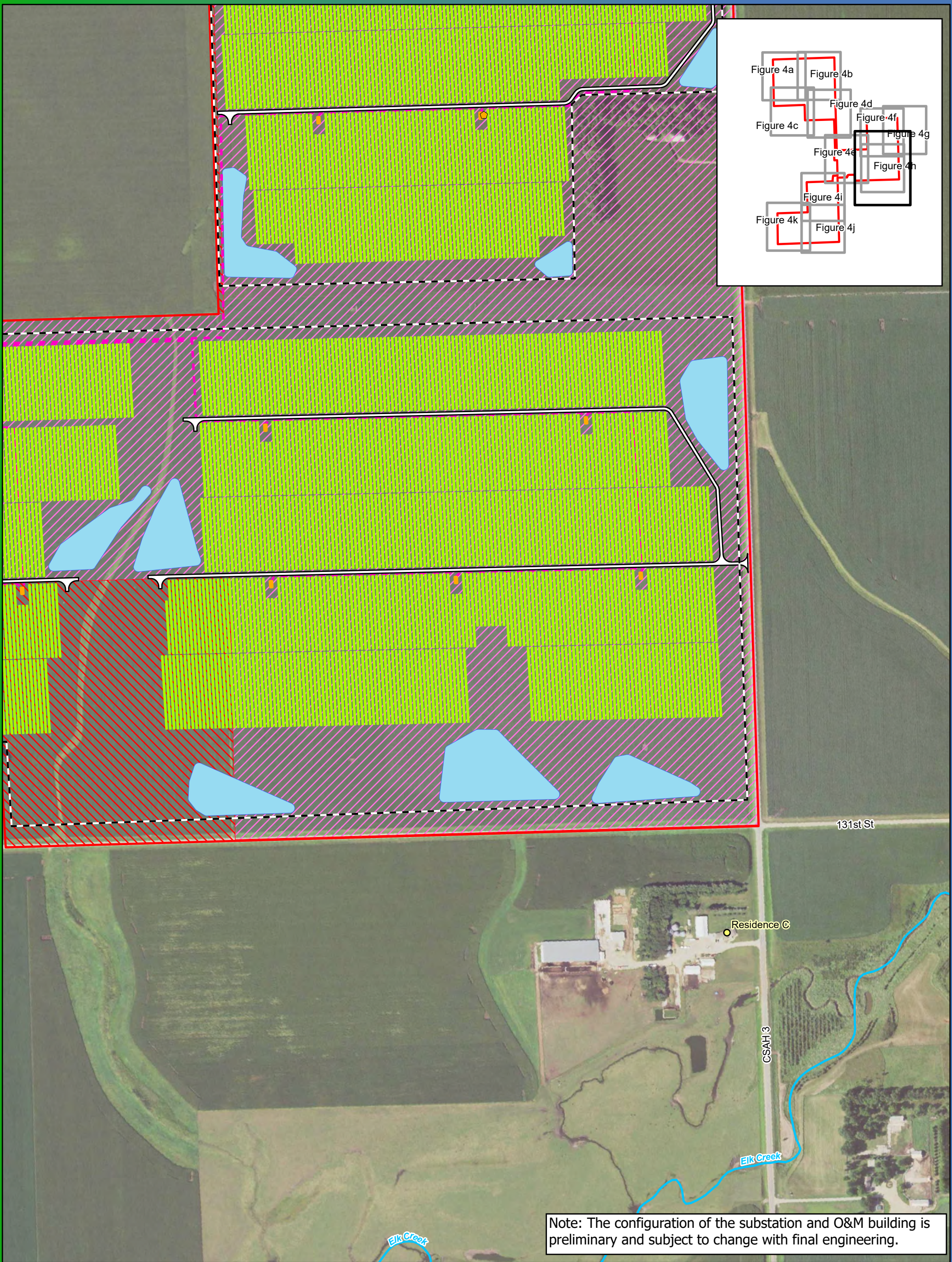

Note: The configuration of the substation and O&M building is preliminary and subject to change with final engineering.



0 250 500 Feet  
1:5,500

Data Source: National Grid Renewables, USGS, MN DOT  
Imagery Source: 2021 FSA

**Figure 4h**  
**Preliminary Project Layout**  
**Elk Creek Solar Project**  
**Rock County, MN**  
**43.67819, -96.09293**

- |                                   |                          |                         |
|-----------------------------------|--------------------------|-------------------------|
| ○ Adjacent Residence              | ■ Vegetation Screening   | ■ Inverter              |
| ■ Existing Substation             | ▨ 2020 Land Control Area | ■ Project Substation    |
| ● Permanent Weather Stations      | ▨ Amended Land Control   | ■ O&M Facility          |
| ○ Pole                            | ▨ 2023 Land Control Area | ■ Associated Facilities |
| - - - Underground Collection Line | ▨ Security Fence         | ■ Laydown Area          |
| — Overhead Collection Line        | □ Access Road            | ~ NHD Stream            |
|                                   | ■ Solar Array            | ☁ Drainage Basin        |